



Class TJ 230

Book 1564

Copyright N^o _____

COPYRIGHT DEPOSIT.

WORKS OF
PROFESSOR ALBERT W. SMITH

PUBLISHED BY

JOHN WILEY & SONS.

Machine Design.

By ALBERT W. SMITH, Director of Sibley College, Cornell University, and GUIDO H. MARX, Associate Professor of Mechanical Engineering, Leland Stanford Junior University. 8vo, viii + 369 pages, 278 figures. Cloth, \$3.00.

Materials of Machines.

By ALBERT W. SMITH, Director of Sibley College, Cornell University. 12mo, v + 142 pages, 17 figures. Cloth, \$1.00.

MACHINE DESIGN

BY

ALBERT W. SMITH

Director of Sibley College, Cornell University

AND

GUIDO H. MARX

*Associate Professor of Mechanical Engineering
Leland Stanford Junior University*

FIRST EDITION

FIRST THOUSAND

NEW YORK

JOHN WILEY & SONS

LONDON: CHAPMAN & HALL, LIMITED

1905

TJ 230
.S64

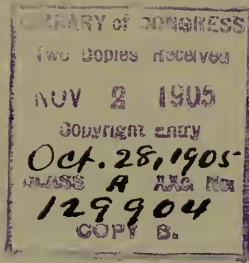

Copyright, 1905

BY

ALBERT W. SMITH AND GUIDO H. MARX



5-39887

INTRODUCTION.

IN general there are four considerations of prime importance in designing machines: I. Adaptation, II. Strength and Stiffness, III. Economy, IV. Appearance.

I. This requires all complexity to be reduced to its lowest terms in order that the machine shall accomplish the desired result in the most direct way possible, and with greatest convenience to the operator.

II. This requires the machine parts subjected to the action of forces to sustain these forces, not only without rupture, but also without such yielding as would interfere with the accurate action of the machine. In many cases the forces to be resisted may be calculated, and the laws of Mechanics and the known qualities of constructive materials become factors in determining proportions. In other cases the force, by the use of a "breaking-piece," may be limited to a maximum value, which therefore dictates the design. But in many other cases the forces acting are necessarily unknown; and appeal must be made to the precedent of successful practice, or to the judgment of some experienced man, until one's own judgment becomes trustworthy by experience.

In proportioning machine parts, the designer must always be sure that the stress which is the basis of the calculation or the estimate, is the maximum possible stress; otherwise the part will be incorrectly proportioned. For instance, if the arms of a pulley were to be designed solely on the assumption that they

endure only the transverse stress due to the belt tension, they would be found to be absurdly small, because the stresses resulting from the shrinkage of the casting in cooling are often far greater than those due to the belt pull.

The design of many machines is a result of what may be called "machine evolution." The first machine was built according to the best judgment of its designer; but that judgment was fallible, and some part yielded under the stresses sustained; it was replaced by a new part made stronger; it yielded again, and again was enlarged, or perhaps made of some more suitable material; it then sustained the applied stresses satisfactorily. Some other part yielded too much under stress, although it was entirely safe from actual rupture; this part was then stiffened and the process continued till the whole machine became properly proportioned for the resisting of stress. Many valuable lessons have been learned from this process; many excellent machines have resulted from it. There are, however, two objections to it: it is slow and very expensive, and if any part had originally an excess of material, it is not changed; only the parts that yield are perfected.

III. The attainment of economy does not necessarily mean the saving of metal or labor, although it may mean that. To illustrate: Suppose that it is required to design an engine-lathe for the market. The competition is sharp; the profits are small. How shall the designer change the design of the lathes on the market to increase profits? (*a*) He may, if possible, reduce the weight of metal used, maintaining strength and stiffness by better distribution. But this must not increase labor in the foundry or machine-shop, nor reduce weight which prevents undue vibrations. (*b*) He may design special tools to reduce labor without reduction of the standard of workmanship. The interest on the first cost of these special tools, however, must not exceed the possible gain from increased profits. (*c*) He may make the lathe more convenient for the workmen. True economy permits some increase

in cost to gain this end. It is not meant that elaborate and expensive devices are to be used, such as often come from men of more inventiveness than judgment; but that if the parts can be rearranged, or in any way changed so that the lathes-man shall select this lathe to use because it is handier, when other lathes are available, then economy has been served, even though the cost has been somewhat increased, because the favorable opinion of intelligent workmen means increased sales.

In (*a*) economy is served by a reduction of metal; in (*b*) by a reduction of labor; in (*c*) it may be served by an increase of both labor and material.

The addition of material largely in excess of that necessary for strength and rigidity, to reduce vibrations, may also be in the interest of economy, because it may increase the durability of the machine and its foundation; may reduce the expense incident upon repairs and delays, thereby bettering the reputation of the machine and increasing sales.

Suppose, to illustrate further, that a machine part is to be designed, and either of two forms, *A* or *B*, will serve equally well. The part is to be of cast iron. The pattern for *A* will cost twice as much as for *B*. In the foundry and machine-shop, however, *A* can be produced a very little cheaper than *B*. Clearly then if but one machine is to be built, *B* should be decided on; whereas, if the machine is to be manufactured in large numbers, *A* is preferable. Expense for patterns is a first cost. Expense for work in the foundry and machine-shop is repeated with each machine.

Economy of operation also needs attention. This depends upon the efficiency of the machine; *i.e.*, upon the proportion of the energy supplied to the machine which really does useful work. This efficiency is increased by the reduction of useless frictional resistances, by careful attention to the design and means of lubrication of rubbing surfaces.

In order that economy may be best attained, the machine designer needs to be familiar with all the processes used in the construction of machines—pattern-making, foundry work, forging, and the processes of the machine-shop—and must have them constantly in mind, so that while each part designed is made strong enough and stiff enough, and properly and conveniently arranged, and of such form as to be satisfactory in appearance, it also is so designed that the cost of construction is a minimum.

IV. The fourth important consideration is Appearance. There is a *beauty* possible of attainment in the design of machines which is always the outgrowth of a *purpose*. Otherwise expressed, a machine to be *beautiful* must be *purposeful*. Ornament for ornament's sake is seldom admissible in machine design. And yet the striving for a pleasing effect is as much a part of the duty of a machine designer as it is a part of the duty of an architect.

CONTENTS.

CHAPTER I.

	PAGE
PRELIMINARY	I

CHAPTER II.

MOTION IN MECHANISMS.....	14
---------------------------	----

CHAPTER III.

PARALLEL OR STRAIGHT-LINE MOTIONS.....	39
--	----

CHAPTER IV.

CAMS.....	44
-----------	----

CHAPTER V.

ENERGY IN MACHINES.....	50
-------------------------	----

CHAPTER VI.

PROPORTIONS OF MACHINE PARTS AS DICTATED BY STRESS.....	67
---	----

CHAPTER VII.

RIVETED JOINTS.....	83
---------------------	----

CHAPTER VIII.

BOLTS AND SCREWS.....	112
-----------------------	-----

CHAPTER IX.

MEANS FOR PREVENTING RELATIVE ROTATION.....	141
---	-----

	PAGE
CHAPTER X.	
SLIDING SURFACES.....	153
CHAPTER XI.	
AXLES, SHAFTS, AND SPINDLES.....	161
CHAPTER XII.	
JOURNALS, BEARINGS, AND LUBRICATION.....	172
CHAPTER XIII.	
ROLLER- AND BALL-BEARINGS.....	198
CHAPTER XIV.	
COUPLINGS AND CLUTCHES.....	209
CHAPTER XV.	
BELTS.....	218
CHAPTER XVI.	
FLY-WHEELS.....	244
CHAPTER XVII.	
TOOTHED WHEELS OR GEARS.....	261
CHAPTER XVIII.	
SPRINGS.....	308
CHAPTER XIX.	
MACHINE SUPPORTS.....	313
CHAPTER XX.	
MACHINE FRAMES.....	318
APPENDIX.....	353
INDEX.....	361

MACHINE DESIGN.

CHAPTER I.

PRELIMINARY.

1. **Definitions.**—The study of machine design is based upon the science of mechanics, which treats questions involving the consideration of *motion*, *force*, *work*, and *energy*. Since it will be necessary to use these terms almost continually, it is well to make an exact statement of what is to be understood by them.

Motion may be defined as change of position in space.

A Force is one of a pair of equal, opposite, and simultaneous actions between two bodies by which the state of their motion is altered, or a change in the form or condition of the bodies themselves is effected.

Work is the name given to the result of a force in motion.

Energy is the capacity possessed by matter to do work.

The law of **Conservation of Energy** underlies every machine problem. This law may be expressed as follows: The sum of energy in the universe is constant. Energy may be transferred in space; it may be stored for varying lengths of time; it may be changed from one of its several forms to another; but it cannot be created or destroyed.

The application of this law to machines is as follows: A machine receives energy from a source, and uses it to do useful and useless work.

A complete cycle of action of a machine is such an interval that all conditions in the machine are the same at its beginning and end, each member of the machine having in the mean time gone through all motions possible to it.

During a complete cycle of action of the machine, the energy received equals the total work done. The work done may appear as (a) useful work delivered by the machine, or as (b) heat due to energy transformed through frictional resistance, or as (c) stored mechanical energy in some moving part of the machine whose velocity is increased. The sign of the stored energy may be plus or minus, so that energy received in one cycle may be delivered during another cycle; but for any considerable time interval of machine action the algebraic sum of the stored energy must equal zero.

For a single cycle:

Energy received = useful work + useless work \pm stored energy.

For continuous action:

Energy received = useful work + useless work.

In operation a machine generally acts by a continuous repetition of its cycle.

2. Efficiency of Machines.—In general, efficiency may be defined as the ratio of a *result* to the *effort* made to produce that result. In a machine the result corresponds to the useful work, while the effort corresponds to the energy received. Hence the efficiency of a machine = useful work \div energy received.* The designer must strive for high efficiency, *i.e.*, for the greatest possible result for a given effort.

3. Function of Machines.—Nature furnishes sources of *energy*, and the supplying of human needs requires *work* to be done. **The function of machines is to cause matter possessing energy to do useful work.**

* The work and energy must, of course, be expressed in the same units.

The *chief sources of energy in nature* available for machine purposes are:

1st. The energy of air in motion (*i.e.*, wind) due to its mass and velocity.

2d. The energy of water due to its mass and motion or position.

3d. The energy dormant in fuels which manifests itself as heat upon combustion.

The general method by which the machine function is exercised may be shown by the following illustration:

Illustration.—The water in a mill-pond possesses energy (potential) by virtue of its position. The earth exerts an attractive force upon it. If there is no outlet, the earth's attractive force cannot cause motion; and hence, since motion is a necessary factor of work, no work is done.

If the water overflows the dam, the earth's attraction causes that part of it which overflows to *move* to a lower level, and before it can be brought to rest again it does work against the force which brings it to rest. If this water simply falls upon rocks, its energy is transformed into heat, with no useful result.

But if the water is led from the pond to a lower level, in a closed pipe which connects with a water-wheel, it will act upon the vanes of the wheel (because of the earth's attraction), and will cause the wheel and its shaft to rotate against resistance, whereby it may do useful work. The water-wheel is a **machine** and is called a **Prime Mover**, because it is the first link in the machine-chain between natural energy and useful work.

Since it is usually necessary to do the required work at some distance from the necessary location of the water-wheel, **Machinery of Transmission** is used (shafts, pulleys, belts, cables, etc.), and the rotative energy is rendered available at the required place.

But this rotative energy may not be suitable to do the required work; the rotation may be too slow or too fast; a resist-

ance may need to be overcome in straight, parallel lines, or at periodical intervals. Hence **Machinery of Application** is introduced to transform the energy to meet the requirements of the work to be done. Thus the chain is complete, and the potential energy of the water does the required useful work.

The chain of machines which has the steam-boiler and engine for its prime mover transforms the potential heat energy of fuel into useful work. This might be analyzed in a similar way.

4. Free Motion.—The general science of mechanics treats of the action of forces upon “free bodies.”

In the case of a “free body” acted on by a system of forces not in equilibrium, motion results in the direction of the resultant of the system. If another force is introduced whose line of action does not coincide with that of the resultant, the line of action of the resultant is changed, and the body moves in a new direction. The character of the motion, therefore, is dependent upon the forces which produce the motion. This is called **free motion**.

Example.—In Fig. 1, suppose the free body M to be acted on by the concurrent forces 1, 2, and 3 whose lines of action pass through the center of gravity of M . The line of action of the resultant of these forces is AB , and the body's center of gravity would move along this line.

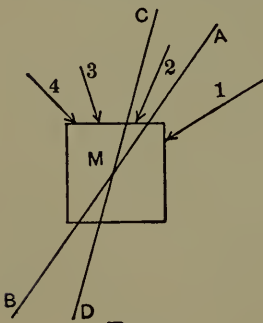

FIG. 1.

If another force, 4, is introduced, CD becomes the line of action of the resultant, and the motion of the body is along the line CD .

5. Constrained Motion.—In a machine certain definite motions occur; any departure from these motions, or the production of any other motions, would result in derangement of the action of the machine. Thus, the spindle of an engine-lathe turns accurately about its axis; the cutting-tool moves

parallel to the spindle's axis; and an accurate cylindrical surface is thereby produced. If there were any departure from these motions, the lathe would fail to do its required work. In all machines certain definite motions must be produced, and all other motions must be prevented; or, in other words, motion in machines must be *constrained*.

Constrained motion differs from free motion in being independent of the forces which produce it. If any force, not sufficiently great to produce deformation, be applied to a body whose motion is constrained, the result is either a certain predetermined motion, or no motion at all.

6. Force Opposed by Passive Resistance.—A force may act without being able to produce motion (and hence without being able to do work), as in the case of the water in a mill-pond without overflow or outlet. This may be further illustrated: Suppose a force, say hand pressure, to be applied vertically to the top of a table. The material of the table offers a *passive resistance*, and the force is unable to produce motion, or to do work.

It is therefore possible to offer passive resistance to such forces as may be required not to produce motion, thereby rendering them incapable of doing work. Whenever a body opposes a *passive resistance* to the action of a force a change in its condition is effected: the force sets up an equivalent *stress* in the material of the body. Thus, when the table offers a passive resistance to the hand-pressure, compressive stress is induced in the legs. In every case the material of the body must be of such shape and strength as to resist successfully the induced stress.

In a machine there must be provision for resisting every possible force which tends to produce any but the required motion. This provision is usually made by means of the *passive resistance* of properly formed and sufficiently resistant metallic surfaces.

Illustration I.—Fig. 2 represents a section and end view of

a wood-lathe headstock. It is required that the spindle, S , and the attached cone pulley, C , shall have no other motion than

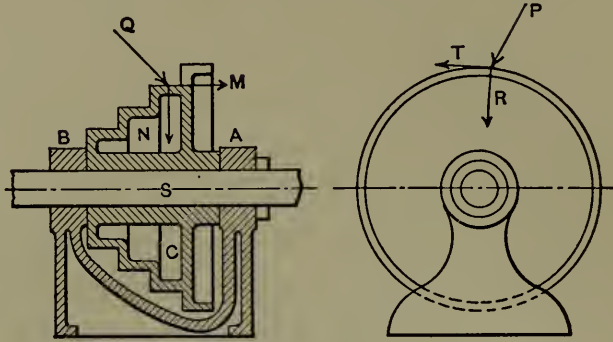

FIG. 2.

rotation about the axis of the spindle. If any other motion is possible, this machine part cannot be used for the required purpose. At A and B the cylindrical surfaces of the spindle are enclosed by accurately fitted bearings or internal cylindrical surfaces. Suppose any force, P , whose line of action lies in the plane of the paper, to be applied to the cone pulley. It may be resolved into a radial component, R , and a tangential component, T . The passive resistance of the cylindrical surfaces of the journal and its bearing, prevents R from producing motion; while it offers no resistance, friction being disregarded, to the action of T , which is allowed to produce the required motion, *i.e.*, rotation about the spindle's axis. If the line of action of P pass through the axis, its tangential component becomes zero, and no motion results. If the line of action of P become tangential, its radial component becomes zero, and P is wholly applied to produce rotation. If a force Q , whose line of action lies in the plane of the paper, be applied to the cone, it may be resolved into a radial component, N , and a component, M , parallel to the spindle's axis. N is resisted as before by the journal and bearing surfaces, and M is resisted by the shoulder surfaces of the bearings, which fit against the shoulder surfaces of the cone pulley. The force Q can therefore produce no motion at all.

In general, any force applied to the cone pulley may be resolved into a radial, a tangential, and an axial component. Of these only the tangential component is able to produce motion; and that motion is the motion required. The constraint is therefore complete; *i.e.*, there can be no motion except rotation about the spindle's axis. This result is due to the passive resistance of metallic surfaces.

Illustration II.—*R*, Fig. 3, represents, with all details omitted, the “ram,” or portion of a shaping-machine which carries the

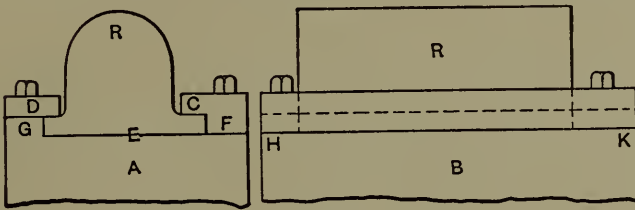

FIG. 3.

cutting-tool. It is required to produce plane surfaces, and hence the “ram” must have accurate rectilinear motion in the direction of *HK*. Any deviation from such motion would render the machine useless.

Consider Fig. 3, *A*. Any force which can be applied to the ram may be resolved into three components: one vertical, one horizontal and parallel to the paper, and one perpendicular to the paper. The vertical component, if acting upward, is resisted by the plane surfaces in contact at *C* and *D*; if acting downward, it is resisted by the plane surfaces in contact at *E*. Therefore no vertical component can produce motion. The horizontal component parallel to the paper is resisted by the plane surfaces in contact at *F* or *G*, according as it acts toward the right or left. The component perpendicular to the paper is free to produce motion in the direction of its line of action; but this is the motion required.

Any force, therefore, which has a component perpendicular to the paper can produce the required motion, but no other

motion. The constraint is therefore complete, and the result is due to the passive resistance offered by metallic surfaces.

Complete Constraint is not always required in machines. It is only necessary to prevent such motions as interfere with the accomplishment of the desired result.

The **weight** of a moving part is sometimes utilized to produce constraint in one direction. Thus in a planer-table, and in some lathe-carriages, downward motion and unallowable side motion are resisted by metallic surfaces; while upward motion is resisted by the weight of the moving part.

From the foregoing it follows that, as passive resistances can be opposed to all forces whose lines of action do not coincide with the desired direction of motion of any machine part, it may be said that the nature of the motion is independent of the forces producing it.

Since the motions of machine parts are independent of the forces producing them, it follows that the relation of such motions may be determined without bringing force into the consideration.

7. Kinds of Motion in Machines.—Motion in machines may be very complex, but it is chiefly **plane motion**.

When a body moves in such a way that any section of it remains in the same plane, its motion is called plane motion. All sections parallel to the above section must also remain, each in its own plane. If the plane motion is such that all points of the moving body remain at a constant distance from some line, *AB*, the motion is called **rotation** about the axis *AB*. *Example.*—A line-shaft with attached parts.

If all points of a body move in straight parallel paths, the motion of the body is called **rectilinear translation**. *Examples.*—Engine cross-head, lathe-carriage, planer-table, shaper-ram. Rectilinear translation may be conveniently considered as a special case of rotation, in which the axis of rotation is at an infinite distance, at right angles to the motion.

If a body moves parallel to an axis about which it rotates, the body is said to have **helical** or **screw motion**. *Example*.—A nut turning upon a stationary screw.

If all points of a body, whose motion is not plane motion, move so that their distances from a certain point, O , remain constant, the motion is called *spheric motion*. This is because each point moves in the surface of a sphere whose center is O . *Example*.—The arms of a fly-ball steam-engine governor, when the vertical position is changing.

8. Relative Motion.—The motion of any machine part, like all known motion, is relative motion. It is studied by reference to some other part of the same machine. Some one part of a machine is usually (though not necessarily) fixed, *i.e.*, it has no motion relative to the earth. This fixed part is called the **frame** of the machine. The motion of a machine part may be referred to the frame, or, as is often necessary, to some other part which also has motion relative to the frame.

The kind and amount of relative motion of a machine part depend upon the motions of the part to which its motion is referred.

Illustration.—Fig. 4 shows a press. A is the frame; C is a plate which is so constrained that, its motion being referred to A , it may move vertically, but cannot rotate. Motion of rotation is communicated to the screw B . The motion of B referred to A is helical motion, *i.e.*, combined rotation and translation. C , however, shares the translation of B , and hence there is left only rotation as the relative motion of B and C . The motion of B referred to C is rotation. The motion of C referred to B is rotation. The motion of C referred to A is translation.

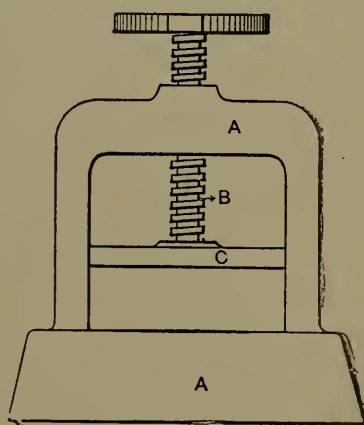

FIG. 4.

In general, if two machine members, M and N , move relative to a third member, R , the relative motion of M referred to N depends on how much of the motion of N is shared by M . If M and N have the same motions relative to R , they have no motion relative to each other.

Conversely, if two bodies have no relative motion, they have the same motion relative to a third body. Thus in Fig. 4, if the constraint of C were such that it could share B 's rotation, as well as its translation, then C would have helical motion relative to the frame, and no motion at all relative to B . This is assumed to be self-evident.

A **rigid body** is one in which the distance between elementary portions is constant. No body is absolutely rigid, but usually in machine members the departure from rigidity is so slight that it may be neglected.

Many machine members, as springs, etc., are useful because of their lack of rigidity.

Points in a rigid body can have no relative motion, and hence *must all have the same motion*.

9. Instantaneous Motion and Instantaneous Centers or Centers.—Points of a moving body trace more or less complex paths.

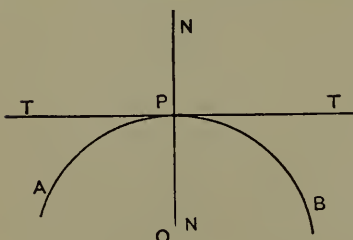

FIG. 5.

If a point be considered as moving from one position in its path to another indefinitely near, its motion is called **instantaneous motion**. The point is moving, for the instant, along a straight line joining the two indefinitely near together positions, and such a line is

a tangent to the path. In problems which are solved by the aid of the conception of instantaneous motion it is only necessary to know the *direction* of motion; hence, for such purposes, *the instantaneous motion of a point is fully defined by a tangent to its path through the point*.

Thus in Fig. 5, if a point is moving in the path APB , when it occupies the position P the tangent TT represents its instantaneous motion. Any number of curves could be drawn tangent to TT at P , and any one of them would be a possible path of the point; but whatever path it is following, its *instantaneous motion* is represented by TT . The instantaneous motion of a point is therefore independent of the *form* of its path. Any one of the possible paths may be considered as equivalent, for the instant, to a circle whose center is anywhere in the normal NN .

In general, the instantaneous motion of a point, P , is equivalent to rotation about some point, O , in a line through the point P perpendicular to the direction of its instantaneous motion.

Let the instantaneous motion of a point, A , Fig. 6, in a section of a moving body be given by the line TT . Then the motion is equivalent to rotation about some point on the line AB as a center, but it may be any point, and hence the instantaneous motion of the *body* is not determined. But if the instantaneous motion of another point, C , be given by the line T_1T_1 , this motion is equivalent to rotation about some point of CD . But the points A and C are points in a rigid body, and can have no relative motion, and must have the same motion, *i.e.*, rotation about the same center. A rotates about some point of AB , and C rotates about some point of CD ; but they must rotate about the same point, and the only point which is at the same time in both lines is their intersection, O . Hence A and C , and all other points of the body, rotate, for the instant, about an axis of which O is the projection; or, in other words, the instantaneous motion of the body is rotation about an axis of which O is the projection. This axis is the *instantaneous axis* of

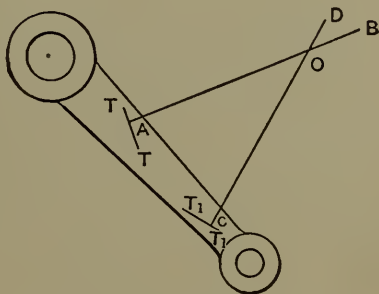

FIG. 6.

the body's motion, and O is the instantaneous center of the motion of the section shown in Fig. 6.

For the sake of brevity an instantaneous center will be called a **centro**.

If TT and T_1T_1 had been parallel to each other, AB and CD would also have been parallel, and would have intersected at infinity; in which case the body's instantaneous motion would have been rotation about an axis infinitely distant; *i.e.*, it would have been *translation*.

The motion of the body in Fig. 6 is of course referred to a fixed body, which, in this case, may be represented by the paper. The instantaneous motion of the body relative to the paper is rotation about O . Let M represent the figure, and N the fixed body represented by the paper. Suppose the material of M to be extended so as to include O . Then a pin could be put through O , materially connecting M and N , without interfering with their instantaneous motion. Such connection at any other point would interfere with the instantaneous motion.

The centro of the relative motion of two bodies is a point, and the only one, at which they have no relative motion; it is a point, and the only one, that is common to the two bodies for the instant.

It will be seen that the points of the figure in Fig. 6 might be moving in any paths, so long as those paths are tangent at the points to the lines representing the instantaneous motion.

In general, centros of the relative motion of two bodies are continually changing their position. They may, however, remain stationary; *i.e.*, they may become fixed centers of rotation.

10. Loci of Centros, or Centrodes.—As centros change position they describe curves of some kind, and these loci of centros may be called *centrodes*.

Suppose a section of any body, M , to have motion relatively to a section of another body, N (fixed), in the same or a parallel plane. Centros may be found for a series of positions, and a

curve drawn through them on the plane of N would be the centre of the motion of M relatively to N . If, now, M being fixed, N moves so that the relative motion is the same as before, the centre of the motion of N relatively to M may be located upon the plane of M . Now, since the centre of the relative motion of two bodies is a point at which they have no relative motion, and since the points of the centres become successively the centres of the relative motion, it follows that as the motion goes on, the centres would roll upon each other without slipping. Therefore, if the centres are drawn, and rolled upon each other without slipping, the bodies M and N will have the same relative motion as before. From this it follows that the relative plane motion of two bodies may be reproduced by rolling together, without slipping, the centres of that motion.

II. Pairs of Motion Elements.—The external and internal surfaces by which motion is constrained, as in Figs. 2 and 3, may be called **pairs of motion elements**. The pair in Fig. 2 is called a **turning pair**, and the pair in Fig. 3 is called a **sliding pair**.

The helical surfaces by which a nut and screw engage with each other are called a **twisting pair**. These three pairs of motion elements have their surfaces in contact throughout. They are called **lower pairs**. Another class, called **higher pairs**, have contact only along elements of their surfaces. *Examples.*—Cams and toothed wheels.

CHAPTER II.

MOTION IN MECHANISMS.

12. Linkages or Motion Chains; Mechanisms.

In Fig. 7, b is joined to c by a turning pair;

c	“	d	“	sliding	“
d	“	a	“	turning	“
a	“	b	“	“	“

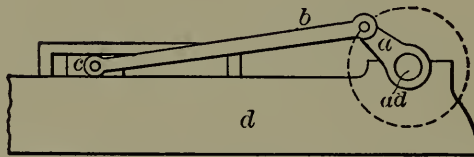

FIG. 7.

Evidently there is complete constraint of the relative motion of a , b , c , and d . For, d being fixed, if any motion occurs in either a , b , or c , the other two must have a predetermined corresponding motion.

c may represent the cross-head, b the connecting-rod, and a the crank of a steam-engine of the ordinary type. If c were rigidly attached to a piston upon which the expansive force of steam acts toward the right, a must rotate about ad . This represents a *machine*. The members a , b , c , and d may be represented for the study of relative motions by the diagram, Fig. 8.

This assemblage of bodies, connected so that there is complete constraint of motion, may be called a **motion chain** or **linkage**, and the connected bodies may be called **links**. The chain shown is a **simple chain**, because no link is joined to more than two others. If any links of a chain are joined to more than two

others, the chain is a **compound chain**. Examples will be given later.

When one link of a chain is fixed, *i.e.*, when it becomes the standard to which the motion of the others is referred, the chain is called a **mechanism**. Fixing different links of a chain gives different mechanisms. Thus in Fig. 8, if d is fixed, the mechanism is that which is used in the usual type of steam-engine, as in Fig. 7. It is called the **slider-crank mechanism**.

But if a is fixed, the result is an entirely different mechanism; for b would then rotate about the permanent center ab , d would rotate about the permanent center ad , while c would have a more complex motion, rotating about a constantly changing centro, whose path may be found.

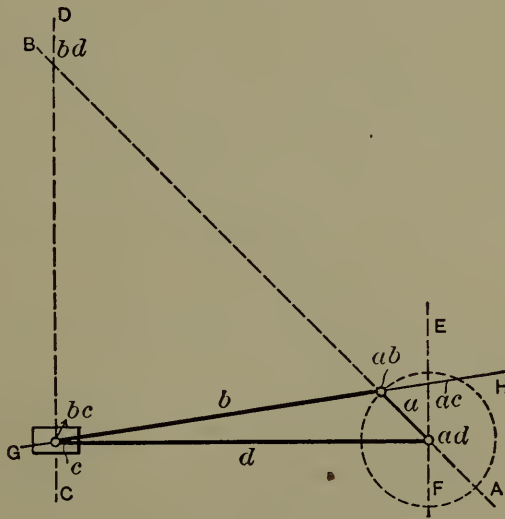

FIG. 8.

Fixing b or c would give, in each case, a still different mechanism.

13. Location of Centros.—In Fig. 8 d is fixed and it is required to find the centers of rotation, either permanent or instantaneous, of the other three links. The motion of a , relative to the fixed link d , is rotation about the fixed center ad . The motion of c relative to d is translation, or rotation about a centro

cd , at infinity vertically. The link b has a point in common with a ; it is the centro, ab , of their relative motion. This point may be considered as a point in a or b ; in either case it can have but one direction of motion relative to any one standard. As a point in a its motion, relative to d , is rotation about ad . For the instant, then, it is moving along a tangent to the circle through ab . But, as a point in b , its direction of instantaneous motion relative to d must be the same, and hence its motion must be rotation about some point in the line $ad-ab$, extended if necessary. Also, b has a point, bc , in common with c ; and by the same reasoning as above, bc , as a point in b , rotates for the instant about some point of the vertical line through bc . Now ab and bc are points of a rigid body, and one rotates for the instant about some point of AB , and the other rotates for the instant about some point of CD ; hence both ab and bc (as well as all other points of b) must rotate about the intersection of AB and CD . Hence bd is the centro of the motion of B relative to d .

The motion of a may be referred to c (fixed), and ac will be found (by reasoning like that applied to b) to lie at the intersection of the lines EF and GH .

The motion chain in Fig. 8, as before stated, is called the **slider-crank chain**.

14. Centros of the Relative Motion of Three Bodies are always in the Same Straight Line.—In Fig. 8 it will be seen that the three centros of any three links lie in the same straight line. Thus ad , ab , and bd are the centros of the links a , b , and d . This is true of any other set of three links.

Proof.—Consider a , b , and d . The centro ab as a point in a has a direction of instantaneous motion relative to d perpendicular to a line joining it to ad . As a point in b it has a direction of instantaneous motion relative to d perpendicular to a line joining it to bd . Therefore the lines $ab-ad$ and $ab-bd$ are both perpendicular to the direction of instantaneous motion of ab , and

they also both pass through ab ; hence they must coincide, and therefore ab , ad , and bd must lie in the same straight line. But a , b , and d might be any three bodies whatever which have relative plane motion, and the above reasoning would hold. Hence it may be stated: *The three centros of any three bodies having relative plane motion must lie in the same straight line.* (The statement and proof of this important proposition is due to Prof. Kennedy.)

15. **Lever-crank Chain. Location of Centros.**—Fig. 9 shows a chain of four links of unequal length joined to each other by

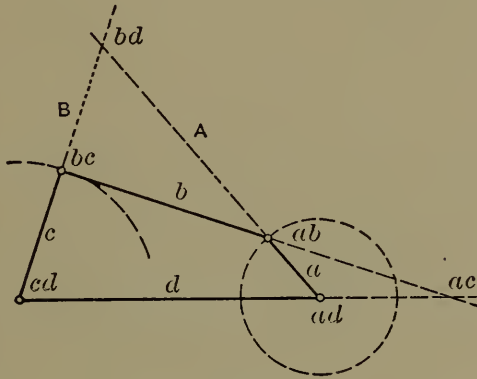

FIG. 9.

turning pairs. The centros ab , ad , cd , and bc may be located at once, since they are at the centers of turning pairs which join adjacent links to each other. The centros of the relative motion of b , c , and d are bc , cd , and bd , and these must be in the same straight line. Hence bd is in the line B . The centros of the relative motion of a , b , and d are ab , bd , and ad ; and these also must lie in a straight line. Hence bd is in the line A . Being at the same time in A and B , it must be at their intersection. By employing the same method ac may be found.

16. **The Constraint of Motion** in a linkage is **independent of the size of the motion elements.** As long as the cylindrical surfaces of turning pairs have their axes unchanged, the surfaces themselves may be of any size whatever, and the motion is unchanged. The same is true of sliding and twisting pairs.

In Fig. 10, suppose the turning pair connecting c and d to be enlarged so that it includes bc . The link c now becomes a

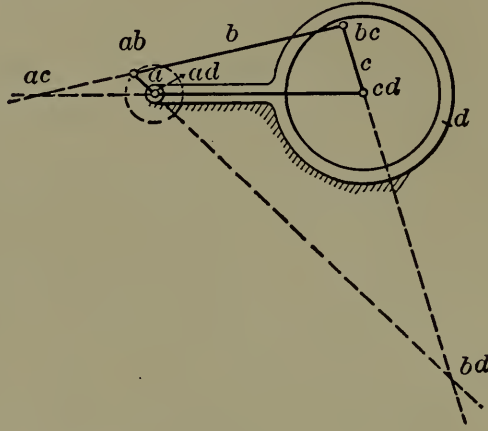

FIG. 10.

cylinder, turning in a ring attached to, and forming part of, the link d . bc becomes a pin made fast in c and engaging with an eye at the end of b . The centros are the same as before the enlargement of the pair cd , and hence the relative motion is the same.

In Fig. 11 the circular portion immediately surrounding cd is attached to d . The link c now becomes a ring moving in a circular slot. This may be simplified as in Fig. 12, whence c becomes a curved block moving in a limited circular slot in d . The centros remain as before, the relative motion is the same, and the linkage is essentially unchanged.

If, in the slider-crank mechanism, the turning pair whose axis is ab be enlarged till ad is included, as in Fig. 13, the motion of the mechanism is unchanged, but the link a is now called an eccentric instead of a crank. This mechanism is usually used to communicate motion from the main shaft of a steam-engine to the valve. It is used because it may be put on the main shaft anywhere without interfering with its continuity and strength.

17. Slotted Cross-head.—The mechanism shown in Fig. 14 is called the “*slotted cross-head mechanism.*” Its centros may be found from principles already given.

This mechanism is often used as follows: One end of c , as E , is attached to a piston working in a cylinder attached to d . This piston is caused to reciprocate by the expansive force of steam or some other fluid. The other end of c is attached to

FIG. 11.

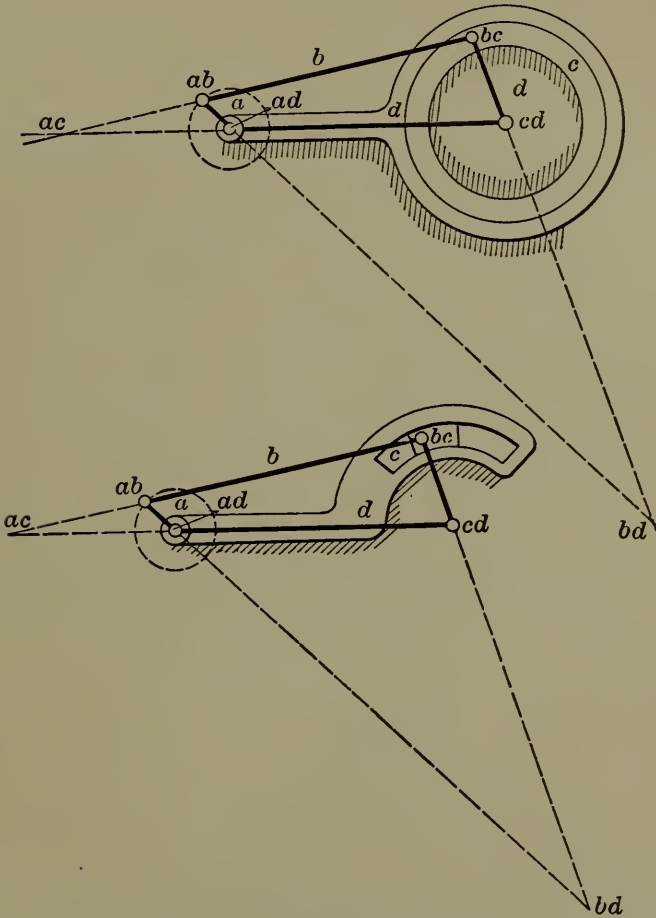

FIG. 12.

another piston, which also works in a cylinder attached to d . This piston may pump water or compress gas (for example small ammonia compressors for refrigerating plants). The crank a is attached to a shaft, the projection of whose axis is ad . This shaft also carries a fly-wheel which insures approximately uniform rotation.

18. Location of Centros in a Compound Mechanism.—It is required to find the centros of the compound linkage, Fig. 15. In any linkage, each link has a centro relatively to every other

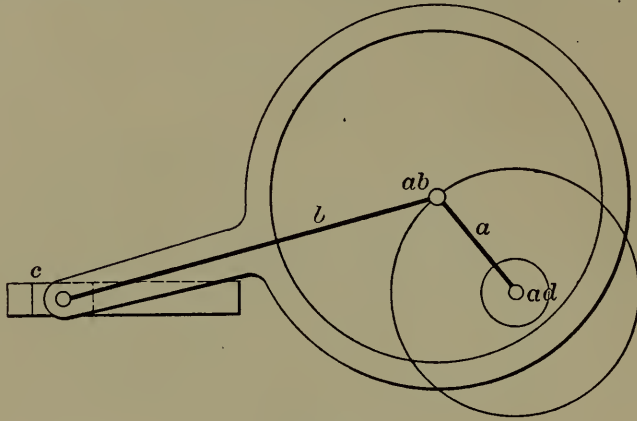

FIG. 13.

link; hence, if the number of links = n , the number of centros = $n(n-1)$. But the centro ab is the same as ba ; i.e., each centro

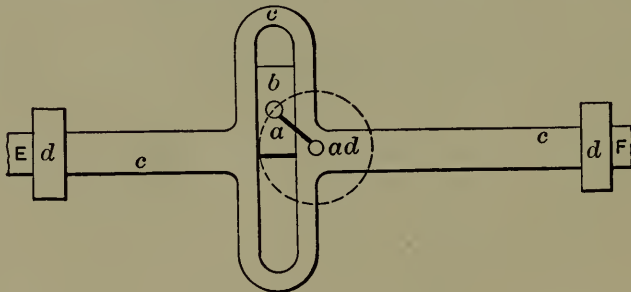

FIG. 14.

is double. Hence the number of centros to be located for any

linkage = $\frac{n(n-1)}{2}$. In the linkage Fig. 15, the number of centros

$$= \frac{6 \times 5}{2} = 15.*$$

* The links are $a, b, c, d, e,$ and f .

The centros: $ab \ bc \ cd \ de \ ef$

$ac \ bd \ ce \ df$

$ad \ be \ cf$

$ae \ bf$

af

The portion above the link d is a slider-crank chain, and the character of its motion is in no way affected by the attachment of the part below d . On the other hand, the lower part is a lever-crank chain, and the character of its motion is not affected by its attachment to the upper part. The chain may therefore be treated in two parts, and the centros of each part may be located from what has preceded. Each part will have six centros, and twelve would thus be located. ad , however, is common to

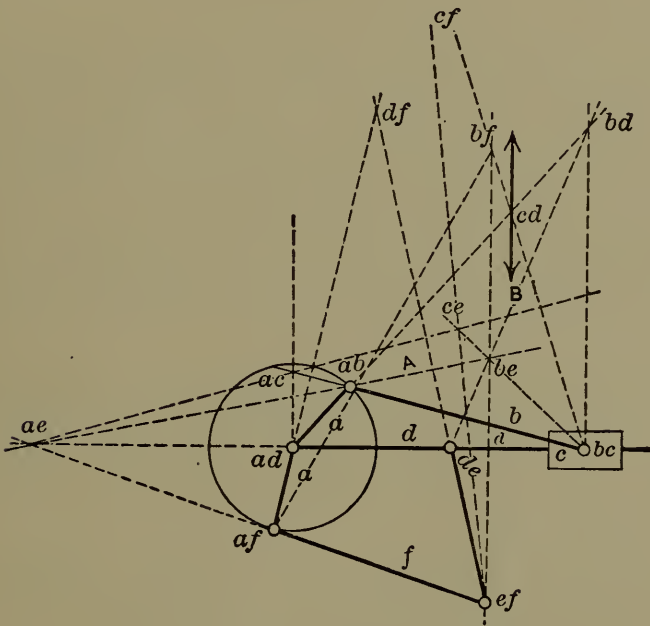

FIG. 15.

the two parts, and hence only eleven are really found. Four centros, therefore, remain to be located. They are be , cf , bf , and ce . To locate be , consider the three links a , b , and e , and it follows that be is in the line A passing through ab and ae ; considering b , d , and e , it follows that be is in the line B through bd and de . Hence be is at the intersection of A and B . Similar methods locate the other centros.

In general, for finding the centros of a compound linkage of

six links, consider the linkage to be made up of two simple chains, and find their centros independently of each other. Then take the two links whose centro is required, together with one of the links carrying three motion elements (as *a*, Fig. 15). The centros of these links locate a straight line, *A*, which contains the required centro. Then take the two links whose centro is required, together with the other link which carries three motion elements. A straight line, *B*, is thereby located, which contains the required centro, and the latter is therefore at the intersection of *A* and *B*.

19. Velocity is the rate of motion, or motion per unit time.

Linear velocity is linear space moved through in unit time; it may be expressed in any units of length and time; as, miles per hour, feet per minute or per second, etc.

Angular velocity is angular space moved through in unit time. In machines, angular velocity is usually expressed in revolutions per minute or per second.

The linear space described by a point in a rotating body, or its linear velocity, is directly proportional to its radius, or its distance from the axis of rotation. This is true because arcs are proportional to radii.

If *A* and *B* are two points in a rotating body, and if r_1 and r_2 are their radii, then the ratio of linear velocities

$$\frac{\text{linear veloc. } A}{\text{linear veloc. } B} = \frac{r_1}{r_2}.$$

This is true whether the rotation is about a center or a centro; *i.e.*, it is true either for continuous or instantaneous rotation. Hence it applies to all cases of plane motion in machines; because all plane motion in machines is equivalent to either continuous or instantaneous rotation about some point.

To find the relation of linear velocity of two points in a machine member, therefore, it is only necessary to find the relation of

the radii of the points. The latter relation can easily be found when the center or centro is located.

20. A vector quantity possesses magnitude and direction. It may be represented by a straight line, because the latter has magnitude (its length) and direction. Thus the length of a straight line, AB , may represent, upon some scale, the magnitude of some vector quantity, and it may represent the vector quantity's direction by being parallel to it, or by being perpendicular to it. For convenience the latter plan will here be used. The vector quantities to be represented are the linear velocities of points in mechanisms. The lines which represent vector quantities are called vectors.

A line which represents the linear velocity of a point will be called the linear velocity vector of the point. The symbol of linear velocity will be Vl . Thus VlA is the linear velocity of the point A . Also Va will be used as the symbol of angular velocity.

If the linear velocity and radius of a point are known, the angular velocity, or the number of revolutions per unit time, may be found; since the linear velocity \div length of the circumference in which the point travels = angular velocity.

All points of a rigid body have the same angular velocity.

If the radii, and ratio of linear velocities of two points, in different machine members are known, the ratio of the angular velocities of the members may be found as follows:

Let A be a point in a member M , and B a point in a member N . r_1 = radius of A ; r_2 = radius of B . VlA and VlB represent the linear velocities of A and B , whose ratio, $\frac{VlA}{VlB}$, is known.

$$\text{Then} \quad VaA = \frac{VlA}{2\pi r_1} \quad \text{and} \quad VaB = \frac{VlB}{2\pi r_2}.$$

$$\text{Hence} \quad \frac{VaA}{VaB} = \frac{VlA}{2\pi r_1} \times \frac{2\pi r_2}{VlB} = \frac{VlA}{VlB} \times \frac{r_2}{r_1} = \frac{VaM}{VaN}.$$

If M and N rotate uniformly about fixed centers, the ratio $\frac{VaM}{VaN}$ is constant. If either M or N rotates about a centro, the ratio is a varying one.

21. To find the relation of linear velocity of two points in the same link, it is only necessary to measure the radii of the points, and the ratio of these radii is the ratio of the linear velocities of the points.

In Fig. 16, let the smaller circle represent the path of A , the center of the crank-pin of a slider-crank mechanism; the link d being fixed. Let the larger circle represent the rim of a pulley which is keyed to the same shaft as the crank. The pulley and the crank are then parts of the same link. The ratio of velocity of the crank-pin center and the pulley surface = $\frac{VIA}{VIB}$

= $\frac{r}{r_1}$. In this case the link rotates about a fixed center. The same relation holds, however, when the link rotates about a centro.

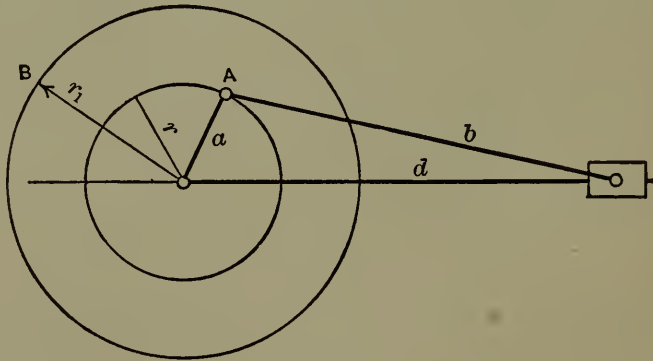

FIG. 16.

22. Velocity Diagram of Slider-crank Chain.—In Fig. 17, the link d is fixed and $\frac{Vlab}{Vlbc} = \frac{ab-bd}{bc-bd}$. By similar triangles this expression is also equal to $\frac{ab-O}{O-A}$. Hence, if the radius of the

crank circle be taken as the vector of the constant linear velocity of ab , the distance cut off on the vertical through O by the line of the connecting-rod (extended if necessary) will be the vector of the linear velocity of bc . Project A horizontally upon bc - bd , locating B . Then bc - B is the vector of Vl of the slider, and may be

FIG. 17.

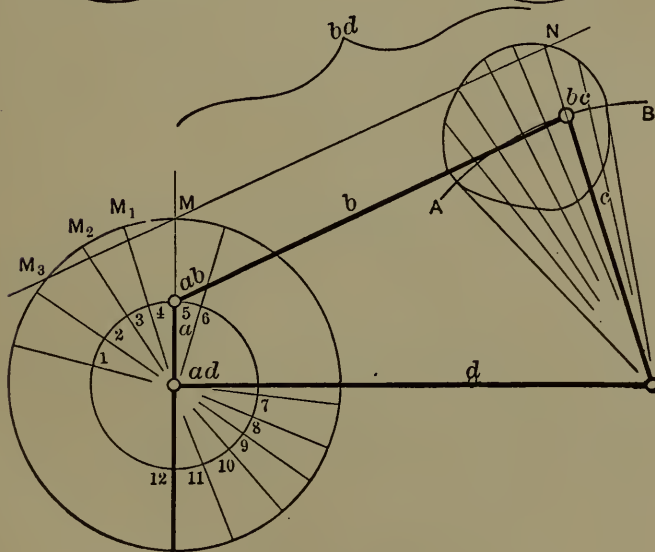
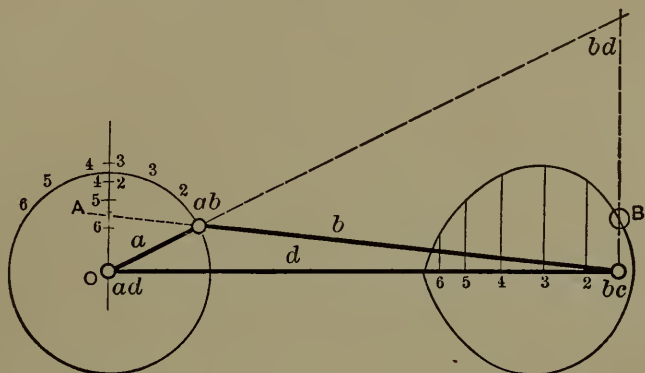

FIG. 18.

used as an ordinate of the linear velocity diagram of the slider. By repeating the above construction for a series of positions, the ordinates representing the Vl of bc for different positions of the slider may be found. A smooth curve through the extremities of these ordinates is the velocity curve, from which the Vl s

of all points of the slider's stroke may be read. The scale of velocities, or the linear velocity represented by one inch of ordinate, equals the constant linear velocity of ab divided by $O-ab$ in inches.

23. Velocity Diagram of Lever-crank Chain.—It is required to find Vl of bc during a cycle of action of the mechanism shown in Fig. 18, d being fixed, and Vl of ab being constant. The two points ab and bc may both be considered in the link b . All points in b move about bd relatively to the fixed link.

Hence
$$\frac{Vlab}{Vlbc} = \frac{ab-bd}{bc-bd}.$$

For most positions of the mechanism bd will be so located as to make it practically impossible to measure these radii, but a line, as MN , drawn parallel to b cuts off on the radii portions which are proportional to the radii themselves, and hence proportional to the Vls of the points. Hence

$$\frac{Vlab}{Vlbc} = \frac{ab-M}{bc-N}.$$

The arc in which bc moves may be divided into any number of parts, and the corresponding positions of ab may be located. A circle through M , with ad as center, may be drawn, and the constant radial distance $ab-M$ may represent the constant velocity of ab . Through M_1, M_2 , etc., draw lines parallel to the corresponding positions of b , and these lines will cut off on the corresponding line of c a distance which represents Vl of bc . Through the points thus determined the velocity diagram may be drawn, and the Vl of bc for a complete cycle is determined. The scale of velocities is found as in Sec. 22.

24. The relation of linear velocity of points not in the same link may also be found.

Required $\frac{Vl \text{ of } A}{Vl \text{ of } B}$ referred to d as the fixed link, Fig. 19.

The centro ab is a point in common to a and b , the two links considered. Consider ab as a point in a ; and its Vl is to that of A as their radii or distances from ad . Draw a vector triangle with its sides parallel to the triangle formed by joining A , ab ,

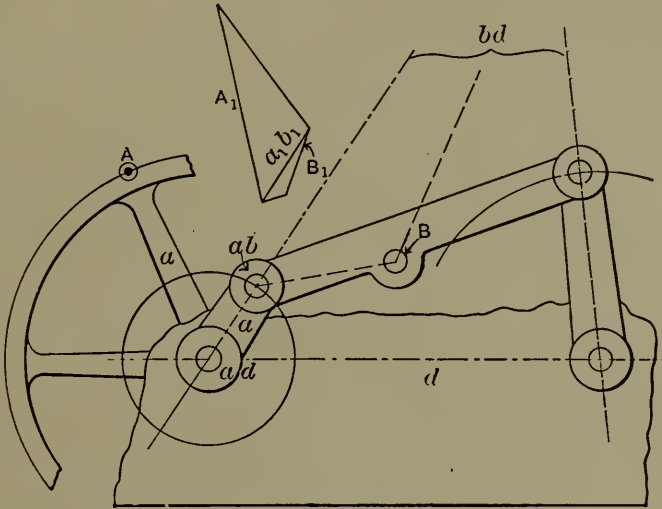

FIG. 19.

and ad . Then if the side A_1 represent the Vl of A , the side a_1b_1 will represent the Vl of ab . Consider ab as a point in b , and its Vl is to that of B as their radii, or distances to bd . Upon the vector a_1b_1 draw a triangle whose sides are parallel to those of a triangle formed by joining ab , bd , and B . Then, from similar triangles, the side B_1 is the vector of B 's linear velocity.

Hence
$$\frac{Vl \text{ of } A}{Vl \text{ of } B} = \frac{\text{vector } A_1}{\text{vector } B_1}.$$

The path of B during a complete cycle may be traced, and the Vl for a series of points may be found, by the above method; then the vectors may be laid off on normals to the path through the points; the velocity curve may be drawn; and the velocity of B at all points becomes known.

25. **Angularity of Connecting-rod.**—The diagram of Vl of the slider-crank mechanism, Fig. 17, is unsymmetrical with respect to a vertical axis through its center. This is due to the angularity of the connecting-rod, and may be explained as follows:

In Fig. 20, AO is one angular position of the crank, and BO is the corresponding angular position on the other side of the vertical through the center of rotation. The corresponding positions of the slider are as shown. But for position A the line of the connecting-rod, C , cuts off on the vertical through O a vector Oa , which represents the slider's velocity. For position B the vector of the slider's velocity is Ob and the velocity diagram is unsymmetrical.

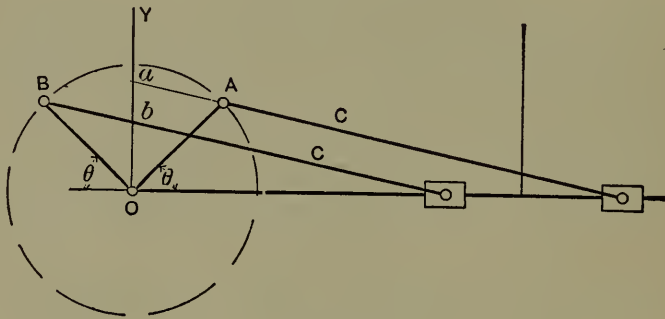

FIG. 20.

If the connecting-rod were parallel to the direction of the slider's motion in all positions, as in the slotted cross-head mechanism (see Fig. 14), the vector cut off on the vertical through O would be the same for position A and position B and the velocity diagram would be symmetrical.

Since the velocity diagram is symmetrical with a parallel connecting-rod and unsymmetrical with an angular connecting-rod, with all other conditions constant, it follows that the lack of symmetry is due to the angularity of the connecting-rod.

The velocity diagram for the slotted cross-head mechanism is symmetrical with respect to both vertical and horizontal axes through its center. In fact, if the crank radius (=length of

link a) be taken as the vector of the Vl of ab , the linear velocity diagram of the slider becomes a circle whose radius = the length of the link a . Hence the crank circle itself serves for the linear velocity diagram, the horizontal diameter representing the path of the slider.

26. Angularity of Connecting-rod, Continued.—During a portion of the cycle of the slider-crank mechanism, the slider's Vl is greater than that of ab . This is also due to the angularity of the connecting-rod, and may be explained as follows: In Fig. 21, as the crank moves up from the position x , it will reach such a position, A , that the line of the connecting-rod extended will pass through B . OB in this position is the vector of the linear velocity of both ab and the slider, and hence their linear velocities

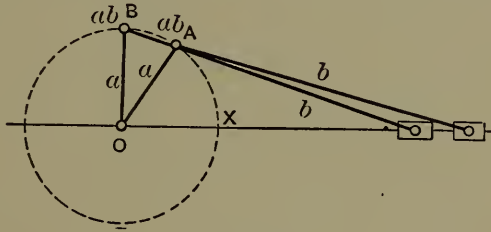

FIG. 21.

are equal. When ab reaches B , the line of the connecting-rod passes through B ; and again the vectors—and hence the linear velocities—of ab and the slider are equal. For all positions between A and B the line of the connecting-rod will cut OB outside of the crank circle; and hence the linear velocity of the slider will be greater than that of ab . This result is due to the angularity of the connecting-rod, because if the latter remained always horizontal, its line could never cut OB outside the circle. It follows that in the slotted cross-head mechanism the maximum Vl of the slider = the constant Vl of ab . The angular space BOA , Fig. 21, throughout which Vl of the slider is greater than the Vl of ab , increases with increase of angularity of the connecting-rod; *i.e.*, it increases with the ratio

$$\frac{\text{Length of crank}}{\text{Length of connecting-rod}}.$$

27. Quick-return Mechanisms.—A slider in a mechanism often carries a cutting-tool, which cuts during its motion in one direction, and is idle during the return stroke. Sometimes the slider carries the piece to be cut, and the cutting occurs while it passes under a tool made fast to the fixed link, the return stroke being idle.

The velocity of cutting is limited. If the limiting velocity be exceeded, the tool becomes so hot that its temper is drawn, and it becomes unfit for cutting. The limit of cutting velocity depends on the nature of the material to be cut. Thus annealed tool-steel and the scale surface of cast iron may be cut with carbon tool-steel at 10 to 20 feet per minute; wrought iron and soft steel at 25 to 30 feet per minute; while brass and the softer alloys may be cut at 40 or more feet per minute. With certain special tool-steels these speeds may be considerably exceeded. There is no limit of this kind, however, to the velocity during the idle stroke; and it is desirable to make it as great as possible, in order to increase the product of the machine. This leads to the design and use of "quick-return" mechanisms.

28. Slider-crank Quick Return.—If, in a slider-crank mechanism, the center of rotation of the crank be moved, so that the line of the slider's motion does not pass through it, the slider will have a quick-return motion.

In Fig. 22, when the slider is in its extreme position at the right, *A*, the crank-pin center is at *D*. When the slider is at *B*, the crank-pin center is at *C*. If rotation is as indicated by the arrow, then, while the slider moves from *B* to *A*, the crank-pin center moves from *C* over to *D*. And while the slider returns from *A* to *B*, the crank-pin center moves under from *D* to *C*. If the *V* of the crank-pin center be assumed constant, the time occupied in moving from *D* to *C* is less than that from *C* to *D*. Hence the time occupied by the slider in moving from *B* to *A* is greater than that occupied in moving from *A* to *B*. The

mean velocity during the forward stroke is therefore less than during the return stroke. Or the slider has a "quick-return" motion.

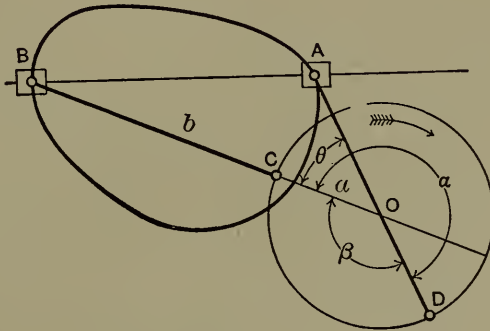

FIG. 22.

It is required to design a mechanism of this kind for a length of stroke = BA and for a ratio

$$\frac{\text{mean } V_l \text{ forward stroke}}{\text{mean } V_l \text{ return stroke}} = \frac{5}{7}.$$

The mean velocity of either stroke is inversely proportional to the time occupied, and the time is proportional to the corresponding angle described by the crank. Hence

$$\frac{\text{mean velocity forward}}{\text{mean velocity return}} = \frac{5}{7} = \frac{\text{angle } \beta}{\text{angle } \alpha}.$$

It is therefore necessary to divide 360° into two parts which are to each other as 5 to 7. Hence $\alpha = 210^\circ$ and $\beta = 150^\circ$. Obviously $\theta = 180^\circ - \beta = 30^\circ$. Place the 30° angle of a drawing triangle so that its sides pass through B and A . This condition may be fulfilled and yet the vertex of the triangle may occupy an indefinite number of positions. By trial O may be located so that the crank shall not interfere with the line of the slider.*

*To avoid cramping of the mechanism, the angle BAD should equal or exceed 135° .

O being located tentatively, it is necessary to find the corresponding lengths of crank a and connecting-rod b . When the crank-pin center is at D , $AO = b - a$; when it is at C , $BO = b + a$. AO and BO are measurable values of length; hence a and b may be found, the crank circle may be drawn, and the velocity diagrams may be constructed as in Fig. 17; remembering that the distance cut off upon a vertical through O , by the line of the connecting-rod, is the vector of the Vl of the slider for the corresponding position when the Vl of the crank-pin center is represented by the crank radius.

It is required to make the maximum velocity of the forward stroke of the slider = 20 feet per minute, and to find the corresponding number of revolutions per minute of the crank. The maximum linear velocity vector of the forward stroke = the maximum height of the upper part of the velocity diagram; call it Vl_1 . Call the linear velocity vector of the crank-pin center Vl_2 = crank radius. Let x = linear velocity of the crank-pin center. Then

$$\frac{Vl_1}{Vl_2} = \frac{20 \text{ ft. per minute}}{x},$$

or

$$x = \frac{20 \text{ ft. per minute} \times Vl_2}{Vl_1}.$$

x is therefore expressed in known terms. If now x , the space the crank-pin center is required to move through per minute, be divided by the space moved through per revolution, the result will equal the number of revolutions per minute = N ;

$$N = \frac{x}{2\pi \times \text{length of crank}}.$$

29. Lever-crank Quick Return.—Fig. 23 shows a compound mechanism. The link d is the supporting frame or fixed link, and a rotates about ad in the direction indicated, communicating

motion to c through the slider b so that c vibrates about cd . The link e , connected to c by a turning pair at ce , causes f to slide horizontally on another part of the frame or fixed link d . The center of the crank-pin, ab , is given a constant linear velocity, and the slider, f , has motion toward the left with a certain mean velocity, and returns toward the right with a greater mean velocity. This is true because the slider f moves toward the left while a moves through the angle α ; and toward the right while a moves through the angle β . But the motion of a is uniform, and hence the angular movement α represents more time than the angular movement β ; and f , therefore, has more time to move toward the left than it has to move through the same space toward the right. It therefore has a "quick-return" motion.

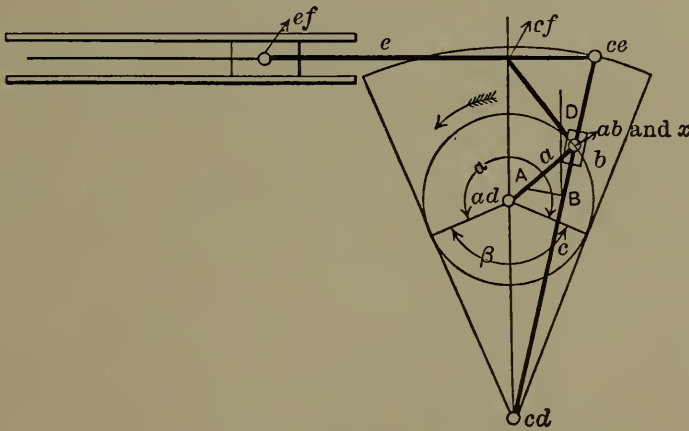

FIG. 23.

The machine is driven so that the crank-pin center moves uniformly, and the velocity, at all points of its stroke, of the slider carrying a cutting-tool, is required. The problem, therefore, is to find the relation of linear velocities of ef and ab for a series of positions during the cycle; and to draw the diagram of velocity of ef .

Solution.— ab has a constant known linear velocity. The point in the link c which coincides, for the instant, with ab , receives motion from ab , but the direction of its motion is different

from that of ab , because ab rotates about ad , while the coinciding point of c rotates about cd . If $ab-A$ be laid off representing the linear velocity of ab , then $ab-B$ will represent the linear velocity of the coinciding point of the link c . Let the latter point be called x .

Locate cf , at the intersection of e with the line $cd-ad$. Now cf and x are both points in the link c , and hence their linear velocities, relatively to the fixed link d , are proportional to their distances from cd . These two distances may be measured directly, and with the known value of linear velocity of $x=ab-B$ give three known values of a simple proportion, from which the fourth term, the linear velocity of cf , may be found.

Or, if the line BD be drawn parallel to $cd-ad$, the triangle $B-D-ab$ is similar to the triangle $cd-cf-ab$, and from the similarity of these triangles it follows that BD represents the linear velocity of cf on the same scale that $ab-B$ represents the linear velocity of x . Hence the linear velocity of cf , for the assumed position of the mechanism, becomes known. But since cf is a point of the slider, all of whose points have the same linear velocity because its motion relatively to d is rectilinear translation, it follows that the linear velocity of cf is the required linear velocity of the slider. At cf erect a line perpendicular to the direction of motion of the slider having a length equal to BD .

This solution may be made for as many positions of the mechanism as are necessary to locate accurately the velocity curve. The ordinates of this curve will, of course, be the velocities of the slider, and the abscissæ the corresponding positions of the slider.

Having drawn the velocity diagram, suppose that it is required to make the maximum linear velocity of the slider on the slow stroke = Q feet per minute. Then the linear velocity of the crank-pin center $ab=y$ can be determined from the proportion

$$\frac{y}{Q} = \frac{\text{vector } A-ab}{\text{maximum ordinate of velocity diagram}}$$

$$\therefore y = Q \frac{\text{vector } A-ab}{\text{maximum ordinate of velocity diagram}}$$

If r = the crank radius, the number of revolutions per minute = $\frac{y}{2\pi r}$.

When this mechanism is embodied in a machine, a becomes a crank attached to a shaft whose axis is at ad . The shaft turns in bearings provided in the machine frame. The crank carries a pin whose axis is at ab , and this pin turns in a bearing in the sliding block b . The link c becomes a lever keyed to a shaft whose axis is at cd . This lever has a long slot in which the block b slides. The link e becomes a connecting-rod, connected to both c and f by pin and bearing. The link f becomes the "cutter-bar" or "ram" of a shaper: the part which carries the cutting-tool. The link d becomes the frame of the machine, which not only affords support to the shafts at ad and cd , and the guiding surfaces for f , but also is so designed as to afford means for holding the pieces to be planed, and supports the feed mechanism.

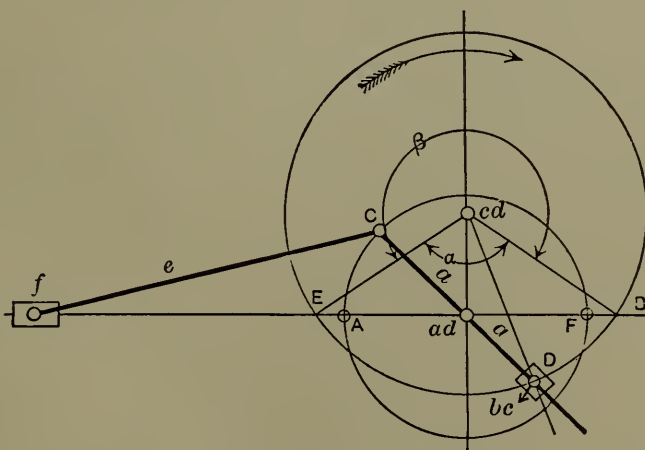

FIG. 24.

30. **Whitworth Quick Return.**—Fig. 24 shows another compound linkage. d is fixed, and c rotates uniformly about cd ,

communicating an irregular rotary motion to a through the slider b . a is extended past ad (the part extended being in another parallel plane), and moves a slider f through the medium of a link e . This is called the "Whitworth quick-return mechanism." The point bc , at which c communicates motion to a , moves along a , and hence the radius (measured from ad) of the point at which a receives a constant linear velocity varies, and the angular velocity of a must vary inversely. Hence the angular velocity of a is a maximum when the radius is a minimum, *i.e.*, when a and c are vertical downward; and the angular velocity of a is minimum when the radius is a maximum, *i.e.*, when a and c are vertical upward.

31. Problem.—To design a Whitworth Quick Return for a given ratio,

$$\frac{\text{mean } Vl \text{ of } f \text{ forward}}{\text{mean } Vl \text{ of } f \text{ returning}}$$

When the center of the crank-pin, C , reaches A , the point D will coincide with B , the link c will occupy the angular position $cd-B$, and the slider f will be at its extreme position toward the left.

When the point C reaches F , the point D will coincide with E , the link c will occupy the angular position $cd-E$, and the slider f will be at its extreme position toward the right.

Obviously, while the link c moves *over* from the position $cd-E$ to the position $cd-B$, the slider f will complete its forward stroke, *i.e.*, from right to left. While c moves *under* from $cd-B$ to $cd-E$, f will complete the return stroke, *i.e.*, from left to right. The link c moves with a uniform angular velocity, and hence the mean velocity of f forward is inversely proportional to the angle β (because the time consumed for the stroke is proportional to the angle moved through by the crank c), and the mean velocity of f returning is inversely proportional to α . Or

$$\frac{\text{mean } Vl \text{ of } f \text{ forward}}{\text{mean } Vl \text{ of } f \text{ returning}} = \frac{\alpha}{\beta}$$

For the design the distance $cd-ad$ must be known. This may usually be decided on from the limiting sizes of the journals at cd and ad . Suppose that the above ratio $=\frac{\alpha}{\beta}=\frac{5}{7}$, that $cd-ad=3''$, and that the maximum length of stroke of $f=12''$. Locate cd and measure off vertically downward a distance equal to $3''$, thus locating ad . Draw a horizontal line through ad . The point ef of the slider f will move along this line. Since

$$\frac{\alpha}{\beta}=\frac{5}{7}, \quad \text{and } \alpha+\beta=360^{\circ},$$

$$\therefore \alpha=150^{\circ} \quad \text{and} \quad \beta=210^{\circ}.$$

Lay off α from cd as a center, so that the vertical line through cd bisects it. Draw a circle through B with cd as a center, B being the point of intersection of the bounding line of α with a horizontal through ad . The length of the link $c=cd-B$.

The radius $ad-C$ must equal the travel of $f \div 2=6''$. This radius is made adjustable, so that the length of stroke may be varied. The connecting-rod, e , may be made of any convenient length.

32. Problem.—To draw the velocity diagram of the slider f of the Whitworth Quick Return. The point bc , Fig. 25, as a point of c has a known constant linear velocity relative to d , and its direction of motion is always at right angles to a line joining it to cd . That point of the link a which coincides in this position of the mechanism with bc , receives motion from bc , but its direction of motion relative to d is at right angles to the line $bc-ad$. If $bc-A$ represents the linear velocity of bc , its projection upon $bc-ad$ extended will represent the linear velocity of the point of a which coincides with bc . Call this point x . Locate the centro af , draw the line $af-bc$ and extend it to meet the vertical dropped from B to C . The centro af may be considered as a

point in a , and its linear velocity relative to d , when so considered, is proportional to its distance from ad . Hence

$$\frac{Vl \text{ of } aj}{Vl \text{ of } x} = \frac{ad-aj}{ad-bc}.$$

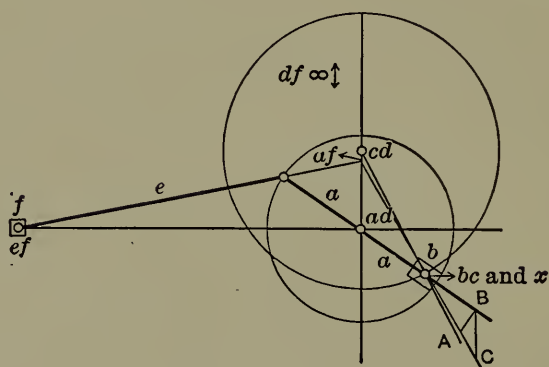

FIG. 25.

But the triangles $ad-aj-bc$ and $B-C-bc$ are similar. Hence

$$\frac{Vl \text{ of } aj}{Vl \text{ of } x} = \frac{BC}{B-bc}.$$

This means that BC represents the linear velocity of aj upon the same scale that $B-bc$ represents the linear velocity of x . But aj is a point in f , and all points in f have the same linear velocity relative to d since the motion is rectilinear translation; hence BC represents the linear velocity of the slider f for the given position of the mechanism, and it may be laid off as an ordinate of the velocity curve. This solution may be made for as many positions as are required to locate accurately the entire velocity curve for a cycle of the mechanism.

CHAPTER III.

PARALLEL OR STRAIGHT-LINE MOTIONS.

33. Watt Parallel Motion.—Rectilinear motion in machines is usually obtained by means of prismatic guides. It is sometimes necessary, however, to accomplish the same result by linkages.

The simplest and most widely known linkage used for giving rectilinear motion to a point without the use of any sliding pairs is the so-called *Watt Parallel Motion*. It is one of the numerous inventions of James Watt and consists of four links, three moving and one fixed, all connected by turning pairs. d , Fig. 26, is the fixed link. a rotates relative to d about ad ; c rotates relative to d about cd .

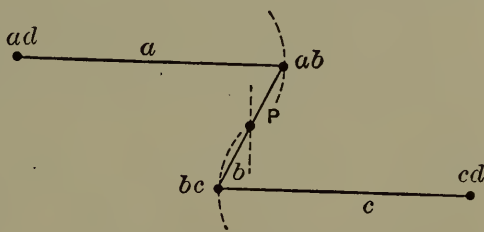

The mechanism is shown in the position corresponding to the middle of its motion.

As the points ab and bc swing in the dotted arcs, the point P will travel in approximately a straight line. The whole path of P is a lemniscate, but the part which is ordinarily used approaches very closely to a straight line.

34. Parallelogram.—A true parallel motion is given by the *Parallelogram* which is shown in Fig. 27. The links a , b , c , and e are connected to each other by turning pairs, and the linkage is attached to the fixed link d by a turning pair at ac . (This point is also ad and cd .)

The lengths $ac-ab$ and $ce-be$ are equal, as are also $ac-ce$ and $ab-be$. The point P is fixed on e . Draw a line from P to ac ; it

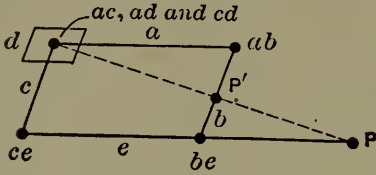

cuts the link b at P' .

By similar triangles,

$$\frac{P'-be}{ac-ce} = \frac{P-be}{P-ce}$$

FIG. 27.

$$\therefore P'-be = ac-ce \left(\frac{P-be}{P-ce} \right) = \text{a constant.}$$

Therefore the point P' will lie at the same position on b for all positions of the mechanism. Likewise, by similar triangles, the

ratio $\frac{P-ac}{P'-ac} = \frac{P-ce}{P-be} = \text{a constant}$ for all positions of the mechanism.

Since both P and P' rotate relative to d about the point ad (at ac) at every instant, it is obvious that their motions relative to d will be similar to each other in every respect and always in the ratio $\frac{P-ac}{P'-ac}$. It follows that, if either of these points is guided to move in a straight-line path, the other point is constrained to move in a similar parallel path.

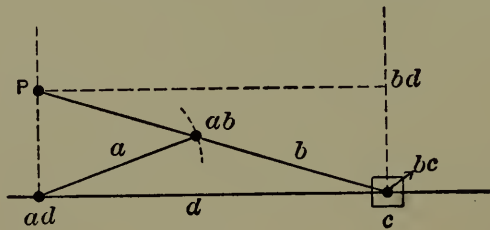

FIG. 28.

35. Grasshopper Motion.—A device which may be used to change the direction of rectilinear motion through a right angle is the linkage known as the *Grasshopper Motion*, shown in Fig. 28. This is the ordinary slider-crank chain with crank a and connecting-rod b of equal length. The linkage is further modified

by extending b beyond ab to a point P such that the length $P-ab = \text{crank length}$. It is obvious that P is constrained to move relative to d in a straight-line path perpendicular to d through ad .*

36. General Method for Parallel-motion Design.—A general method of design which is applicable in many cases is as follows. In Fig. 29 d is the fixed link, and a is connected with it by a sliding pair. $a, b, c,$ and e are connected by turning pairs, as shown. The constraint is not complete because B is free to move in any direction, and its motion would, therefore, depend upon the force producing it. It is required that the point B shall move

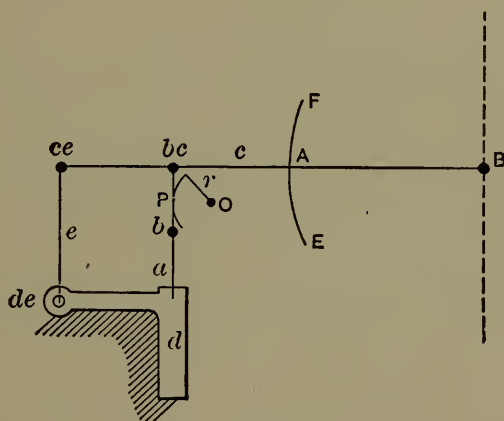

FIG. 29.

in a straight line parallel to a . Suppose that B is caused to move along the required line; then any point of the link c , as A , will describe some curve, FAE . If a pin be attached to c , with its axis at A , and a curved slot fitting the pin, with its sides parallel to FAE , be attached to d , as in Fig. 30, it follows that B can only move in the required straight line. This is the mechanism of the Tabor Steam-engine Indicator.

* This is true because, from the construction of the mechanism, the line $P-bd$ must always lie parallel to d . The point P , which rotates about bd as center relatively to d , always has an instantaneous motion perpendicular to $P-bd$ and, consequently, perpendicular to d .

The curve described by A might approximate a circular arc whose center could be located, say, at O , Fig. 30. Then the

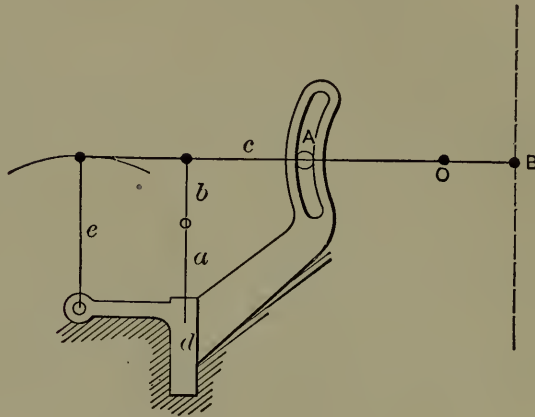

FIG. 30.

curved slot might be replaced by a link attached to d and c by turning pairs at O and A . This gives B approximately the required motion. This is the mechanism of the Thompson Steam-engine Indicator.

If, while the point B is caused to move in the required straight line, a point in b , as P , Fig. 29, were chosen, it would be found

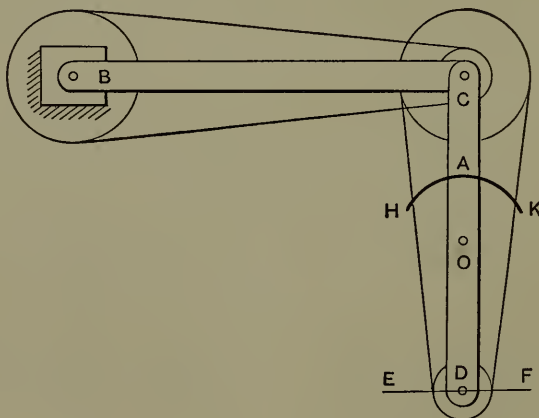

FIG. 31.

to describe a curve which would approximate a circular arc, whose center, O , and radius, $=r$, could be found. Let the link

whose length = r be attached to d and b by turning pairs whose axes are at O and P , and the motion of B will be approximately the required motion. This is the mechanism of the Crosby Steam-engine Indicator.

37. Problem.—In Fig. 31 B is the fixed axis of a counter-shaft; C is the axis of another shaft which is free to move in any direction. It is required to constrain D to move in the straight line EF . If D be moved along EF , a tracing-point fixed at A in the link CD will describe an approximate circular arc, HAK , whose center may be found at O . A link whose length is OA may be connected to the fixed link, and to the link CD , by means of turning pairs at O and A . D will then be constrained to move approximately along EF . A curved slot and pin could be used, and the motion would be exact.*

* Descriptions of many varieties of parallel motions may be found in Rankine's "Machinery and Millwork"; Weisbach's "Mechanics of Engineering," Vol. III, "Mechanics of the Machinery of Transmission"; Kennedy's "Mechanics of Machinery"; and elsewhere.

CHAPTER IV.

CAMS.

38. Cams Defined.—A machine part of irregular outline, as *A*, Fig. 32, may rotate or vibrate about an axis *O*, and communicate motion by line contact to another machine part, *B*. *A* is called a cam. A cylinder *A*, Fig. 33, having a groove of any form in its surface, may rotate about its axis, *CD*, and communicate motion to another machine part, *B*. *A* is a cam. A disk *A*, Fig. 34, having a groove in its face, may rotate about its axis, *O*, and communicate motion to another machine part, *B*. *A* is a cam. In fact it is only a modification of *A*, Fig. 32. In designing cams it is customary to consider a number of simultaneous positions of the driver and follower. The cam curve can usually be drawn from data thus obtained.

39. Case I.—The follower is guided in a straight line, and the contact of the cam with the follower is always in this line. The line may be in any position relatively to the center of rotation of the cam; hence it is a general case. The point of the follower which bears on the cam is constrained to move in the line *MN*, Fig. 35. *O* is the center of rotation of the cam. About *O* as a center, draw a circle tangent to *MN* at *J*. Then *A*, *B*, *C*, etc., are points in the cam. When the point *A* is at *J* the point of the follower which bears on the cam must be at *A'*; when *B* is at *J* the follower-point must be at *B'*; and so on through an entire revolution. Through *A*, *B*, *C*, etc., draw lines tangent

to the circle. With O as a center, and OA' as a radius, draw a circular arc $A'A''$, intersecting the tangent through A at A'' . Then A'' will be a point in the cam curve. For, if A returns to J , AA'' will coincide with JA' , A'' will coincide with A' , and the

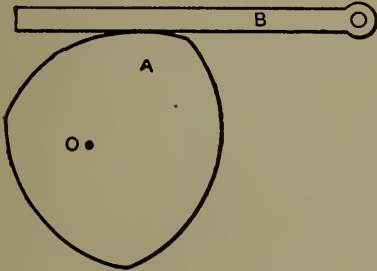

FIG. 32.

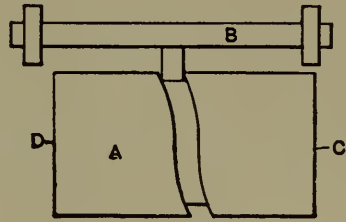

FIG. 33.

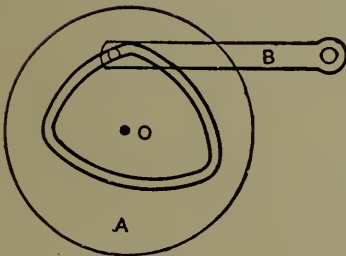

FIG. 34.

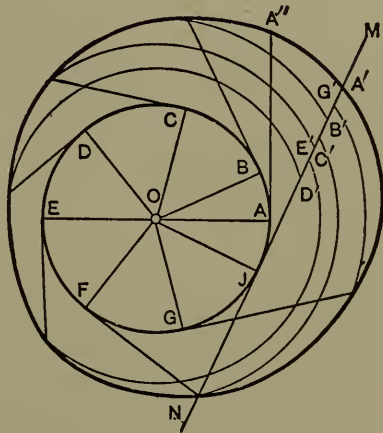

FIG. 35.

cam will hold the follower in the required position. The same process for the other positions locates other points of the cam curve. A smooth curve drawn through these points is the required cam outline. Often, to reduce friction, a roller attached to the follower rests on the cam, motion being communicated through it. The curve found as above will be the path of the axis of the roller. The cam outline will then be a curve drawn

inside of, and parallel to, the path of the axis of the roller, at a distance from it equal to the roller's radius. Contact between the follower and the cam is not confined to the line MN if a roller is used.

40. Case II.—The cam engages with a surface of the follower, and this surface is guided so that all of its positions are parallel. The method given is due to Professor J. H. Barr. O , Fig. 36, is the center of rotation of the cam. The follower surface occupies the successive positions 1, 2, 3, etc., when the lines A , B , C , etc., of the cam coincide with the vertical line through C . It is required to draw the outline of a cam to produce the motion required. Produce the vertical line through O , cutting the positions of the follower surface in A' , B' , C' , etc. With O as a center and radii OB' , OC' , etc., draw arcs cutting the lines B , C , D , etc., in the points B'' , C'' , D'' , etc. Position 1 is the lowest position of the follower surface; therefore A must be in contact with the follower surface in the vertical line through O , because if the tangency be at any other point the motion in one direction or the other will lower the follower, which is not allowable. A is therefore one point in the cam curve. Draw a line MN through B'' at right angles to $B''O$, and rotate $B''O$ till it coincides with $B'O$. Then the line MN will coincide with the position of the follower surface $2B'$. But the cam curve must be tangent to this line when B coincides with $B'O$, and therefore the line MN is a line to which the cam curve must be tangent. Similar lines may be drawn through the points C'' , D'' , etc. Each will be a line to which the cam curve must be tangent. Therefore, if a smooth curve be drawn tangent to all these lines, it will be the required cam outline.

41. Case III.—This is the same as Case II, except that the positions of the follower surface, instead of being parallel, converge to a point, O , Fig. 37, about which the follower vibrates. The solution is the same as in Fig. 36, except that the angle be-

tween the lines corresponding to MN , Fig. 36, and the radial lines, instead of being a right angle, equals the angle between the corresponding position of the follower surface and the vertical.

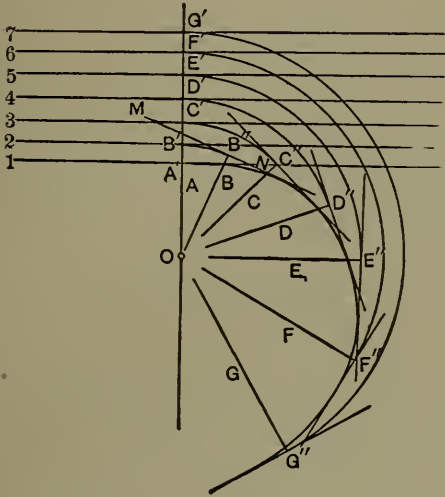

FIG. 36.

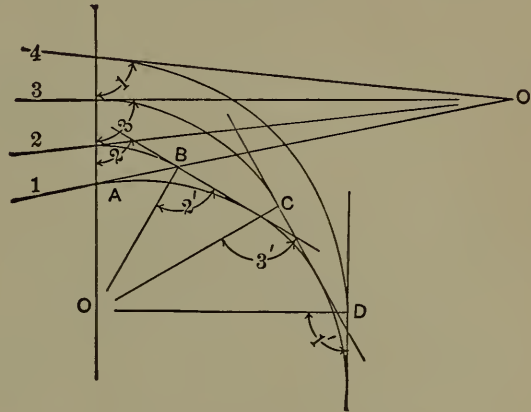

FIG. 37.

In these cases the cam drives the follower in only one direction; the force of gravity, the expansive force of a spring, or some other force must hold it in contact with the cam. To drive the follower in both directions, the cam surface must be double, *i.e.*, it takes the form of a groove engaging with a pin or roller attached to the follower, as in Fig. 34.

This method is inclined to produce excessive wear. A better method is to have the follower provided with two rollers on opposite sides of the cam-shaft. See Fig. 38.

Cam A is designed to give the desired motion to the follower through the medium of roller 1. Every position of this roller causes roller 2 to occupy a definite position, and the complementary cam B is so designed as to correspond to these positions of roller 2. Cam B is rigidly mounted on the same shaft as A , so that the two cams have no motion relative to each other. If the line of action of the follower passes through the center of the cam-

shaft as shown in Fig. 38, it becomes a very simple matter to draw the outline of cam *B*; all that is necessary is to keep the

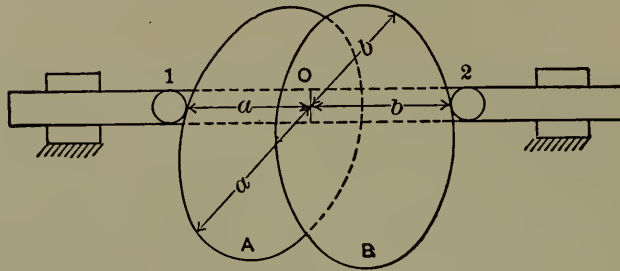

FIG. 38.

sum of the radial lengths $a + b = a$ constant = the distance between the surfaces of rollers 1 and 2.

42. Case IV.—To lay out a cam groove on the surface of a cylinder.—*A*, Fig. 39, is a cylinder which is to rotate continuously about its axis. *B* can only move parallel to the axis of *A*. *B* may have a projecting roller to engage with a groove in the surface of *A*. *CD* is the axis of the roller in its mid-position. *EF* is the development of the surface of the cylinder. During the first quarter-revolution of *A*, *CD* is required to move one inch toward the right with a constant velocity. Lay off $GH = 1''$, and $HJ = \frac{1}{4}KF$, locating *J*. Draw *GJ*, which will be the middle line of the cam-groove. During the next half-revolution of *A* the roller is required to move two inches toward the left with a uniformly accelerated velocity. Lay off $JL = 2''$, and $LM = \frac{1}{2}KF$. Divide *LM* into any number of equal parts, say four. Divide *JL* into four parts, so that each is greater than the preceding one by an equal increment. This may be done as follows: $1 + 2 + 3 + 4 = 10$. Lay off from *J*, $0.1JL$, locating *a*; then $0.2JL$ from *a*, locating *b*; and so on. Through *a*, *b*, and *c* draw vertical lines; through *m*, *n*, and *o* draw horizontal lines. The intersections locate *d*, *e*, and *f*. Through these points draw the curve from *J* to *M*, which will be the required middle line of the cam-groove. During the remaining quarter-revolution

the roller is required to return to its starting-point with a uniformly accelerated velocity. The curve MN is drawn in the same way as JM . On each side of the line $GJMN$ lay off

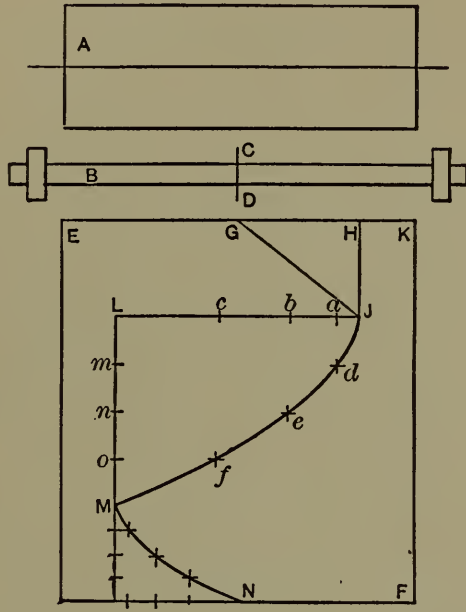

FIG. 39.

parallel lines, their distance apart being equal to the diameter of the roller. Wrap EF upon the cylinder, and the required cam-groove is located.

CHAPTER V.

ENERGY IN MACHINES.

43. The subject of motion and velocity, in certain simple machines, has been treated and illustrated. It remains now to consider the passage of *energy* through similar machines. From this the solution of force problems will follow.

During the passage of energy through a machine, or chain of machines, any one, or all, of four changes may occur.

I. The energy may be transferred in space. *Example.*—Energy is received at one end of a shaft and transferred to the other end, where it is received and utilized by a machine.

II. The energy may be converted into another form. *Examples.*—(a) Heat energy into mechanical energy by the steam-engine machine chain. (b) Mechanical energy into heat by friction. (c) Mechanical energy into electrical energy, as in a dynamo-electric machine; or electrical energy into mechanical energy in the electric motor, etc.

III. Energy is the product of a force factor and a space factor. Energy per unit time, or *rate of doing work*, is the product of a force factor and a velocity factor, since velocity is space per unit time. Either factor may be changed at the expense of the other; *i.e.*, velocity may be changed, if accompanied by such a change of force that the energy per unit time remains constant. Correspondingly, force may be changed at the expense of velocity, energy per unit time being constant. *Example.*—A belt transmits 6000 foot-pounds per minute to a machine. The belt velocity is 120 feet per minute, and the force exerted is 50 lbs. Fric-

tional resistance is neglected. A cutting-tool in the machine does useful work; its velocity is 20 feet per minute, and the resistance to cutting is 300 lbs. Then, energy received per minute = $120 \times 50 = 6000$ foot-pounds; and energy delivered per minute = $20 \times 300 = 6000$ foot-pounds. The energy received therefore equals the energy delivered. But the velocity and force factors are quite different in the two cases.

IV. Energy may be transferred in time. In many machines the energy received at every instant equals that delivered. There are many cases, however, where there is a periodical demand for work, *i.e.*, a fluctuation in the rate of doing work; while energy can only be supplied at the average rate. Or there may be a uniform rate of doing work, and a fluctuating rate of supplying energy. In such cases means are provided in the machine, or chain of machines, for the *storing of energy* till it is needed. In other words, *energy is transferred in time*. *Examples.*—(a) In the steam-engine there is a varying rate of supplying energy during each stroke, while there is (in general) a uniform rate of doing work. There is, therefore, a periodical excess and deficiency of effort. A heavy wheel on the main shaft absorbs the excess of energy with increased velocity, and gives it out again with reduced velocity when the effort is deficient. (b) A pump delivers water into a pipe system under pressure. The water is used in a hydraulic press, whose action is periodic and beyond the capacity of the pump. A hydraulic accumulator is attached to the pipe system, and while the press is idle the pump slowly raises the accumulator weight, thereby storing potential energy, which is given out rapidly by the descending weight for a short time while the press acts. (c) A dynamo-electric machine is run by a steam-engine, and the electrical energy is delivered and stored in storage batteries, upon which there is a periodical demand. In this case, as well as in case (b), there is a transformation of energy as well as a transfer in time.

44. **Force Problems.**—Suppose the slider-crank mechanism in Fig. 40 to represent a shaping-machine, the velocity diagram of

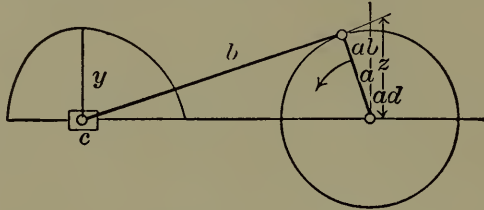

FIG. 40.

the slider being drawn. The resistance offered to cutting metal during the forward stroke must be overcome. This resistance may be assumed constant. Throughout the cutting stroke there is a continually varying *rate of doing work*. This is because the rate of doing work = resisting force (constant) \times velocity (varying). This product is continually varying, and is a maximum when the slider's velocity is a maximum. The slider must be driven by means of energy transmitted through the crank a . The maximum rate at which energy must be supplied equals the maximum rate of doing work at the slider. Draw the mechanism in the position of maximum velocity of slider; * *i.e.*, locate the center of the slider-pin at the base of the maximum ordinate of the velocity diagram, and draw b and a in their corresponding positions. The slider's known velocity is represented by y , and the crank-pin's required velocity is represented by a on the same scale. Hence the value of a becomes known by simple proportion. The rate of doing work must be the same at c and at ab (neglecting friction).† Hence $Rv_1 = Fv_2$, in which R and v_1 represent the

* It is customary to assume the slider's position for this condition to be that corresponding to an angle of 90° between crank and connecting-rod. This is not exactly true, but is a sufficiently close approximation for the ordinary proportions of crank and connecting-rod lengths. For method of exact determination of slider's position see Appendix.

† The effect of acceleration to redistribute energy is zero in this position, because the acceleration of the slider at maximum velocity is zero, and the angular acceleration of b can only produce pressure in the journal at ad .

force and velocity factors at c ; and F and v_2 represent the force and velocity factors at ab . R and v_1 are known from the conditions of the problem, and v_2 is found as above. Hence F may be found, $=\frac{Rv_1}{v_2}$ = force which, applied tangentially to the crank-pin center, will overcome the maximum resistance of the machine. In all other positions of the cutting stroke the rate of doing work is less, and F would be less. But it is necessary to provide driving mechanism capable of overcoming the maximum resistance, when no fly-wheel is used. If now F be multiplied by the crank radius, the product equals the maximum torsional moment ($=M$) required to drive the machine. If the energy is received on some different radius, as in case of gear or belt transmission, the maximum driving force $= M \div$ the new radius. During the return stroke the cutting-tool is idle, and it is only necessary to overcome the frictional resistance to motion of the bearing surfaces. Hence the return stroke is not considered in designing the driving mechanism. When the *method* of driving this machine is decided on, the *capacity* of the driving mechanism must be such that it shall be capable of supplying to the crank-shaft the torsional driving moment M , determined as above.

This method applies as well to the quick-return mechanisms given. In each, when the velocity diagram is drawn, the vector of the maximum linear velocity of the slider, $=L_1$, and of the constant linear velocity of the crank-pin center, $=L_2$, are known, and the velocities corresponding, v_1 and v_2 , are also known, from the scale of velocities. The rate of doing work at the slider and at the crank-pin center is the same, friction being neglected. Hence $Rv_1 = Fv_2$, or, since the vector lengths are proportional to the velocities they represent, $RL_1 = FL_2$; and $F = \frac{RL_1}{L_2}$. Therefore the resistance to the slider's motion $=R$, on the cutting

stroke, multiplied by the ratio of linear velocity vectors, $\frac{L_1}{L_2}$, of slider and crank-pin, equals F , the maximum force that must be applied tangentially at the crank-pin center to insure motion. F multiplied by the crank radius = maximum torsional driving moment required by the crank-shaft. If R is varying and known, find where Rv , the rate of doing work, is a maximum, and solve for that position in the same way as above.

Where the mass to be accelerated is considerable the maximum effort will be called for at the beginning of each stroke. If there is a quick return the maximum effort will come at the beginning of the return stroke. A planer calls for about twice as much power at the beginning of its stroke return as it does during its cutting stroke.

45. Force Problems, Continued.—In the usual type of steam-engine the slider-crank mechanism is used, but energy is supplied to the slider (which represents piston, piston-rod, and cross-head), and the resistance opposes the rotation of the crank and attached shaft. In any position of the mechanism (Fig. 41), force applied to the crank-pin through the connecting-rod may be resolved into two components, one radial and one tangential. The tangential component tends to produce rotation; the radial component produces pressure between the surfaces of the shaft-journal and its bearing. The tangential component is approximately a maximum when the angle between crank and connecting-rod equals 90° ,* and it becomes zero when C reaches A or B . If there is a uniform resistance the rate of doing work is constant. Hence, since the energy is supplied at a varying rate, it follows that during part of the revolution the effort is greater than the resistance; while during the remaining portion of the revolution the effort is less than the resistance, and the machine will stop

* See foot-note on page 52.

unless other means are provided to maintain motion. A "fly-wheel" is keyed to the shaft, and this wheel, because of slight

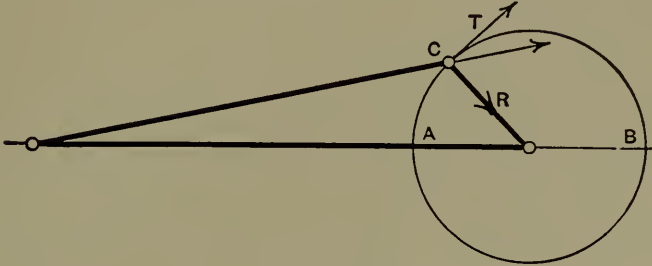

FIG. 41.

variations of velocity, alternately stores and gives out the excess and deficiency of energy of the effort, thereby adapting it to the constant work to be done.*

46. Problem.—Given length of stroke of the slider of a steam-engine slider-crank mechanism, the required horse-power, or rate of doing work, and number of revolutions. Required the total *mean* pressure that must be applied to the piston.

Let L = length of stroke = 1 foot;

HP = horse-power = 20;

N = strokes per minute = 200;

F = required mean force on piston.

Then $N \times L = 200$ feet per minute = mean velocity of slider = V .

Now, the mean rate of doing work in the cylinder and at the main shaft during each stroke is the same (friction neglected); hence $FV = HP \times 33000$,

$$F = \frac{HP \times 33000}{V} = \frac{20 \times 33000}{200} = 3300 \text{ lbs.}$$

47. Solution of Force Problem in the Slider-crank Chain.

—In the slider-crank chain the velocity of the slider necessarily

* See Chapter XVI, page 244.

varies from zero at the ends of its stroke to a maximum value near mid-stroke. The mass of the slider and attached parts is therefore positively and negatively accelerated each stroke. When a mass is positively accelerated it stores energy; and when it is negatively accelerated it gives out energy. The amount of this energy, stored or given out, depends upon the mass and the acceleration. The slider stores energy during the first part of its stroke and gives it out during the second part of its stroke.

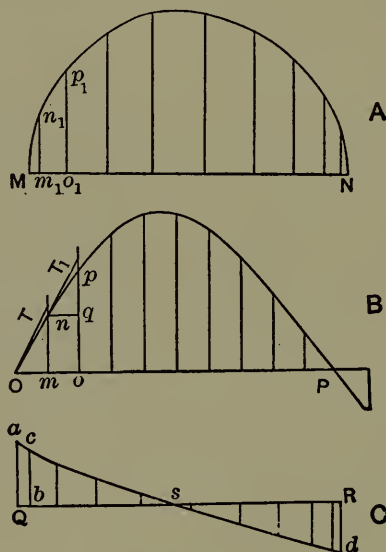

FIG. 42.

While, therefore, it gives out all the energy it receives, it gives it out differently distributed. In order to find exactly how the energy is distributed, it is necessary to find the acceleration throughout the slider's stroke. This may be done as follows: Fig. 42, *A*, shows the velocity diagram of the slider of a slider-crank mechanism for the forward stroke, the ordinates representing velocities, the corresponding abscissæ representing the slider positions. The acceleration required at any point $= \frac{\Delta v}{\Delta t}$, in which Δv is the increase in velocity during any interval of time Δt , assuming that the increase in velocity becomes constant

at that point. Lay off the horizontal line $OP = MN$. Divide OP into as many *equal* parts as there are *unequal* parts in MN . These divisions may each represent Δt . At m erect the ordinate $mn = m_1n_1$, and at o erect the ordinate $op = o_1p_1$. Continue this construction throughout OP , and draw a curve through the upper extremities of the ordinates. Fig. 42, B , is a velocity diagram on a "time base." At O draw the tangent OT to the curve. If the increase in velocity were uniform during the time interval represented by Om , the increment of velocity would be represented by mT . Therefore mT is proportional to the acceleration at the point O , and may be laid off as an ordinate of an acceleration diagram (Fig. 42C). Thus $Qa = mT$. The divisions of QR are the same as those of MN ; *i.e.*, they represent *positions* of the slider. This construction may be repeated for the other divisions of the curve B . Thus at n the tangent nT_1 and horizontal nq are drawn, and qT_1 is proportional to the acceleration at n , and is laid off as an ordinate bc of the acceleration diagram. To find the value in acceleration units of Qa , mT is read off in velocity units $= \Delta v$ by the scale of ordinates of the velocity diagram. This value is divided by Δt , the time increment corresponding to Om . The result of this division $\frac{\Delta v}{\Delta t} = \text{acceleration at } M \text{ in acceleration units.}$

$\Delta t =$ the time of one stroke, or of one half revolution of the crank divided by the number of divisions in OP . If the linear velocity of the center of the crank-pin in feet per second, $= v$, be represented by the length of the crank radius $= \frac{MN}{2} = a$, then the scale of velocities, or velocity in feet per second for 1 inch of ordinate,

$$= \frac{v}{a} = \frac{\pi DN}{a60}.$$

D is the actual diameter of the crank circle, N is the number of revolutions per minute, and a is the crank radius measured on the figure.

The determination of the acceleration curve, by means of tangents drawn to the "time-base" velocity curve, has a serious drawback. The tangent lines are laid down by inspection, and slight inaccuracy in their location and construction may lead to considerable errors in the ordinates obtained for the acceleration curve.

The following method is therefore suggested as an alternative.

If one point is rotating about another point with a given instantaneous velocity $=v$ and a radius $=r$, the instantaneous radial acceleration of either point toward the other $=\frac{v^2}{r}$.

Consider the slider-crank chain in the position at the beginning of the forward stroke as shown in Fig. 43A. The problem is to determine the acceleration of the point bc toward ad . Accelerations toward the right will be considered as positive, toward the left as negative. In the position chosen the point ab is moving, relatively to both links d and c , in the direction of the arrow with a velocity $=v$, the uniform velocity of ab relatively to d .

The acceleration of bc toward ad is always made up of two components, namely, the acceleration of bc toward ab and the acceleration of ab toward ad . In the position under considera-

tion the acceleration of bc toward $ab = \frac{v^2}{b}$ in a positive direction.

Similarly the acceleration of ab toward $ad = \frac{v^2}{a}$ in a positive direction. The total acceleration of bc toward ad therefore equals

the sum of these two components, or $=\frac{v^2}{b} + \frac{v^2}{a}$.

On the other hand, at the end of the forward stroke, shown in Fig. 43B, the acceleration of bc toward $ab = \frac{v^2}{b}$ in a positive

direction as before, while the acceleration of ab toward $ad = \frac{v^2}{a}$ in a *negative* direction. The algebraic sum of these two com-

ponents therefore $= \frac{v^2}{b} - \frac{v^2}{a}$. This quantity will always have a negative value, since in the slider-crank mechanism a must always be smaller than b .

To construct the acceleration curve, lay off a length MN

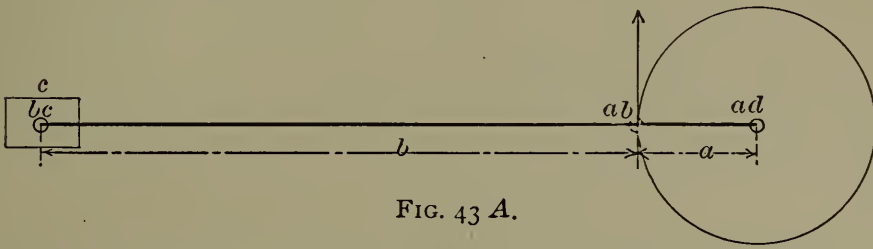

FIG. 43 A.

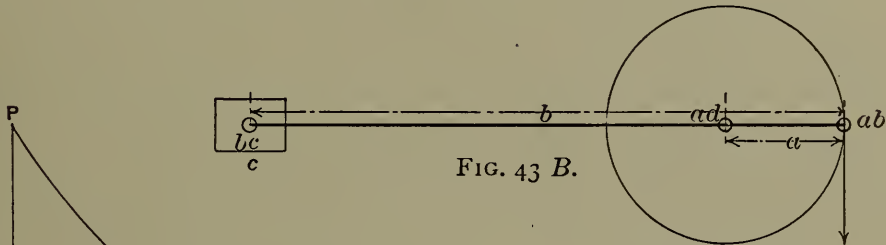

FIG. 43 B.

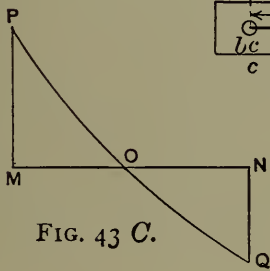

FIG. 43 C.

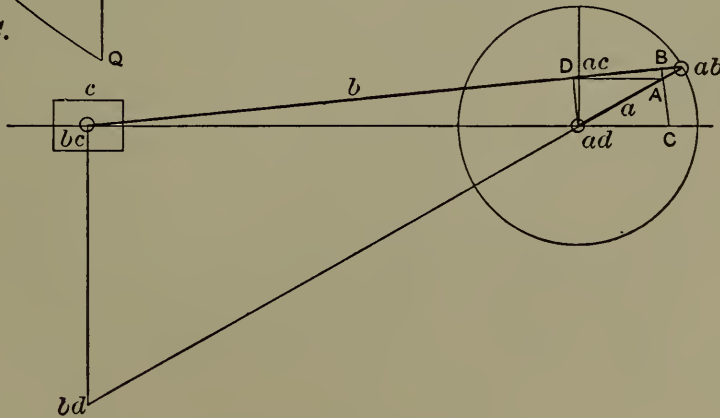

FIG. 44.

(Fig. 43C) proportionate to the length of the stroke of the slider. At M erect an ordinate, MP , whose value equals $\frac{v^2}{b} + \frac{v^2}{a}$. It is best to use for these ordinates a scale on which a (the length

of the crank) represents the value $\frac{v^2}{a}$. At N erect the negative ordinate $NQ = \frac{v^2}{b} - \frac{v^2}{a}$.

There is a position of the slider, O , where the acceleration equals zero. This must correspond to the position of the slider when it has its maximum velocity, which may be taken from the original velocity diagram of the slider, or, with greater accuracy, from Curve B in the Appendix. Through POQ draw a smooth curve. For most purposes this curve will be accurate enough.

Where more points of the curve are desired for the sake of greater accuracy the method illustrated in Fig. 44 may be used. Assume the slider in the position at which its acceleration is desired and draw the crank a and connecting-rod b in their corresponding positions. Locate the centros ad , ab , ac , and bd . From a draw a parallel to $bc-ad$ until it cuts the crank, prolonged if necessary, at A . From A draw a parallel to $ad-ac$ until it cuts the connecting-rod at B . From B draw a perpendicular to the connecting-rod until it cuts $bc-ad$, prolonged if necessary, at C . Then $ad-C$ is the desired ordinate of the acceleration diagram on the scale by which the length $a = \frac{v^2}{a}$.

The proof is as follows, reference being made to Fig. 44.

At this instant every point of b relatively to c is swinging about the centro bc with a velocity proportional to its distance from bc .

$$\frac{\text{vel. of } bd \text{ rel. to } c}{\text{vel. of } ab \text{ rel. to } c} = \frac{bd-bc}{ab-bc} = \frac{ac-ad}{ac-ab}$$

But $ac-ad$ represents the velocity of c relatively to d (or d relatively to c) on the same scale that $ad-ab$ represents the velocity of the point ab relatively to d . Therefore $ac-ab$ repre-

sents the velocity of ab rotating about bc relatively to c on the same scale that $ad-ab$ represents the velocity of ab relatively to d .

Hence the radial acceleration of ab toward bc * (or conversely of bc toward ab) = $\frac{\overline{ab-ac}^2}{b}$, which is represented by the length

$ab-B$, as can be shown as follows:

By similar triangles

$$\frac{ab-B}{ab-ac} = \frac{ab-A}{ab-ad} = \frac{ab-ac}{ab-bc}$$

$$\therefore ba-B = \frac{\overline{ab-ac}^2}{ab-bc} = \frac{\overline{ab-ac}^2}{b}$$

The radial acceleration of ab toward $ad = \frac{\overline{ab-ad}^2}{a}$, whose value we represent by the length a . The component of this acceleration in the direction $bc-ab = ab-D$.

The acceleration of bc , relatively to d , along the path $bc-ab$ is made up of two components: 1st, the acceleration of bc toward $ab (= B-ab)$ plus, 2d, the acceleration of ab relatively to d along the same path ($= ab-D$).

In the position shown this algebraic sum is the negative quantity represented by $B-D$. But the actual direction of bc 's acceleration relatively to d is along the line $bc-ad$. Its acceleration in this direction must therefore be the quantity whose component along $ab-bc$ is $B-D$, namely, $C-ad$. Q.E.D.

If the weight W of parts accelerated is known, the force F necessary to produce the acceleration at any slider position may be found from the fundamental formula of mechanics,

$$F = M \dot{p} = \frac{W \dot{p}}{g},$$

* The acceleration of a point A with respect to another point B is the acceleration of A with respect to a non-rotating body of which B is a point.

p being the acceleration corresponding to the position considered. If the ordinates of the acceleration diagram are taken as representing the *forces* which produce the acceleration, the diagram will have force ordinates and space abscissæ, and areas will represent work. Thus, Qas , Fig. 42C, represents the work stored during acceleration, and Rsd represents the work given out during retardation. Let MN , Fig. 45, represent the length of the slider's stroke and NC the resistance of cutting (uniform) on the same force scale as that by which Qa , Fig. 42C, represents the

force $\frac{Wp}{g}$ at the beginning of the stroke; then energy to do cutting per stroke is represented by the area $MBCN$. But during the early part of the stroke the reciprocating parts must be accelerated, and the force necessary at the beginning, found as above, $=BD=Qa$. The driving-gear must, therefore, be able to overcome resistance equal to $MB+BD$. The acceleration, and hence the accelerating force, decreases as the slider advances, becoming zero at E . From E on the acceleration becomes negative, and hence the slider gives out energy and helps to overcome the resistance, and the driving-gear has only to furnish energy represented

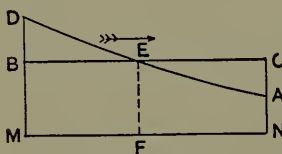

FIG. 45.

by the area $AEFN$, though the work really done against resistance equals that represented by the area $CEFN$. The energy represented by the difference of these areas, $=ACE$, is that which is stored in the slider's mass during acceleration. Since by the law of conservation of energy, energy given out per cycle = that received, it follows that area $ACE = \text{area } DEB$, and area $BCM N = ADMN$. This redistribution of energy would seem to modify the problem on page 52, since that problem is based on the assumption of uniform resistance during cutting stroke. The position of maximum velocity of slider, however, corresponds to acceleration $=0$. The maximum rate of doing work, and the

corresponding torsional driving moment at the crank-shaft would probably correspond to the same position, and would not be materially changed. In such machines as shapers, the acceleration and weight of slider are so small that the redistribution of energy is unimportant.

48. Solution of the Force Problem in the Steam-engine Slider-crank Mechanism. (Slider represents piston with its rod, and the cross-head.)—The steam acts upon the piston with a pressure which varies during the stroke. The pressure is redistributed before reaching the cross-head pin, because the reciprocating parts are accelerated in the first part of the stroke, with accompanying storing of energy and reduction of pressure on the cross-head pin; and retarded in the second part of the stroke, with accompanying giving out of energy and increase of pressure on the cross-head pin. Let the ordinates of the full line diagram above OX , Fig. 46*A*, represent the total effective pressure on the piston throughout a stroke. Fig. 46*B* is the velocity diagram of slider.

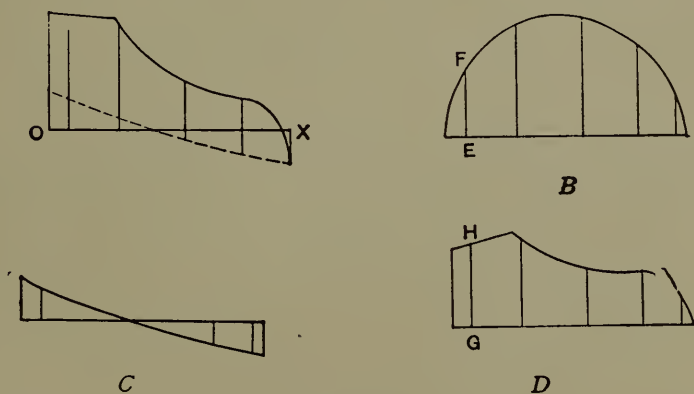

FIG. 46.

Find the acceleration throughout stroke, and from this and the known value of weight of slider find the force due to acceleration. Draw diagram Fig. 46*C*, whose ordinates represent the force due to acceleration, upon the same force scale used in *A*. Lay off this diagram on OX as a base line, thereby locating the dotted line. The vertical ordinates between this dotted line and the

upper line of A represent the pressure applied to the cross-head pin. These ordinates may be laid off from a horizontal base line, giving D . The product of the values of the corresponding ordinates of B and D = the *rate of doing work throughout the stroke*. Thus the value of GH in pounds \times value of EF in feet per second = the rate of doing work in foot-pounds per second upon the cross-head pin, when the center of the cross-head pin is at E . The rate of doing work at the crank-pin is the same as at the cross-head pin. Hence dividing this rate of doing work, $=EF \times GH$, by the constant tangential velocity of the crank-pin center, gives the force acting tangentially on the crank-pin to produce rotation. The tangential forces acting throughout a half revolution of the crank may be thus found, and plotted upon a horizontal base line = length of half the crank circle (Fig. 47*B*). The work done upon the piston, cross-head pin, and crank during a piston stroke is the same. Hence the areas of A and D , Fig. 46, are equal to each other, and to the area of the diagram, Fig. 47*B*. The forces acting along the connecting-rod for all positions during the piston stroke may be found by drawing force triangles with one side horizontal, one vertical, and one parallel to position of connecting-rod axis, the horizontal side being equal to the corresponding ordinate of Fig. 46*D*. The vertical sides of these triangles will represent the guide reaction, while the side parallel to the connecting-rod axis represents the force transmitted by the connecting-rod.

The tangential forces acting on the crank-pin may be found graphically by the method shown in Fig. 47*A*. Let GH represent the net effective force acting in a horizontal direction at the center of the cross-head pin.

It has been shown that EF represents the velocity of the slider on the same scale that EA represents that of the center of the crank-pin; also that the rate of doing work, after having made the necessary corrections for acceleration, is the same at

the center of the crank-pin as at the slider, *i.e.*, $GH \times EF = \text{tangential force at center of crank-pin} \times EA$. Hence the tangential force at center of crank-pin $= GH \times \frac{EF}{EA}$.

Lay off $AB = GH$, and draw BC parallel to EF . Then, by similar triangles,

$$\frac{BC}{AB} = \frac{EF}{EA}; \therefore BC = AB \frac{EF}{EA} = GH \frac{EF}{EA} =$$

the tangential force acting at the crank-pin center for the assumed position of the mechanism, on the same scale as $GH = \text{net effective horizontal force on slider}$.

Lay off $AD = BC$.

Following through this construction for a number of positions of the mechanisms, a polar diagram is determined which shows

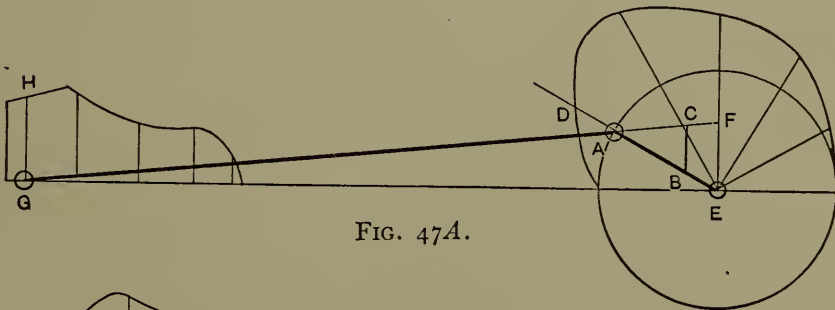

FIG. 47A.

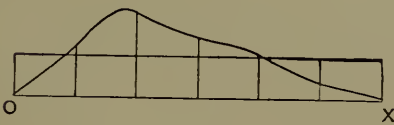

FIG. 47B.

very clearly the relation existing between the varying tangential forces and the corresponding crank positions. Before this diagram may be used in the solution of the fly-wheel problem (see Chapter XVI) it should be transferred to a straight-line base

whose length for one stroke equals the semi-circumference of the crank-pin circle. That is, the abscissæ will be the distance moved through by the center of the crank-pin and the ordinates will be the corresponding radial intercepts AD . The diagram so obtained will be identical with that shown in Fig. 47*B*.

CHAPTER VI.

PROPORTIONS OF MACHINE PARTS AS DICTATED BY STRESS.

49. The size and form of machine parts * are governed by five main considerations:

(1) The size and nature of the work to be accommodated (as the swing of engine-lathes, etc.).

(2) The stresses which they have to endure.

(3) The maintaining of truth and accuracy against wear, including all questions of lubrication.

(4) The cost of production.

(5) Appearance.

The first is a given condition in any problem; the second will be discussed here; the third will be treated in the chapters on Journals and Sliding Surfaces; the fourth is touched upon here; the principles governing the fifth are treated in Chapter XIX and here.

It is assumed in this and following chapters that the reader is familiar with the properties of the materials employed in machine construction,† and with the general principles of the science of mechanics.

50. The stresses acting on machine parts may be constant, variable, or suddenly applied.

* On this general subject see an excellent article by Prof. Sweet in the Journal of the Franklin Institute, 3d Series, Vol. 125, pp. 278-300. The reader is also referred to "A Manual of Machine Construction," by Mr. John Richards, and to the Introduction of this volume.

† See Smith's "Materials of Machines."

A CONSTANT stress is frequently spoken of as a STEADY, or DEAD, LOAD.

A VARIABLE stress is known as a LIVE LOAD.

A SUDDENLY APPLIED stress is known as a SHOCK.

51. Constant Stress.—If a machine part is subjected to a constant stress, *i.e.*, an unvarying load constantly applied, its design becomes a simple matter, as the amount of such a stress can generally be very closely estimated. Knowing this and the properties of the materials to be used, it is only necessary to calculate the area which will sustain the load without excessive deformation.

Thus, in simple tension or compression, if we let U = the ultimate strength of the material in pounds per square inch, F the total constant stress in pounds, A the unknown area in square inches necessary to sustain F , we write

$$A = \frac{F}{U \div K},$$

where K is a so-called FACTOR OF SAFETY, introduced to reduce the permitted unit stress to such a point as will limit the deformation (strain) to an allowable amount, and also to provide for possible defects in the material itself. In exceptional cases where the stresses permit of accurate calculation, and the material is of proven high grade and positively known strength, K has been given as low a value as $1\frac{1}{2}$; but values of 2 and 3 are ordinarily used for wrought iron and steel free from welds; while 4 to 5 are as small as should be used for cast iron, on account of the uncertainty of its composition, the danger of sponginess of structure, and indeterminate shrinkage stresses.

The SAFE UNIT STRESS = $f = \frac{U}{K}$ in pounds per square inch.

52. Variable Stress.—We pass next to the consideration of

variable stresses or live loads. Here the problem is much more complex than with dead loads.

Experiments by Wöhler,* and Bauschinger,† with the work of Weyrauch ‡ and others have given us the laws of bodies subjected to repeated stresses. In substance Wöhler's law is as follows: MATERIAL MAY BE BROKEN BY REPEATED APPLICATIONS OF A FORCE WHICH WOULD BE INSUFFICIENT TO PRODUCE RUPTURE BY A SINGLE APPLICATION. THE BREAKING IS A FUNCTION OF RANGE OF STRESS; AND AS THE VALUE OF THE RECURRING STRESS INCREASES, THE RANGE NECESSARY TO PRODUCE RUPTURE DECREASES. IF THE STRESS BE REVERSED, THE RANGE EQUALS THE SUM OF THE POSITIVE AND NEGATIVE STRESS.

Bauschinger's conclusions were as follows:

(1) WITH REPEATED TENSILE STRESSES WHOSE LOWER LIMIT WAS ZERO, AND WHOSE UPPER LIMIT WAS NEAR THE ORIGINAL ELASTIC LIMIT, RUPTURE DID NOT OCCUR WITH FROM 5 TO 16 MILLION REPETITIONS. He cautions the designer (*a*) that this will not hold for DEFECTIVE material, *i.e.*, a factor of safety must still be used for this reason; and (*b*) that the elastic limit of the material must be carefully determined, because it may have been artificially raised by cold working, in which case it does not accurately represent the material. The original elastic limit may be determined by testing a piece of the material after careful annealing.

(2) WITH OFTEN-REPEATED STRESSES VARYING BETWEEN ZERO AND AN UPPER STRESS WHICH IS IN THE NEIGHBORHOOD OF OR ABOVE THE ELASTIC LIMIT, THE LATTER IS RAISED EVEN ABOVE, OFTEN FAR ABOVE, THE UPPER LIMIT OF STRESS, AND IT IS RAISED HIGHER AS THE NUMBER OF REPETITIONS OF STRESS INCREASES,

* "Ueber die Festigkeitsversuche mit Eisen und Stahl," A. Wöhler, Berlin, 1870.

† "Mittheilungen der König. Tech. Hochschule zu München," J. Bauschinger, Munich, 1886 and 1897.

‡ "Structures of Iron and Steel," by J. Weyrauch. Trans. by A. J. DuBois, New York, 1877

WITHOUT, HOWEVER, A KNOWN LIMITING VALUE, L , BEING EXCEEDED.

(3) REPEATED STRESSES BETWEEN ZERO AND AN UPPER LIMIT BELOW L DO NOT CAUSE RUPTURE; BUT IF THE UPPER LIMIT IS ABOVE L RUPTURE WILL OCCUR AFTER A LIMITING NUMBER OF REPETITIONS.

From this it will be seen that keeping within the ORIGINAL ELASTIC LIMIT insures safety against rupture from repeated stress if the stress is not reversed; and that, when the stress is reversed, the total range should not exceed the ORIGINAL ELASTIC RANGE of the material.

Various formulæ have been proposed by different authorities embodying the foregoing laws.

Unwin's is here given as being most simple and general:

Let U be the breaking strength of the material in pounds per square inch for a load once gradually applied.

Let f max. be the breaking strength in pounds per square inch for the same material subjected to a variable load ranging between the limits f max. and f min., and repeated an indefinitely great number of times. f min. is + if the stress is of the same kind as f max., and is - if the stress is of the opposite kind, and it is supposed that f min. is not greater than f max. Then the range of stress is $\Delta = f$ max. \mp f min., the upper sign being taken if the stresses are of the same kind and the lower if they are different. Hence Δ is always positive. The formula * is

$$f \text{ max.} = \frac{\Delta}{2} + \sqrt{U^2 - \eta \Delta U},$$

where η is a variable coefficient whose value has been experimentally determined. For ductile iron and steel $\eta = 1.5$, increasing with hardness of the material to a value of 2.

* Unwin's "Machine Design," Vol. 1, 14th ed., pp. 31-33.

This formula is of general application.

Three cases may be considered:

(1) A constant stress, or dead load. In this case the range of stress, $\Delta = 0$, and consequently $f \text{ max.} = U$, as it should be.

(2) The stress is variable between an upper limit and zero, but is not reversed.

Here $\Delta = f \text{ max.}$, since $f \text{ min.} = 0$, and consequently $f \text{ max.} = 2(\sqrt{\eta^2 + 1} - \eta)U$.

(3) The stress is reversed, being alternately a compressive and tensile stress of the same magnitude.

Here $f \text{ min.} = -f \text{ max.}$ and $\Delta = 2f \text{ max.}$

$$\therefore f \text{ max.} = \frac{1}{2\eta}U.$$

In each case it is necessary to divide the breaking load, $f \text{ max.}$, by a factor of safety in order to get the safe unit stress f , *i.e.*, $f = \frac{f \text{ max.}}{K}$. K is a factor of safety whose numerical value depends upon the material used. (See Sec. 51.)

53. Problem.—Consider that there are three pieces to be designed using machinery steel having an ultimate tensile strength of 60,000 lbs. per square inch.

The first piece sustains a steady load having a dead weight suspended from it.

The second piece is a member of a structure which is alternately loaded and unloaded without shock.

The third piece is subjected to alternate stresses without shock.

In each case the maximum load is the same, being 30,000 lbs. $= F$. This material is generally reliable and uniform in quality. A factor of safety of 3 is common; $\therefore K = 3$ in each case; $\eta = 1.5$.

CASE I.

$$f \text{ max.} = U \quad \text{and} \quad f = \frac{f \text{ max.}}{3}.$$

$$\therefore f = \frac{U}{3} = \frac{60000}{3} = 20,000 \text{ lbs. per sq. in.}$$

The necessary area A to sustain F is determined by the equation

$$A = \frac{F}{f} = \frac{30000}{20000} = 1\frac{1}{2} \text{ sq. in.}$$

CASE II.

$$f \text{ max.} = 2(\sqrt{\eta^2 + 1} - \eta)U.$$

$$\eta = 1.5 \quad \text{and} \quad U = 60,000 \text{ lbs. per sq. in.}$$

$$\therefore f \text{ max.} = .6054U = 36,324 \text{ lbs. per sq. in.}$$

$$f = \frac{f \text{ max.}}{3} = 12,108 \text{ lbs. per sq. in.}$$

$$A = \frac{F}{f} = \frac{30000}{12108} = 2\frac{1}{2} \text{ sq. in., nearly.}$$

CASE III.

$$f \text{ max.} = \frac{1}{2\eta}U.$$

$$\therefore f \text{ max.} = \frac{60000}{3} = 20,000 \text{ lbs. per sq. in.}$$

$$f = \frac{f \text{ max.}}{3} = 6667 \text{ lbs. per sq. in.}$$

$$A = \frac{F}{f} = \frac{30000}{6667} = 4\frac{1}{2} \text{ sq. in.}$$

The importance of considering the question of range of stress in designing is brought home by this illustration. Comparison

of results shows that WITH THE SAME MAXIMUM LOAD in each case, the second piece must be given nearly twice the area of the first, while the third must be three times as great in area as the first, the only difference in the three cases being the range of stress.

54. Shock.—Consideration of the design of parts subjected to shocks or suddenly applied loads.

(1) A load is applied on an unstrained member in a single instant, but without velocity.

In this case, if the stress does not exceed the limit of elasticity of the material, the stress produced will be just twice that produced by a gradually applied load of the same magnitude. If F = maximum total load as before, then the maximum total stress = $2F$. The design of the member is then made as in Case II or Case III of the preceding section.

(2) A load is applied on an unstrained member in a single instant, but with velocity.

In this case the stress on the member will exceed that due to a gradually applied load of the same magnitude by an amount depending on the energy possessed by the load at the moment of impingement.

Assume that a member is stressed by a load F falling through a height h . The unknown area of the member = A , and the allowable strain (*i.e.*, extension or compression) = λ . As before, f = allowable unit stress (determined by the question of range by the use of Unwin's formula).

The energy of the falling load is

$$F(h + \lambda).$$

The work done in straining the member an amount λ with a maximum fiber stress f is $\frac{f}{2}\lambda A$, provided the elastic limit is

not exceeded. Equating these values of energy expended and work done and solving for A gives $A = \frac{2F(h+\lambda)}{j\lambda}$.

55. Form Dictated by Stress. Tension.—Suppose that A and B , Fig. 48, are two surfaces in a machine to be joined by a member

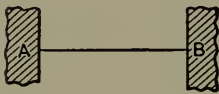

FIG. 48.

subjected to simple tension. What is the proper form for the member? The stress in all sections of the member at right angles to the line of application, AB , of the force will be the same.

Therefore the areas of all such sections should be equal; hence the outlines of the members should be straight lines parallel to AB . The distance of the material from the axis AB has no effect on its ability to resist tension. Therefore there is nothing in the character of the stress that indicates the form of the cross-section of the member. The form most cheaply produced, both in the rolling-mill and the machine-shop, is the cylindrical form. Economy, therefore, dictates the circular cross-section. After the required area necessary for safely resisting the stress is determined, it is only necessary to find the corresponding diameter, and it will be the diameter of all sections of the required member if they are made circular. Sometimes in order to get a more harmonious design, it is necessary to make the tension member just considered of rectangular cross-section, and this is allowable although it almost always costs more. The thin, wide rectangular section should be avoided, however, because of the difficulty of insuring a uniform distribution of stress. A unit stress might result from this at one edge greater than the strength of the material, and the piece would yield by tearing, although the AVERAGE stress might not have exceeded a safe value.

56. Compression.—If the stress be compression instead of tension, the same considerations dictate its form as long as it is a "short block," *i.e.*, as long as the ratio of length to lateral dimensions is such that it is sure to yield by crushing instead of

by "buckling." A short block, therefore, should have its longitudinal outlines parallel to its axis, and its cross-section may be of any form that economy or appearance may dictate. Care should be taken, however, that the *least* lateral dimension of the member be not made so small that it is thereby converted into a "long column."

If the ratio of longitudinal to lateral dimensions is such that the member becomes a "long column," the conditions that dictate the form are changed, because it would yield by buckling or flexure instead of crushing. The strength and stiffness of a long column are proportional to the moment of inertia of the cross-section about a gravity axis at right angles to the plane in which the flexure occurs. A long column with "fixed" or "rounded" ends has a tendency to yield by buckling which is equal in all directions. Therefore the moment of inertia needs to be the same about all gravity axes, and this of course points to a circular section. Also the moment of inertia should be as large as possible for a given weight of material, and this points to the hollow section. The disposition of the metal in a circular hollow section is the most economical one for long-column machine members with fixed or rounded ends. This form, like that for tension, may be changed to the rectangular hollow section if appearance requires such change. If the long-column machine member be "pin connected," the tendency to buckle is greatest in a plane through the line of direction of the compressive force and at right angles to the axis of the pins. The moment of inertia of the cross-section should therefore be greatest about a gravity axis parallel to the axis of the pins. Example, a steam-engine connecting-rod.

57. Flexure.—When the machine member is subjected to transverse stress the best form of cross-section is probably the I section, *a*, Fig. 49, in which a relatively large moment of inertia, with economy of material, is obtained by putting the excess of

the material where it is most effective to resist flexure, *i.e.*, at the greatest distance from the given gravity axis. Sometimes, however, if the I section has to be produced by cutting away the material at *e* and *d*, in the machine-shop, instead of producing the form directly in the rolls, it is cheaper to use the solid rectangular section *c*. If the member subjected to transverse stress is for any reason made of cast material, as is often the case, the form *b* is preferable for the following reasons:

(1) The best material is almost sure to be in the thinnest part of a casting, and therefore in this case at *f* and *g*, where it is most effective to resist flexure.

(2) The pattern for the form *b* is more cheaply produced and maintained than that for *a*.

(3) If the surface is left without finishing from the mold, any imperfections due to the foundry work are more easily corrected in *b* than in *a*.

Machine members subjected to transverse stress, which continually change their position relatively to the force which produces the flexure, should have the same moment of inertia about all gravity axes, as, for instance, rotating shafts that are strained transversely by the force due to the weight of a fly-wheel, or that due to the tension of a driving-belt. The best form of cross-section in this case is circular. The hollow section would give the greatest economy of material, but hollow members are expensive to produce in wrought material, such as is almost invariably used for shafts. The hollow circular section is meeting with increasing use, especially for large shafts, on account of the combined lightness and strength.

58. Torsion.—Torsional strength and stiffness are proportional to the polar moment of inertia of the cross-section of the member. This is equal to the sum of the moments of inertia about two gravity axes at right angles to each other. The forms in Fig. 49 are therefore not correct forms for the resistance of

torsion. The circular solid or hollow section, or the rectangular solid or hollow section, should be used.

The I section, Fig. 50, is a correct form for resisting the stress P , applied as shown. Suppose the web C to be divided on the line CD , and the parts to be moved out so that they occupy the positions shown at a and b . The form thus obtained is called a "box section." By making this change the moment of inertia about ab has not been changed, and therefore the new form is just as effective to resist flexure due to the force P as it was before the change. The box section is better able to

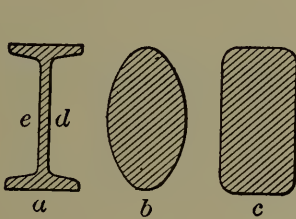

FIG. 49.

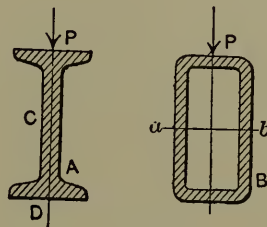

FIG. 50.

resist torsional stress, because the change made to convert the I section into the box section has increased the polar moment of inertia. The two forms are equally good to resist tensile and compressive force if they are sections of short blocks. But if they are both sections of long columns, the box section would be preferable, because the moments of inertia would be more nearly the same about all gravity axes.

59. Machine Frames.—The framing of machines almost always sustains combined stresses, and if the combination of stresses include torsion, flexure in different planes, or long-column compression, the box section is the best form. In fact, the box section is by far the best form for the resisting of stress in machine frames. There are other reasons, too, besides the resisting of stress that favor its use.*

* See Richard's "Manual of Machine Construction."

(1) Its appearance is far finer, giving an idea of completeness that is always wanting in the ribbed frames.

(2) The faces of a box frame are always available for the attachment of auxiliary parts without interfering with the perfection of the design.

(3) The strength can always be increased by decreasing the size of the core, without changing the external appearance of the frame, and therefore without any work whatever on the pattern itself.

The cost of patterns for the two forms is probably not very different, the pattern itself being more expensive in the ribbed form, and the necessary core-boxes adding to the expense in the case of the box form. The expense of production in the foundry, however, is greater for the box form than for the ribbed form, because core work is more expensive than "green-sand" work. The balance of advantage is very greatly in favor of box forms, and this is now recognized in the practice of the best designers of machinery.

To illustrate the application of the box form to machine members, let the table of a planer be considered. The cross-section is almost universally of the form shown in Fig. 51. This is evidently a form that would yield easily to a force tending to



FIG. 51.

twist it, or to a force acting in a vertical plane tending to bend it. Such forces may be brought upon it by "strapping down work," or by the support of heavy pieces upon centers. Thus in Fig. 52 the heavy piece *E* is supported between the centers. For proper support the centers need to be screwed in with a considerable force. This causes a reaction tending to separate the centers and to bend the table between *C* and *D*. As a result of this the *V*'s

on the table no longer have a bearing throughout the entire surface of the guides on the bed, but only touch near the ends, the pressure is concentrated upon small surfaces, the lubricant is squeezed out, the V's and guides are "cut," and the planer is

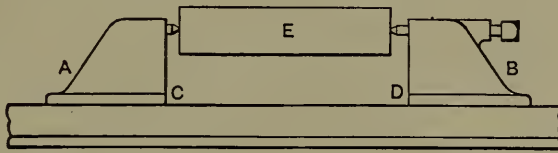

FIG. 52.



FIG. 53.

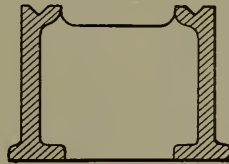

FIG. 54.

rendered incapable of doing accurate work. If a table were made of the box form shown in Fig. 53, with partitions at intervals throughout its length, it would be far more capable of maintaining its accuracy of form under all kinds of stress, and would be more satisfactory for the purpose for which it is designed.*

The bed of a planer is usually in the form shown in section in Fig. 54, the side members being connected by "cross-girts" at intervals. This is evidently not the best form to resist flexure and torsion, and a planer-bed may be subjected to both, either by reason of improper support or because of changes in the form of foundation. If the bed were of box section with cross partitions, it would sustain greater stress without undue yielding. Holes could be left in the top and bottom to admit of supporting the core in the mold, to serve for the removal of the core sand, and to render accessible the gearing and other mechanism inside of the bed.

* Professor Sweet has designed and constructed such a table for a large milling-machine.

This same reasoning applies to lathe-beds. They are strained transversely by force tending to separate the centers, as in the case of "chucking"; torsionally by the reaction of a tool cutting the surface of a piece of large diameter; and both torsion and flexure may result, as in the case of the planer-bed, from an improperly designed or yielding foundation. The box form would be the best possible form for a lathe-bed; some difficulties in adaptation, however, have prevented its extended use as yet.

These examples illustrate principles that are of very broad application in the designing of machines.

60. Brackets.—Often in machines there is a part that projects either vertically or horizontally and sustains a transverse

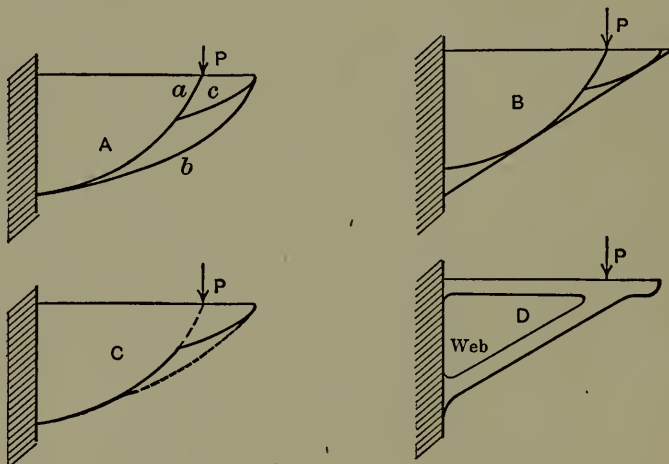

FIG. 55.

stress; it is a cantilever, in fact. If only transverse stress is sustained, and the thickness is uniform, the outline for economy of material is parabolic. In such a case, however, the outline curve of the member should start from the point of application of the force, and not from the extreme end of the member, as in the latter case there would be an excess of material. Thus in *A*, Fig. 55, *P* is the extreme position at which the force can be ap-

plied. The parabolic curve *a* is drawn from the point of application of *P*. The end of the member is supported by the auxiliary curve *c*. The curve *b* drawn from the end gives an excess of material. The curves *a* and *c* may be replaced by a single continuous curve as in *C*, or a tangent may be drawn to *a* at its middle point as in *B*, and this straight line used for the outline, the excess of material being slight in both cases. Most of the machine members of this kind, however, are subjected also to other stresses. Thus the " housings " of planers have to resist torsion and side flexure. They are very often supported by two members of parabolic outline; and to insure the resistance of the torsion and side flexure, these two members are connected at their parabolic edges by a web of metal that really converts it into a box form. Machine members of this kind may also be supported by a brace, as in *D*. The brace is a compression member and may be stiffened against buckling by a " web " as shown, or by an auxiliary brace.

61. Other Considerations Governing Form.—One consideration governing the form of machine parts has been touched upon in the preceding sections. It may be well to state it here as a general principle: Other considerations being equal the form of a member should be that which can be most cheaply produced both as regards economy of material and labor

Another element enters into the form of cast members. Castings, unless of the most simple form, are almost invariably subjected to indeterminate shrinkage stresses. Some of these are undoubtedly due to faulty work on the part of the molder, others are induced by the very form which is given the piece by the designer. They cannot be eliminated entirely, but the danger can be minimized by paying attention to these general laws:

(*a*) Avoid all sharp corners and re-entrant angles.

(*b*) All parts of all cross-sections of the member should be as nearly of the same thickness as possible.

(c) If it is necessary to have thick and thin parts in the same casting, the change of form from one to the other should be as gradual as possible.

(d) Castings should be made as thin as is consistent with considerations of strength, stiffness, and resistance to vibration.

CHAPTER VII.

RIVETED JOINTS.

62. **Methods of Riveting.**—A rivet is a fastening used to unite metal plates or rolled structural forms, as in boilers, tanks, built-up machine frames, etc. It consists of a head, *A*, Fig. 56, and a straight shank, *B*. It is inserted, usually red-hot, into holes, either drilled or punched in the parts to be connected, and the projecting end of the shank is then formed into a head (see dotted lines) either by hand- or machine-riveting. A rivet is a permanent fastening and can only be removed by cutting off the head. A row of rivets joining two members is called a **RIVETED JOINT** or **SEAM OF RIVETS**. In hand-riveting the projecting end of the shank is struck a quick succession of blows with hand hammers and formed into a head by the workman. A helper holds a sledge

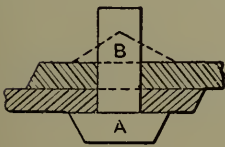

FIG. 56.

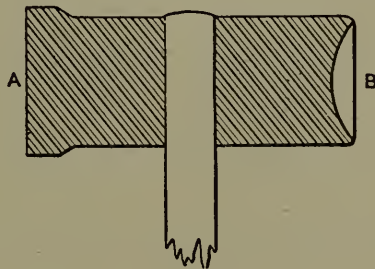

FIG. 57.

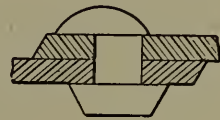

FIG. 58.

or “dolly bar” against the head of the rivet. In “button-set” or “snap” riveting, the rivet is struck a few heavy blows with a sledge to “upset” it. Then a die or “button set,” Fig. 57, is held with the spherical depression, *B*, upon the rivet; the head, *A*, is struck with the sledge, and the rivet head is thus formed.

In machine-riveting a die similar to *B* is held firmly in the machine and a similar die opposite to it is attached to the piston of a steam, hydraulic, or pneumatic cylinder. A rivet, properly placed in holes in the members to be connected, is put between the dies and pressure is applied to the piston. The movable die is forced forward and a head formed on the rivet.

The relative merits of machine- and hand-riveting have been much discussed. Either method carefully carried out will produce a good serviceable joint. If in hand-riveting the first few blows be light the rivet will not be properly upset, the shank will be loose in the hole, and a leaky rivet results. If in machine-riveting the axis of the rivet does not coincide with the axis of the dies, an off-set head results. (See Fig. 58.) In large shops where work must be turned out economically in large quantities, machines must be used. But there are always places inaccessible to machines, where the rivets must be driven by hand.

63. Perforation of Plates.—Holes for the reception of rivets are usually punched, although for thick plates and very careful work they are sometimes drilled. If a row of holes be *punched* in a plate, and a similar row as to size and spacing be *drilled* in the same plate, testing to rupture will show that the punched plate is weaker than the drilled one. If the punched plate had been annealed it would have been nearly restored to the strength of the drilled one. If the holes had been punched $\frac{1}{16}$ inch to $\frac{1}{8}$ inch small in diameter and reamed to size, the plate would have been as strong as the drilled one. These facts, which have been experimentally determined, point to the following conclusions: First, punching injures the material and produces weakness. Second, the injury is due to stresses caused by the severe action of the punch, since annealing, which furnishes opportunity for equalizing of stress, restores the strength. Third, the injury is only in the immediate vicinity of the punched hole, since reaming out $\frac{1}{16}$ inch or less on a side removes all the injured material.

In ordinary boiler work the plates are simply punched and riveted. If better work is required the plates must be drilled, or punched small and reamed, or punched and annealed. Drilling is slow and therefore expensive; annealing is apt to change the plates and requires large expensive furnaces. Punching small and reaming is probably the best method. In this connection, Prof. A. B. W. Kennedy (see Proc. Inst. M. E., 1888, pp. 546-547) has called attention to the phenomenon of greater unit tensile strength of the plate along the perforations than of the original unperforated plate.* Stoney ("Strength and Proportion of Riveted Joints," London, 1885) has compiled the following table:

TABLE I.—RELATIVE PERCENTAGE OF STRENGTH OF STEEL PLATES PERFORATED IN DIFFERENT WAYS.

Specimens.	Unit Strength of Net Section between Holes compared with that of the Solid Plate (100 Per Cent).			
	$\frac{1}{4}$ Inch.	$\frac{1}{2}$ Inch.	$\frac{3}{4}$ Inch.	1 Inch.
	Per Cent.	Per Cent.	Per Cent.	Per Cent.
Punched.	101.0	94.2	82.5	75.8
Punched and annealed.	105.6	105.6	101.0	100.3
Drilled.	113.8	111.1	106.4	106.1

For punched and reamed holes the same percentages may be used as for drilled.

Professor Kennedy gives constants which may be obtained from the following formula:

Excess of unit strength of drilled steel plates in net section over unperforated section

$$= \left(2 + \frac{6.124}{\sqrt{t}} \right) \left(\frac{4.5 - r}{2.5} \right) \text{ per cent.}$$

t is the thickness of plate in inches and r the ratio of pitch

* This reported phenomenon is corroborated by tests made at Watertown Arsenal. See Tests of Metals, 1886, pp. 1264, 1557.

divided by diameter of hole. No data exist relative to iron plates in this matter.

64. Kinds of Joints.—Riveted joints are of two general kinds: First, LAP-JOINTS, in which the sheets to be joined are lapped on each other and joined by a seam of rivets, as in Fig. 59*a*. Second, BUTT-JOINTS, in which the edges of the sheets abut against each

FIG. 59.

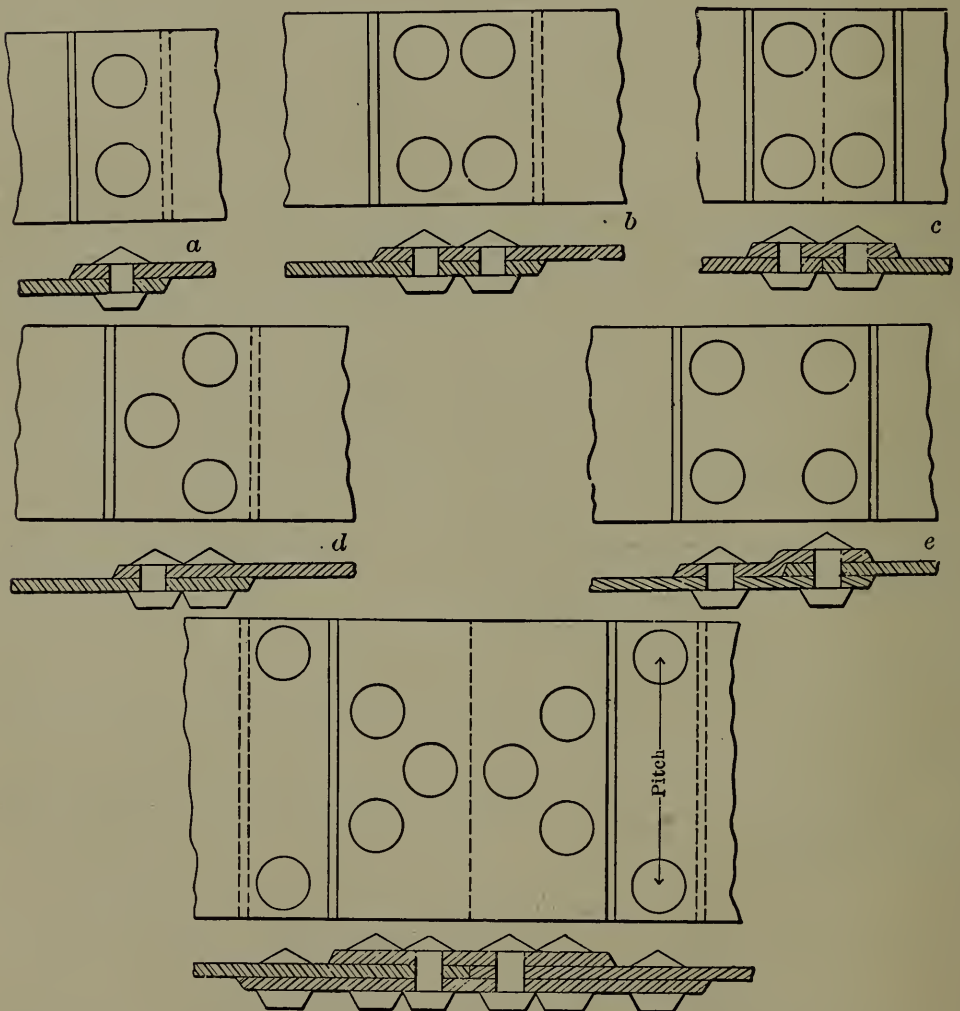

FIG. 60.

other, and a strip called a "cover-plate" or "butt-strap" is riveted to the edge of each sheet, as in *c*. In recent years a lap-joint

with a single cover-plate has been used somewhat. It is shown in Fig. 59*e*.

There are two chief kinds of riveting: Single, in which there is but one row of rivets, as in Fig. 59*a*; and double, where there are two rows.

Double riveting is subdivided into "chain-riveting," Fig. 59*b*, and "zigzag" or "staggered" riveting, Fig. 59*d*.

Lap-joints may be single, double chain, or double staggered riveted.

Butt-joints may have a single strap as in *c*, or double strap; *i.e.*, an exactly similar one is placed on the other side of the joint. Butt-joints with either single or double strap may be single, double chain, or double staggered riveted. In butt-joints single cover-plates should be nine-eighths of the thickness of plates and double cover-plates five-eighths.

To sum up, there are:

Lap-joints.	{	Single-riveted Double chain-riveted Double staggered-riveted						
Butt-joints.	{	<table style="border-collapse: collapse; margin-left: 10px;"> <tr> <td style="padding-right: 10px;">Single-strap.</td> <td style="font-size: 2em; vertical-align: middle;">{</td> <td style="padding-left: 10px;">Single-riveted Double chain-riveted Double staggered-riveted</td> </tr> <tr> <td style="padding-right: 10px;">Double-strap.</td> <td style="font-size: 2em; vertical-align: middle;">{</td> <td style="padding-left: 10px;">Single-riveted Double chain-riveted Double staggered-riveted</td> </tr> </table>	Single-strap.	{	Single-riveted Double chain-riveted Double staggered-riveted	Double-strap.	{	Single-riveted Double chain-riveted Double staggered-riveted
Single-strap.	{	Single-riveted Double chain-riveted Double staggered-riveted						
Double-strap.	{	Single-riveted Double chain-riveted Double staggered-riveted						

The demands of modern practice have added triple and quadruple joints to the foregoing. In high-pressure cylindrical boilers, for instance, common practice is to employ for the longitudinal seam the highly efficient joint shown in Fig. 60. Here we have a triple-riveted butt-joint with double cover-plates; on each side of the joint two rows of rivets are in double shear and one row, the outer, is in single shear.

65. Failure of Joint.—A riveted joint may yield in any one of four ways: First, by the rivet shearing (Fig. 61*a*); second, by the plate yielding to tension on the line *AB* (Fig. 61*b*); third, by the

rivet tearing out through the margin, as in *c*; fourth, the rivet and sheet bear upon each other at *D* and *E* in *d*, and are both in compression. If the unit stress upon these surfaces becomes too great, the rivet is weakened to resist shearing, or the plate to resist tension, and failure may occur. This pressure of the

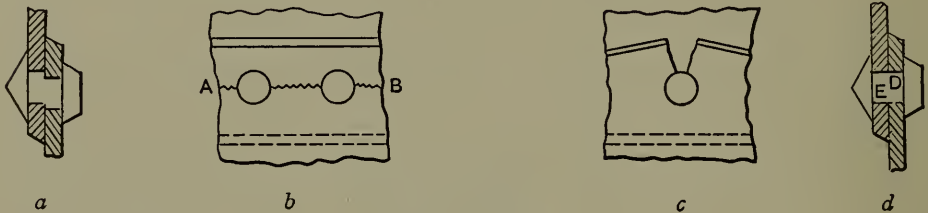

FIG. 61.

rivet on the sheet is called "bearing pressure." It is obvious that the strongest or most efficient joint in any case will be one which is so proportioned that the tendency to fail will be equal in all of the ways.

66. Strength of Materials Used.—As a preliminary to the designing of joints it is necessary to know the strength of the rivets to resist shear, of the plate to resist tension, and of the rivets and plates to resist bearing pressure. These values must not be taken from tables of the strength of the materials of which the plate and rivets are made, but must be derived from experiments upon actual riveted joints tested to rupture. The reason for this is that the conditions of stress are modified somewhat in the joint. For instance, in single-strap butt-joints, and in lap-joints, the line of stress being the center line of plates, and the plates joined being offset, flexure results and the plate is weaker to resist tension, the rivets in the mean time being subjected to tension as well as shear; if the joint yield to this stress in the slightest degree the "bearing pressure" is localized and becomes more destructive. The effect of friction between the surfaces of the plates under the pressure at which they are "gripped" by the rivets is another item of considerable importance. Ex-

tensive and accurate experiments have been made upon actual joints and the results have been published.*

The following table has been compiled as representing fair average results, and the values here given may be used for ordinary joints:

TABLE II.—VALUES OF f_t , f_s , AND f_c FOR DIFFERENT KINDS OF JOINTS.

Kind of Joint.	Iron.			Steel.		
	f_t	f_s	f_c	f_t	f_s	f_c
Lap-joint, single-riveted, punched holes.	40000	38000	67000	47500	85000
Lap-joint, single-riveted, drilled holes.	45000	36000	67000	45000	85000
Lap-joint, double-riveted, punched holes.	45000	40000	67000	48000	85000
Lap-joint, double-riveted, drilled holes.	50000	38000	67000	46000	85000
Butt-joints, single cover: Use values given for lap-joints.						
Butt-joints, double cover, single-riveted, punched holes.	40000	42500	89000	48000	100000
Butt-joints, double cover, single-riveted, drilled holes.	45000	41000	89000	46000	100000
Butt-joints, double cover, double-riveted, punched holes.	45000	38000	89000	47500	100000
Butt-joints, double cover, double-riveted, drilled holes.	50000	36000	89000	45000	100000
† Original plate.	50000	60000		
† Original bar.	45000	52000	

It will be noted that the values of f_t are not given for steel. The tensile strength of steel varies through a considerable range due largely to differences in chemical constitution; it also follows a rough law of inverse proportion to the thickness of plates; *i.e.*, thin plates will be almost sure to show higher tensile strength than thicker plates of the same composition. Furthermore,

* See Proc. Inst. of Mech. Eng., 1881, 1882, 1885, 1888; Tests of Metals, Watertown Arsenal, 1885, 1886, 1887, 1891, 1895, 1896. Stoney's "Strength and Proportions of Riveted Joints," London, 1885.

† If the original material varies from this, the values given above should be varied proportionately.

the method of perforation greatly affects the strength of the plates, as has been pointed out in § 63. Ordinary boiler-plates have a unit tensile strength ranging from 55,000 lbs. to 62,000 lbs. per square inch. For ordinary calculations f_t may be taken as 55,000 lbs. for punched plates and 60,000 for drilled plates. The shearing strength of rivets also varies inversely as their size, but these differences are slight.

67. Strength, Proportions, and Efficiency of Joints.—No riveted joint can be as strong as the unperforated plate. The ratio of strength of joint to strength of unperforated plate is called the **JOINT EFFICIENCY**.

As stated in § 65 the highest efficiency for a joint is obtained when the relations between thickness of plate, diameter of rivet, pitch, and margin are such that the tendency for the joint to fail in any one way does not exceed the tendency for it to fail in any other way. Formulæ can be developed for finding their proper values for each form of joint.

Let d = diameter of rivet-hole in inches;

a = pitch of rivets in inches;

t = thickness of plates in inches;

f_t = tensile strength of plates in pounds per square inch;

f_c = crushing strength of rivets or plates, if rivets are in single shear, pounds per square inch;

f'_c = crushing strength of rivets or plates, if rivets are in double shear, pounds per square inch;

f_s = shearing strength of rivets in single shear, pounds per square inch;

f'_s = shearing strength of rivets in double shear, pounds per square inch.

Each joint may be treated as if made up of a successive series of similar strips, each unit strip having a width equal to a , the distance between centers of two consecutive rivets in the same

row (see Fig. 62). If the stresses and proportions for one such strip are determined, the results obtained will, of course, apply to all of the others, and consequently to the whole joint. Consider such a strip of thickness t and width a .

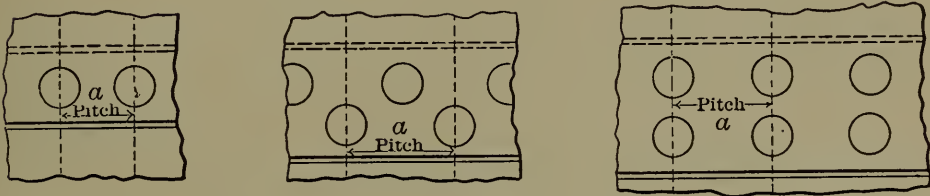

FIG. 62.

- Let P = ultimate tensile strength of unperforated strip, pounds;
- T = ultimate tensile strength of net section of strip, pounds;
- S = ultimate shearing resistance of all rivets in strip, pounds;
- C = ultimate crushing resistance of all rivets or sides of holes, pounds;
- E = efficiency of joint.

To illustrate this method, consider first the simplest joint, *i.e.*, the single-riveted lap-joint.

The unperforated strip has a tensile strength

$$P = atf_t \dots \dots \dots (1)$$

Along the row of rivets the net width of plate is less than the total width of the strip by an amount equal to the diameter of the rivet, and consequently the net tensile strength of the strip is expressed by the equation

$$T = (a - d)t f_t \dots \dots \dots (2)$$

In each unit strip there is but a single rivet with but one surface in shear, hence

$$S = \frac{\pi}{4} d^2 f_s = .7854 d^2 f_s \dots \dots \dots (3)$$

The crushing resistance of the rivet, or of the plate around the hole, may be written as

$$C = dtf_c. \quad (4)$$

For highest efficiency $T = S = C$.

Equating S and C , (3) and (4), $.7854d^2f_s = dtf_c$.

$$\therefore d = 1.27t \frac{f_c}{f_s}. \quad (5)$$

This equation gives the proper theoretical value of d for a given value of t , and for materials represented by f_c and f_s .

Equating T and S , (2) and (3),

$$(a-d)t f_t = .7854d^2 f_s.$$

$$\therefore a = \frac{.7854d^2 f_s}{t f_t} + d. \quad (6)$$

This gives the proper theoretical pitch. The *efficiency* of the joint is obtained by dividing T , S , or C by P .

In most cases the values of d and a as determined by (5) and (6) cannot be strictly adhered to. Stock sizes of rivets must be used in practice, and there are also limitations connected with the largest sizes it is convenient to drive. These equations, furthermore, do not take into consideration the stresses set up in the rivets when their shrinkage, due to cooling, is resisted by the plates, an item which may become excessive with the smaller diameters. The spacing of the rivets must also be modified quite frequently by the proportions of the parts to be connected, by allowance for proper space to form the heads, and by provision for tightness. In practice it is therefore often necessary to depart from these values.

It must be borne in mind, however, that any departure from the values of d and a given in (5) and (6) destroys the equality

between T , S , and C , and if such departure is made, the actual value of T , S , and C should be determined (by substitution of the values of d and a decided upon). The *efficiency* of the joint will then be found by dividing whichever has the smallest value, T , S , or C , by P .

If the REAL efficiency of the joint is desired, the value of T must be obtained by increasing f_t by the amount called for by the perforation of the plates. As explained in § 63 this will be $\left(2 + \frac{6.14}{\sqrt{t}}\right) \left(\frac{4.5-r}{2.5}\right)$ per cent greater than the f_t of the original, unperforated plate.

68. Problem.—The following problem illustrates the method of using Table II in connection with the formulæ (5) and (6).

What should be the dimensions of rivet-hole and pitch for a single-riveted lap-joint for $\frac{3}{8}$ -inch iron plates using iron rivets?

Table II gives as values of f_t , f_s , and f_c 40,000, 38,000, and 67,000 lbs. per square inch, respectively, for this form of joint.

$$t = \frac{3}{8}'' = .375''.$$

Substituting these values, equation (5) becomes

$$d = 1.27 \times .375 \times \frac{67000}{38000} = .84''$$

and equation (6)

$$a = \frac{.7854 \times .84^2 \times 38000}{.375 \times 40000} + .84 = 2.24 \text{ inches.}$$

69. Proportions of Single-riveted Lap-joints.—Table III and Table IV have been computed in this way. As Table IV refers to steel joints, the values of f_t , f_s , and f_c are 55,000, 47,500, and 85,000 lbs. per square inch, respectively.

TABLE III.—PROPORTIONS OF SINGLE-RIVETED LAP-JOINTS, IRON PLATES, AND RIVETS, PUNCHED HOLES.

t	$d=1.27t\frac{f_c}{f_s}$	$a=\frac{.7854d^2f_s}{tf_t}+d$	d	a
$\frac{3}{16}$.42	1.12		
$\frac{1}{4}$.56	1.49		
$\frac{5}{16}$.70	1.86		
$\frac{3}{8}$.84	2.24	$\frac{5}{8}$	$1\frac{5}{8}$
$\frac{1}{2}$	1.12	2.98	$\frac{5}{8}-\frac{3}{4}$	$1\frac{3}{4}-2$
$\frac{5}{8}$	1.40	3.98	$\frac{3}{4}-\frac{15}{16}$	$2-2\frac{5}{16}$
$\frac{3}{4}$	1.68	4.47	$\frac{3}{4}-1$	$2-2\frac{3}{8}$
$\frac{7}{8}$	1.96	5.22	$1-1\frac{1}{8}$	$2\frac{1}{4}-2\frac{5}{8}$
1	2.24	5.96	$1-1\frac{3}{8}$	$2\frac{1}{2}-3$
$1\frac{1}{8}$	2.52	6.71	$1-1\frac{1}{4}$	$2\frac{1}{4}-2\frac{3}{4}$
			$1\frac{1}{8}-1\frac{3}{8}$	$2\frac{3}{8}-3$

Column 1 gives the thickness of plate; columns 2 and 3 give the corresponding calculated values of d and a for joint of maximum efficiency; columns 4 and 5 give the values of d and a as compiled by Twiddell in the Proc. Inst. of M. E., 1881, pp. 293-295, from boiler-makers' practice. It will be noted that the rivets used in practice (see column 4) are considerably smaller in diameter than those called for in column 2, and that this difference grows more and more marked as the thickness of the plate increases. The reason for this is that the difficulty in driving rivets increases very rapidly with their size, $1\frac{1}{4}$ or $1\frac{3}{8}$ inches being the largest rivet that can be driven conveniently. The equality of strength to resist bearing pressure and shear is therefore sacrificed to convenience in manipulation. As the diameter of the rivet is increased the area to resist bearing pressure increases less rapidly than the area to resist shear (the thickness of the plate remaining the same), the former varying as d and the latter as d^2 ; therefore if d is not increased as much as is necessary for equality of strength, the excess of strength will be to resist bearing pressure. If the other parts of the joint are made as strong as the rivet in shear, and this strength is calculated from the stress to be resisted, the joint will evidently be correctly proportioned. As machine-riveting comes into more general

use and pneumatic tools are used in "hand-work," this discrepancy will tend to disappear.

TABLE IV.—PROPORTIONS OF SINGLE-RIVETED LAP-JOINTS, STEEL PLATES, AND RIVETS, PUNCHED HOLES.

	$d=1.27t\frac{f_c}{f_s}$	$a=\frac{.7854d^2f_s}{tf_t}+d$	d	a
$\frac{3}{16}$.43	1.08	.47	$1\frac{1}{8}$
$\frac{1}{4}$.57	1.45	.61	$1\frac{7}{16}$
$\frac{5}{16}$.71	1.81	.81	2
$\frac{3}{8}$.86	2.17	.94	$2\frac{5}{16}$
$\frac{1}{2}$	1.14	2.89	1.19	3
$\frac{5}{8}$	1.43	3.61		
$\frac{3}{4}$	1.71	4.34		
$\frac{7}{8}$	2.00	5.06		
1	2.28	5.78		
$1\frac{1}{8}$	2.57	6.50		

Column 1 gives the thickness of the plate; columns 2 and 3 give the values of d and a calculated for joint of maximum efficiency; columns 4 and 5 give proportions from practice, the authority being Moberly (see Stoney, "Strength and Proportions of Riveted Joints," p. 80). It will be noted how closely the theory and practice agree here for boiler joints.

70. **Single-riveted Butt-joints.**—To develop the general formulæ for the values of a and d for single-riveted butt-joints with double cover-plates the same general method used in § 67 applies.

In this case the rivets are in double shear. Therefore

$$S = 2\frac{\pi d^2}{4} f_s', \dots \dots \dots (7)$$

while $T = (a-d)tf_t$, (2), as before and

$$C = dtf_c'. \dots \dots \dots (8)$$

Equating S and C , (7) and (8),

$$\frac{2\pi d^2}{4} f_s' = dt f_c'; \quad \therefore \quad \frac{\pi d}{2} f_s' = t f_c'$$

and

$$d = .64 \frac{f_c'}{f_s'} t. \quad \dots \dots \dots (9)$$

Equating T and S , (2) and (7),

$$(a-d)t f_t = 1.57 d^2 f_s';$$

$$\therefore a = \frac{1.57 d^2 f_s'}{t f_t} + d. \quad \dots \dots \dots (10)$$

For Double-riveted Lap-joints the unit strip contains two rivets, each in single shear. The following equations cover the case :

$$T = (a-d)t f_t,$$

$$S = 2 \frac{\pi d^2}{4} f_s = 1.57 d^2 f_s,$$

$$C = 2dt f_c,$$

$$d = 1.27 \frac{f_c}{f_s} t. \quad \dots \dots \dots (11)$$

$$a = \frac{1.57 d^2 f_s}{t f_t} + d. \quad \dots \dots \dots (12)$$

71. Double-riveted Butt-joint. — For double riveted butt-joints, double cover-plate, either chain or staggered riveting, there are two rivets in double shear for each unit strip.

$$T = (a-d)t f_t,$$

$$S = 4 \frac{\pi d^2}{4} f_s' = 3.14 d^2 f_s',$$

$$C = 2dtj'_c,$$

$$d = .64 \frac{j'_c}{j'_s} t. \quad \dots \quad (13)$$

$$a = \frac{3.14d^2j'_s}{tj_t} + d. \quad \dots \quad (14)$$

72. General Formulæ.—The following general equations for riveted joints have been developed by Mr. W. N. Barnard:*

The unit strip is of width equal to the pitch, the maximum pitch being taken unless all rows have the same pitch.

The general expression for the net tensile strength of the unit strip is

$$T = (a - d)tj_t. \quad \dots \quad (15)$$

The general expression for resistance to shearing of the rivets in the unit strip is

$$S = \frac{n\pi d^2}{4} j_s + \frac{2m\pi d^2}{4} j'_s, \quad \dots \quad (16)$$

in which n equals the number of rivets in single shear and m equals the number of rivets in double shear.

The general expression for resistance to crushing of the unit strip is

$$C = ndtj_c + mdtj'_c. \quad \dots \quad (17)$$

The tensile resistance of the solid strip is

$$P = atj_t. \quad \dots \quad (18)$$

Equating S and C , (16) and (17), and transposing, we get

$$d = 1.27 \frac{nj_c + mj'_c}{nj_s + 2mj'_s} t. \quad \dots \quad (19)$$

* See article, "General Formulas for Efficiency and Proportions for Riveted Joints," by Professor J. H. Barr in Sibley Journal of Engineering, Oct., 1900.

Equating T and C , (15) and (17),

$$a = \left(\frac{n f_c + m f_c'}{f_t} \right) d + d. \quad \dots \dots \dots (20)$$

Or, equating T and S , (15) and (16),

$$a = .7854 d^2 \left(\frac{n f_s + 2m f_s'}{t f_t} \right) + d. \quad \dots \dots \dots (21)$$

The following equation for efficiency has been developed on the assumption that $T = S = C$.

From $E = \frac{S}{P}$ we get, by substitution and transposition,

$$E = \frac{1}{1 + \frac{f_t}{n f_c + m f_c'}}. \quad \dots \dots \dots (22)$$

This equation is useful in finding the limiting efficiency of joint for any form and materials; the actual proportions adopted may give a lower efficiency, but can never give a higher efficiency.*

73. Other Dimensions.—The MARGIN in a riveted joint is the distance from the edge of the sheet to the rivet-hole. This must be made of such value that there shall be safety against failure by the rivet tearing out. There can be no satisfactory theoretical determination of this value; but practice and experiments with actual joints show that a joint will not yield in this way if the margin be made $= d =$ diameter of the rivet. The distance between the center lines of the rows in double chain-riveting may be taken $= 2.5d$, and in double staggered-riveting may be taken $= 1.88d$. Thus the total width of lap for single riveting equals $3d$, in double chain-riveting $= 5.5d$, and in double staggered-riveting $4.88d$.

* In the Proceedings of the Inst. of M. E., 1881, there is an article entitled "On Riveting, with Special Reference to Ship-work," M. Le Baron Clauze, which enters deeply into the development of general formulæ.

74. **Relative Efficiencies of Various Kinds of Joints.**—The actual efficiencies of joints when tested show some departure from the calculated ideal efficiencies. The following Table (V) has been compiled from the results of tests to show roughly the relative efficiencies of various types of joints:

TABLE V.—RELATIVE EFFICIENCY OF IRON JOINTS.

	Efficiency Per Cent.
Original solid plate.	100
Lap-joint, single-riveted, punched.	45
“ “ drilled.	50
“ double “	60
Butt-joint, single cover, single-riveted.	45-50
“ “ double-riveted.	60
“ double “ single-riveted.	55
“ “ “ double-riveted.	66

RELATIVE EFFICIENCY OF STEEL JOINTS.

	Efficiency Per Cent.		
	Thickness of Plates.		
	$\frac{1}{4}$ — $\frac{1}{2}$	$\frac{1}{2}$ — $\frac{3}{4}$	$\frac{3}{4}$ — 1
Original solid plate.	100	100	100
Lap-joint, single-riveted, punched.	50	45	40
“ “ drilled.	55	50	45
“ double-riveted, punched	75	70	65
“ “ drilled.	80	75	70
Butt-joint, double cover, single-riveted, drilled.	70	65	60
“ “ “ double-riveted, punched.	75	70	65
“ “ “ “ drilled.	80	75	70

These tables are from Stoney's "Strength and Proportions of Riveted Joints."

Triple and quadruple riveted butt-joints with double cover-plates show efficiencies ranging from 80 to 90 per cent.*

75. **Slippage.**—At about 25 to 35 per cent of its ultimate load SLIPPAGE takes place in a riveted joint. This is probably due to the fact that at this load the friction between the plates, owing to the pressure exerted on them by the rivets, is overcome. It

* For details of joints tested, see Tests of Metals, Watertown Arsenal, 1896.

W. O. F. C.

4

has been found the larger the cross-sectional area of the rivet the greater the percentage of ultimate load which can be withstood without slippage. It has also been found that large rivet-heads are better than small ones for the same reason.

76. Necessary Length of Rivet.—In general the rivet should have a shank $\frac{1}{16}$ inch smaller in diameter than the hole to be filled, while the head should have a diameter of from 1.6 to 2 times the diameter of hole, and a height of from .6 to .75 time the hole diameter. Especial care should be taken in the case of machine-riveting to have just enough metal projecting beyond the hole to allow for the necessary upset for the shank to fill the hole, with just enough left over to fill the die for the head.

77. Problem.—How far must the tail of the rivet project in order to satisfy the above conditions for the following case: Two plates $\frac{3}{8}$ inch thick each are to be connected, using $\frac{7}{8}$ -inch rivets in $\frac{15}{16}$ -inch holes. The head is to be cone-shaped, having an outside diameter of $1\frac{7}{8}$ inches and a height of $\frac{3}{4}$ inch.

The cubical contents of the cone head = area of base $\times \frac{1}{3}$ altitude = 2.76 square inches $\times .25$ inch = $.69$ cubic inch.

The difference in cubical contents between a hole $\frac{15}{16}$ inch in diameter by $\frac{3}{4}$ inch long and a shank $\frac{7}{8}$ inch in diameter and $\frac{3}{4}$ inch long = $\frac{3}{4} \times .7854 (\frac{15}{16}^2 - \frac{7}{8}^2) = .067$ cubic inch.

The amount required for head and upset therefore equals $.69 + .067 = .757$ cubic inch.

The area of the $\frac{7}{8}$ -inch shank = $.60$ square inch. $.757$ cubic inch, therefore, calls for a length of $\frac{.757}{.60} = 1.25$ inches. This amount would then be the projection through the plate. The length of rivet-shank called for would equal $\frac{3}{4}$ inch + $1\frac{1}{4}$ inches = 2 inches.

NOTE.—Had the head been cup-shaped, its cubical contents should have been taken as that of a spherical segment. For cup-shaped heads the diameter is about $1.7 \times$ diameter of hole, and the height about $.6 \times$ diameter of hole. The volume of the

spherical segment is given by the following rule: Multiply half the height of the segment by the area of the base and the cube of the height by .5236 and add the two products.

78. Countersunk Rivets.—Fig. 63 shows the proportions for a countersunk rivet. Countersunk rivets make a much weaker and less reliable joint than the ordinary form, and should only be used where it is absolutely necessary that the surface of the plate be free from projections.

79. Nickel-steel Rivets.—Where peculiar conditions call for great strength of rivet combined with small area, it may be found desirable to use nickel-steel rivets. Experiments made by Mr. Maunsel White (see Journal Am. Soc. of Nav. Eng., 1898) on riveted joints using nickel-steel rivets showed an average shearing resistance of 85,720 lbs. per square inch for single shear, and an average of 90,075 lbs. per square inch for double shear. These values, it will be noted, are nearly double those of the very mild steel ordinarily used. The rivets were $\frac{3}{4}$ inch in diameter, and some of the joints failed by tearing the plates, while others failed by shearing the rivets.

80. Construction of Tight Joints.—In punching holes in plates, it is, of course, necessary to have the hole in the die-block larger than the punch. The consequence is that the holes are considerably tapered and care should be exercised in joining the plates that the small ends of the holes be together as shown in Fig.

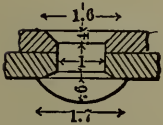

FIG. 63.



FIG. 64.

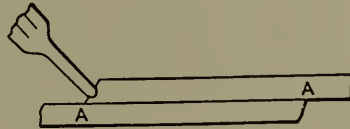

FIG. 65.

64A, and not apart as shown in Fig. 64B. It is obvious that at A the pressure on the rivet tends to draw the plates closer together, and that as the rivet cools its longitudinal shrinkage

will tend to keep it a tight fit for the hole in spite of its diametral shrinkage.

It is equally obvious that at *B* the pressure on the rivet will tend to force the plates apart and squeeze metal between them, and also that all shrinkage of the rivet will be away from the walls of the hole.

In using drilled plates care must be exercised to remove the sharp burrs left by the drill, as experience has shown that this has a considerable effect on the strength of the joint. .

Where the plates form the walls of vessels to hold fluids, the joints must be designed with a view toward tightness as well as strength. For this purpose the edges are planed at a slight bevel, and calked as shown in Fig. 65 by a tool which resembles a cold-chisel with a round nose. Pneumatic tools are used for this purpose almost entirely, as they execute more uniform and rapid work than can be done by hand. In calking great care should be exercised not to groove the plates at *A-A*, as these are danger-points for bending, and an incipient groove is very apt to develop into a crack. It is largely on this account that the round-nose calking-tool has superseded the square-nose in the best practice.

81. Materials to be Used.—The material to be used in riveted joints depends, of course, on the nature of the work, but in general it may be said that extremely mild and highly ductile steel as free from phosphorus and sulphur as possible should be used. Open-hearth steel is greatly to be preferred to Bessemer.*

82. Plates with Upset Edges.—Some boiler-makers have adopted, as an expedient for saving material, a method of using plates with thickened (upset) edges. If we let *t* represent the

* Standard specifications can be found in Kent's "Mechanical Eng. Pocket Book." The U. S. Navy Dept. has adopted standard rules for riveting naval vessels. These can be found in Marine Engineering, Jan., 1898.

thickness of the body of the plate and t' the thickness of the edge, while a represents the pitch and d the diameter of hole, then, when

$$t' = t \frac{a}{a-d},$$

the joint will be as strong as any other section of the plate, the joint being proportioned, of course, for the thickness t' . It is customary to thicken only the edges which form the longitudinal seam. This method is open to two serious objections. Unless the plates are very carefully annealed after being upset they are almost certain to be weakened by indeterminate working and cooling stresses. Moreover, although the original new joint may show as high an efficiency as if the plates throughout were of the thickness t' , as corrosion proceeds, it acts more on the plate away from the joint than at the joint, because at the latter place the plate is protected by the cover-plate or rivet-head or both. The result is a shorter life under full pressure for the boiler with thin plates and thickened edges.

83. Joints for More than Two Plates.—The joints considered thus far have dealt with the problem of connecting the edges of two plates only. In tanks and boilers which must have tight seams we are frequently confronted with the problem of joining three and even four plates. An instance is where the cross-seam and longitudinal seam of a boiler meet. The joint is made by thinning down one or more of the plates. Figs. 66 to 70 (taken from Unwin's "Machine Design") show the methods employed. Fig. 66 shows a junction of three plates, a , b , and c , where both seams are single-riveted lap-joints. It will be seen that the corner of a is simply drawn down to an edge and "tucked under" c .

Fig. 67 shows a junction of three plates where one seam is a single-riveted and the other a double-riveted lap-joint. As before, the corner of a is drawn down and tucked under c .

Fig. 68 shows the junction of three plates where both seams are single-riveted, single cover-plate butt-joints. The plates merely abut against each other, but the longitudinal cover is

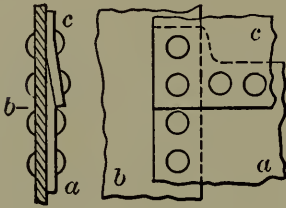

FIG. 66.

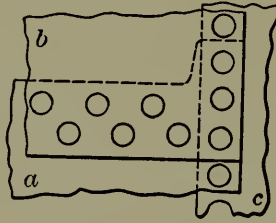

FIG. 67.

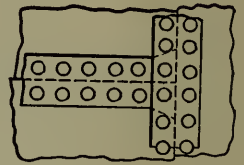

FIG. 68.

drawn down and tucked under the cross-seam cover which is thinned down to match.

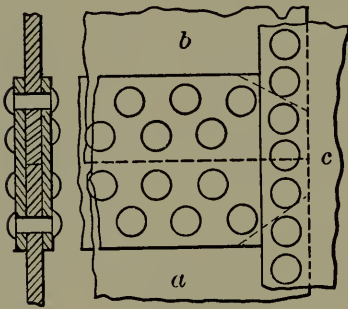

FIG. 69.

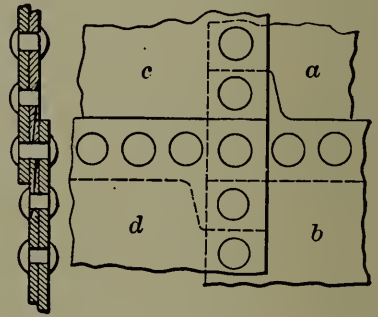

FIG. 70.

Fig. 69 also shows the junction of three plates; here the cross-seam is a single-riveted lap-joint while the longitudinal joint is a double-riveted butt-joint with double cover-plates. The upper cover-plate is planed on the end so that it can be tightly calked where it abuts against the plate *c*.

A method of joining four plates is shown in Fig. 70. Both seams are single-riveted lap-joints. *b* and *c* are both drawn down as shown.

84. Junction of Plates Not in Same Plane.—Where the plates to be joined are in different planes, it is customary to use some one of the rolled structural forms. Fig. 71 shows the method of using an angle iron for plates at a right angle to each other.

Where it is possible to turn a flange on one of the plates this method is often adopted. Care should be taken not to use too

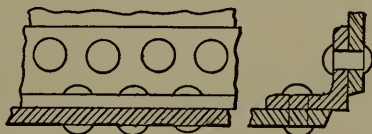

FIG. 71.



FIG. 72.

sharp a radius of curvature (the inside radius must be greater than the thickness of the plate even with the mildest steel) and the flanged plate should be thoroughly annealed after it is bent.

Fig. 72 shows the method of making flanged joints such as are frequently used in connecting boiler heads and shells.

85. Problem.—The following problem will serve to illustrate the design of riveted joints for boilers. It is required to design a horizontal tubular boiler 48 inches in diameter to carry a working pressure of 100 pounds per square inch.

A boiler of this type consists of a cylindrical shell of wrought iron or steel plates made up in length of two or more courses or sections. Each course is made by rolling a flat sheet into a hollow cylinder and joining its edges by means of a riveted joint, called the longitudinal joint or seam. The courses are joined to each other also by riveted joints, called circular joints or cross-seams. Circular heads of the same material have a flange turned all around their circumference, by means of which they are riveted to the shell. The proper thickness of plate may be determined from (I) The diameter of shell = 48 inches; (II) The working steam-pressure per square inch = 100 pounds; (III) The tensile strength of the material used; let steel plates be used of 60,000 pounds specified tensile strength.

Preliminary investigations of the conditions of stress in the cross-section of material cut by a plane (I) Through the axis; (II) At right angles to the axis, of a thin hollow cylinder, the stress being due to the excess of internal pressure per square inch.

Let L = the length of the cylindrical shell in inches;

D = the diameter of the cylindrical shell in inches;

p = the excess of internal over external pressure in pounds per square inch;

f_1 = unit tensile stress in a longitudinal section of material of the shell due to p ;

f_2 = unit tensile stress in a circular section of material of the shell due to p ;

t = thickness of plate;

f_t = ultimate tensile strength of plate.

All stresses are in pounds per square inch.

In a longitudinal section the total stress is equal to LDp , and the area of metal sustaining it = $2Lt$. Then $f_1 = \frac{Dp}{2t}$.

In a circular section the total stress = $\frac{\pi D^2 p}{4}$, and the area sustaining it = πDt , nearly. Then

$$f_2 = \frac{\pi D^2 p}{4} \times \frac{1}{\pi Dt} = \frac{Dp}{4t}.$$

Therefore the stress in the first case is twice as great as in the second; and a thin hollow cylinder is twice as strong to resist rupture on a circular section as on a longitudinal one. The latter only, therefore, need be considered in determining the thickness of plate. Equating the stress due to p in a longitudinal section, and the strength of the cross-section of plate that sustains it, we have $LDp = 2Lt f_t$. Therefore $t = \frac{Dp}{2f_t}$, the thickness of plate that would just yield to the unit pressure p . To get safe thickness, a factor of safety K must be used. It is usually equal in boiler-shells to 5 or 6. Its value is small because the material is highly resilient and the changes of pressure are gradual, *i.e.*, there are no shocks. This takes no account of the riveted joint, which

is the weakest longitudinal section, E times as strong as the solid plate, E being the joint efficiency = 0.75 if the joint be double-riveted. The formula then becomes $t = \frac{KDp}{2f_t E}$. Substituting values,

$$t = \frac{6 \times 48 \times 100}{2 \times 60000 \times 0.75} = 0.32 \text{ inch, say } \frac{5}{16} \text{ inch.}$$

The circular joints will be single-riveted and joint efficiency will = 0.50. But the stress is only one half as great as in the longitudinal joint, and therefore it is stronger in the proportion 0.50×2 to 0.75, or 1 to 0.75. From this it is seen that a circular joint whose efficiency is 0.50 is as strong as the solid plate in a longitudinal section. From the value of t the joints may now be designed.

Consider first the cross-seam. This is a single-riveted lap-joint. Assume drilled holes.

Equations (5),

$$d = 1.27 \frac{f_c}{f_s} t,$$

and (6),
$$a = \frac{.7854 d^2 f_s}{t f_t} + d,$$

apply, while from Table II we get as values of f_t , f_s , f_c , 60,000, 45,000, and 85,000 pounds per square inch respectively for steel plates and rivets.

$$\therefore d = 1.27 \times \frac{85000}{45000} \times .3125 = .75 \text{ inch}$$

and
$$a = \frac{.7854 \times .75^2 \times 45000}{.3125 \times 60000} + .75 = 1.81 \text{ inches, say } 1\frac{13}{16} \text{ inches.}$$

The margin = $d = .75$ inch.

The lap of the cross-seam = $3d = 2.25$ inches.

The longitudinal seam will be a double staggered lap-joint.

Equations (11) and (12) apply:

$$d = 1.27 \frac{f_c}{f_s} t, \quad \text{and} \quad a = \frac{1.57 d^2 f_s}{t f_t} + d.$$

From Table II, $f_t = 60,000$, $f_s = 46,000$, and $f_c = 85,000$;

$$\therefore d = 1.27 \times \frac{85000}{46000} \times .3125 = .74 \text{ inch, say } .75,$$

$$\text{and} \quad a = \frac{1.57 \times .75^2 \times 46000}{.3125 \times 60000} + .75 = 2.93 \text{ inches, say } 2\frac{1}{8} \text{ inches.}$$

The distance between the rows $= 1.88d = 1.41$ inches, say $1\frac{7}{8}$ inches. The total lap in the longitudinal joint $= 4.88d = 3.66$ inches, say $3\frac{1}{8}$ inches.

The joints are therefore completely determined, and a detail of each, giving dimensions, may be drawn for the use of the workmen who make the templets and lay out the sheets.

Having determined the proportion of the joints, let these dimensions be used to calculate the actual efficiency of the longitudinal seam.

Assume that the natural tensile strength of the unperforated bar is 60,000 lbs. per square inch.

The excess of strength of drilled steel plates in net section over unperforated section (see § 63) is

$$\left(2 + \frac{6.124}{\sqrt{t}}\right) \left(\frac{4.5 - r}{2.5}\right) \text{ per cent.}$$

$$\text{Here} \quad t = .3125 \text{ in.} \quad \text{and} \quad r = \frac{a}{d} = \frac{2.9375}{.75} = 3.92;$$

$$\therefore \text{excess due to perforation} = 3\%, \text{ nearly.}$$

$$60,000 \times 1.03 = 61,800 = j_t.$$

$$j_s = 46,000 \text{ from Table II.}$$

$$j_c = 85,000 \quad \text{“} \quad \text{“} \quad \text{“}$$

$$T = (a - d)tj_t = (2.9375 - .75)(.3125 \times 61,800) = 42,250 \text{ lbs.}$$

$$S = 1.57d^2j_s = 1.57 \times .75^2 \times 46,000 = 40,625 \text{ lbs.}$$

$$C = 2dtj_c = 2 \times .75 \times .3125 \times 85,000 = 39,845 \text{ lbs.}$$

$$P = aj_t = 2.9375 \times 60,000 \times .3125 = 55,075 \text{ lbs.}$$

Of T , S , and C , the latter has the smallest value; the actual efficiency of the joint may be taken as $\frac{C}{P} = \frac{39845}{55075} = .7235$ or 72.35%.

Since T , S , and C are unequal it is evident that there has been departure from the conditions for maximum efficiency. There are two ways of restoring this equality, or at least diminishing the inequality. If a be slightly decreased, T and P will be proportionately decreased and S and C will have the same values as before.

Leaving a as before and increasing d , increases S as the square of d and C as d , while T and P remain as before.

Inspection shows that T exceeds C by 5.7 per cent. Therefore a may be decreased by this percentage, or .17 inch. This is approximately $\frac{3}{16}$ inch and reduces the pitch from $2\frac{1}{8}$ to $2\frac{3}{4}$ inches.

Using this value of a gives as the excess strength due to perforation 4.33 per cent.

$$\therefore j_t = 62,600 \text{ lbs.,}$$

$$T = 39,125 \text{ lbs.,}$$

$$S = 40,625 \text{ lbs.,}$$

$$C = 39,845 \text{ lbs.,}$$

$$P = 51,560 \text{ lbs.,}$$

$$E = \frac{T}{P} = \frac{39125}{51560} = 75.88\%.$$

The second method of balancing T , S , and C would be by

increasing d . The next commercial size above $\frac{3}{4}$ inch would be $\frac{13}{16}$ inch. Leave $a = 2\frac{15}{16}$ inches, and increase d to $\frac{13}{16}$ inch, and first calculate the excess strength due to perforation.

$$t = .3125 \text{ inch, } r = \frac{a}{d} = \frac{2.9375}{.8125}.$$

Using these values, the excess = 4.57 per cent.

$$f_t = 62,750 \text{ lbs.,}$$

$$T = 41,670 \text{ lbs.,}$$

$$S = 47,675 \text{ lbs.,}$$

$$C = 43,165 \text{ lbs.,}$$

$$P = 55,075 \text{ lbs.,}$$

and, since T is least,

$$E = \frac{T}{P} = \frac{41670}{55075} = 75.66\%.$$

The best result is that obtained by keeping $d = \frac{3}{4}$ inch, but changing a to $2\frac{3}{4}$ inches, and it would be advantageous to make these the proportions of the joints rather than those first determined.

The next step is to check back, using the proportions decided upon, for the actual factor of safety which should not be less than 5.

From the equation (p. 107) $t = \frac{KDp}{2f_tE}$, we have

$$K = \frac{2f_tEt}{Dp}.$$

$$\therefore K = \frac{2 \times 62600 \times .7588 \times .3125}{48 \times 100} = 6.18.$$

Attention should be called to the fact that the ordinary and less correct method of calculating efficiencies ignores the excess

strength due to perforation, and the efficiency is simply taken as $\frac{T}{P}$.

With $a = 2\frac{1}{8}$ inches, and $d = \frac{3}{4}$ inch, this would give us

$$E = \frac{41015}{55075} = 74.47\%, \text{ instead of } 72.35\%.$$

With $a = 2\frac{3}{4}$ inches and $d = \frac{3}{4}$ inch, it would give us

$$E = \frac{37500}{51560} = 72.71\%, \text{ instead of } 75.88\%.$$

With $a = 2\frac{1}{8}$ inches and $d = \frac{1}{8}$ inch, it would give

$$E = \frac{39640}{55075} = 71.97\%, \text{ instead of } 75.66\%.$$

CHAPTER VIII.

BOLTS AND SCREWS.

86. Classification and Definition.—Bolts and screws may be classified as follows: I. Bolts; II. Studs; III. Cap-screws, or Tap-bolts; IV. Set-screws; V. Machine screws; VI. Screws for power transmission.

A “bolt” consists of a head and round body on which a thread is cut, and upon which a nut is screwed. When a bolt is used to connect machine parts, a hole the size of the body of the bolt is drilled entirely through both parts, the bolt is put through, and the nut screwed down upon the washer. (See Fig. 73.)

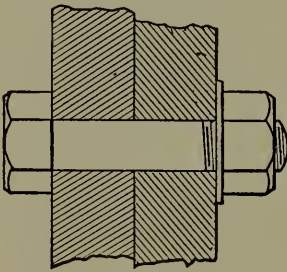

FIG. 73.

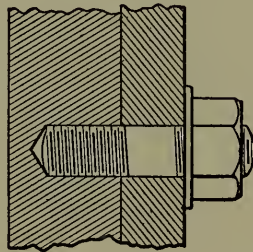

FIG. 74.

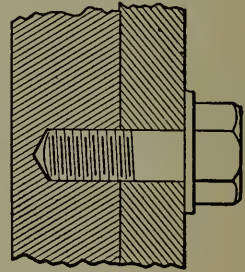

FIG. 75.

A “stud” is a piece of round metal with a thread cut upon each end. One end is screwed into a tapped hole in some part of a machine, and the piece to be held against it, having a hole the size of the body of the stud, is put on and a nut is screwed upon the other end of the stud against the piece to be held. (See Fig. 74.)

A "cap-screw" is a substitute for a stud, and consists of a head and body on which a thread is cut. (See Fig. 75.) The screw is passed through the removable part and screwed into a tapped hole in the part to which it is attached. A cap-screw is a stud with a head substituted for the nut.

A hole should never be tapped into a cast-iron machine part when it can be avoided. Cast iron is not good material for the thread of a nut, since it is weak and brittle and tends to crumble. In very many cases, however, it is absolutely necessary to tap into cast iron. It is then better to use studs if the attached part needs to be removed often, because studs are put in once for all, and the cast-iron thread would be worn out eventually if cap-screws were used.

The form of the United States standard screw-thread is shown in Fig. 76. The sides of the thread make an angle of

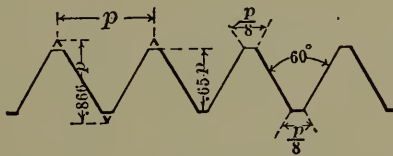

FIG. 76.

60° . Instead of coming to a sharp point, the threads have a flat at top and bottom whose width is $=\frac{1}{8}p$, p being the pitch.

Table VI gives the standard proportions.

When one machine part surrounds another, as a pulley-hub surrounds a shaft, relative motion of the two is often prevented by means of a "set-screw," which is a threaded body with a small square head (Fig. 77). The end is either pointed as in Fig. 77, *b*, or cupped as in Fig. 77, *c*, and is forced against the inner part by screwing through a tapped hole in the outer part.

Data relative to the holding power of set-screws will be found in § 109, p. 148.

TABLE VI.—U. S. STANDARD SCREW-THREADS.

Bolts and Threads.						Hex. Nuts and Heads.					Sq. N and H.
Diameter of Bolt.	Threads per Inch.	Diameter of Root of Thread.	Width of Flat.	Area of Bolt Body.	Area of Root of Thread.	Short Diameter, Rough.	Short Diameter, Finish.	Long Diameter, Rough.	Thickness, Rough.	Thickness, Finish.	Long Diameter, Rough.
Ins.		Ins.	Ins.	Sq. Ins.	Sq. Ins.	Ins.	Ins.	Ins.	Ins.	Ins.	Ins.
$\frac{1}{4}$	20	.185	.0062	.049	.027	$\frac{1}{8}$	$\frac{7}{16}$	$\frac{3}{8}$	$\frac{1}{4}$	$\frac{3}{16}$	$\frac{7}{16}$
$\frac{5}{16}$	18	.240	.0074	.077	.045	$\frac{1}{8}$	$\frac{17}{32}$	$\frac{11}{16}$	$\frac{1}{4}$	$\frac{5}{16}$	$\frac{10}{16}$
$\frac{3}{8}$	16	.294	.0078	.110	.068	$\frac{1}{8}$	$\frac{11}{16}$	$\frac{51}{64}$	$\frac{3}{8}$	$\frac{7}{16}$	$\frac{13}{16}$
$\frac{7}{16}$	14	.344	.0089	.150	.093	$\frac{1}{8}$	$\frac{33}{64}$	$\frac{17}{32}$	$\frac{3}{8}$	$\frac{7}{16}$	$\frac{17}{16}$
$\frac{1}{2}$	13	.400	.0096	.196	.126	$\frac{1}{8}$	$\frac{13}{16}$	I	$\frac{1}{2}$	$\frac{7}{16}$	$\frac{17}{16}$
$\frac{9}{16}$	12	.454	.0104	.249	.162	$\frac{3}{16}$	$\frac{29}{32}$	$\frac{1}{4}$	$\frac{9}{16}$	$\frac{1}{2}$	$\frac{23}{16}$
$\frac{5}{8}$	11	.507	.0113	.307	.202	$\frac{1}{16}$	I	$\frac{7}{32}$	$\frac{5}{8}$	$\frac{9}{16}$	$\frac{12}{16}$
$\frac{3}{4}$	10	.620	.0125	.442	.302	$\frac{1}{4}$	$\frac{1}{16}$	$\frac{7}{16}$	$\frac{3}{4}$	$\frac{13}{16}$	$\frac{13}{16}$
$\frac{7}{8}$	9	.731	.0138	.601	.420	$\frac{1}{16}$	$\frac{1}{8}$	$\frac{21}{32}$	$\frac{7}{8}$	$\frac{15}{16}$	$\frac{23}{16}$
I	8	.837	.0156	.785	.550	$\frac{1}{8}$	$\frac{1}{16}$	$\frac{1}{8}$	I	$\frac{15}{16}$	$\frac{23}{16}$
$\frac{1}{8}$	7	.940	.0178	.994	.694	$\frac{1}{16}$	$\frac{1}{4}$	$\frac{3}{32}$	$\frac{1}{8}$	$\frac{1}{16}$	$\frac{9}{16}$
$\frac{1}{4}$	7	1.065	.0178	1.227	.893	2	$\frac{15}{16}$	$\frac{25}{16}$	$\frac{1}{4}$	$\frac{3}{16}$	$\frac{53}{16}$
$\frac{3}{8}$	6	1.160	.0208	1.485	1.057	$\frac{3}{16}$	$\frac{21}{16}$	$\frac{27}{32}$	$\frac{3}{8}$	$\frac{1}{16}$	$\frac{33}{16}$
$\frac{1}{2}$	6	1.284	.0208	1.767	1.295	$\frac{23}{32}$	$\frac{25}{16}$	$\frac{27}{16}$	$\frac{1}{2}$	$\frac{7}{16}$	$\frac{33}{16}$
$\frac{5}{8}$	$5\frac{1}{2}$	1.389	.0227	2.074	1.515	$\frac{21}{16}$	$\frac{21}{2}$	$\frac{231}{32}$	$\frac{5}{8}$	$\frac{1}{16}$	$\frac{35}{8}$
$\frac{3}{4}$	5	1.491	.0250	2.405	1.746	$\frac{23}{4}$	$\frac{211}{16}$	$\frac{31}{16}$	$\frac{3}{4}$	$\frac{11}{16}$	$\frac{57}{16}$
$\frac{7}{8}$	5	1.616	.0250	2.761	2.051	$\frac{215}{16}$	$\frac{27}{8}$	$\frac{313}{32}$	$\frac{7}{8}$	$\frac{13}{16}$	$\frac{43}{16}$
2	$4\frac{1}{2}$	1.712	.0277	3.142	2.302	$\frac{31}{8}$	$\frac{31}{16}$	$\frac{35}{8}$	2	$\frac{15}{16}$	$\frac{47}{16}$
$2\frac{1}{4}$	$4\frac{1}{2}$	1.962	.0277	3.976	3.023	$\frac{33}{2}$	$\frac{315}{16}$	$\frac{41}{16}$	$2\frac{1}{4}$	$\frac{3}{8}$	$\frac{47}{16}$
$2\frac{1}{2}$	4	2.176	.0312	4.909	3.719	$\frac{37}{8}$	$\frac{315}{16}$	$\frac{41}{2}$	$2\frac{1}{2}$	$\frac{7}{16}$	$\frac{53}{16}$
$2\frac{3}{4}$	4	2.426	.0312	5.940	4.620	$\frac{41}{4}$	$\frac{415}{16}$	$\frac{439}{32}$	$2\frac{3}{4}$	$\frac{21}{16}$	6
3	$3\frac{1}{2}$	2.629	.0357	7.069	5.428	$\frac{45}{8}$	$\frac{415}{16}$	$\frac{53}{8}$	3	$\frac{215}{16}$	$\frac{617}{32}$
$3\frac{1}{4}$	$3\frac{1}{2}$	2.879	.0357	8.296	6.510	5	$\frac{15}{16}$	$\frac{513}{16}$	$3\frac{1}{4}$	$\frac{31}{16}$	$\frac{71}{16}$
$3\frac{1}{2}$	$3\frac{1}{4}$	3.100	.0384	9.621	7.548	$\frac{53}{8}$	$\frac{515}{16}$	$\frac{67}{8}$	$3\frac{1}{2}$	$\frac{315}{16}$	$\frac{73}{16}$
$3\frac{3}{4}$	3	3.317	.0413	11.045	8.641	$\frac{57}{4}$	$\frac{515}{16}$	$\frac{631}{32}$	$3\frac{3}{4}$	$\frac{311}{16}$	$\frac{81}{8}$
4	3	3.567	.0413	12.566	9.963	$\frac{61}{8}$	$\frac{615}{16}$	$\frac{73}{32}$	4	$\frac{315}{16}$	$\frac{841}{16}$
$4\frac{1}{4}$	$2\frac{7}{8}$	3.798	.0435	14.186	11.329	$\frac{63}{2}$	$\frac{615}{16}$	$\frac{79}{16}$	$4\frac{1}{4}$	$\frac{315}{16}$	$\frac{913}{16}$
$4\frac{1}{2}$	$2\frac{3}{4}$	4.028	.0454	15.904	12.753	$\frac{67}{8}$	$\frac{613}{16}$	$\frac{731}{32}$	$4\frac{1}{2}$	$\frac{415}{16}$	$\frac{931}{16}$
$4\frac{3}{4}$	$2\frac{5}{8}$	4.256	.0476	17.721	14.226	$\frac{71}{4}$	$\frac{715}{16}$	$\frac{813}{32}$	$4\frac{3}{4}$	$\frac{415}{16}$	$\frac{1011}{16}$
5	$2\frac{1}{2}$	4.480	.0500	19.635	15.763	$\frac{75}{8}$	$\frac{715}{16}$	$\frac{837}{32}$	5	$\frac{415}{16}$	$\frac{1049}{16}$
$5\frac{1}{4}$	$2\frac{1}{2}$	4.730	.0500	21.648	17.572	8	$\frac{715}{16}$	$\frac{939}{32}$	$5\frac{1}{4}$	$\frac{515}{16}$	$\frac{1123}{16}$
$5\frac{1}{2}$	$2\frac{3}{8}$	4.953	.0526	23.758	19.267	$\frac{83}{8}$	$\frac{815}{16}$	$\frac{933}{32}$	$5\frac{1}{2}$	$\frac{515}{16}$	$\frac{1173}{16}$
$5\frac{3}{4}$	$2\frac{3}{8}$	5.203	.0526	25.967	21.262	$\frac{87}{4}$	$\frac{811}{16}$	$\frac{1037}{32}$	$5\frac{3}{4}$	$\frac{515}{16}$	$\frac{1233}{16}$
6	$2\frac{1}{4}$	5.423	.0555	28.274	23.098	$\frac{97}{8}$	$\frac{915}{16}$	$\frac{1032}{32}$	6	$\frac{515}{16}$	$\frac{1213}{16}$

The term "machine screws" covers many forms of small screws, usually with screw-driver heads. All of the kinds given in this classification are made in great variety of size, form, length, etc.

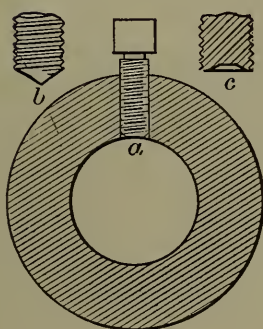

FIG. 77.

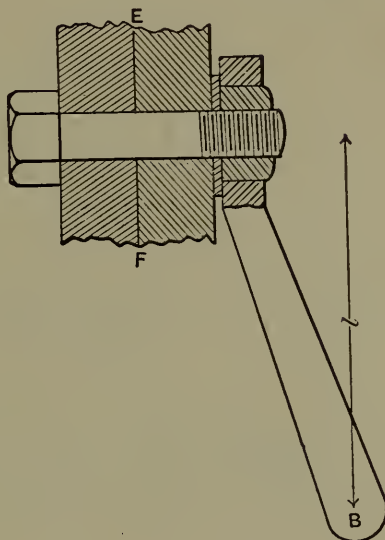

FIG. 78.

Thus far American manufacturers have failed to agree upon standard dimensions for set-screws and machine screws.

For consideration of their design, we will divide bolts and screws into three classes:

- (a) Those which are put under no stress by screwing up.
- (b) Those which are put under an initial stress by tightening.
- (c) Those which are used to transmit power.

87. Analysis of Action of Screw.—Before taking these cases up in detail it will be well to examine into the general action of screw and nut. Reference is made to Fig. 79. The turning of a nut loaded with W lbs. may be considered as equivalent to moving a load W on an inclined plane whose angle with the horizontal is the same as the mean pitch angle of the thread α .

Let r_1 = outside radius of thread;

r_2 = inside radius of thread;

r = mean radius of thread, approximately $\frac{r_1 + r_2}{2}$;

p = pitch of thread;

α = mean pitch angle, *i.e.*, $\tan \alpha = \frac{p}{2\pi r}$;

μ = coefficient of friction between nut and thread;

ϕ = angle of friction between nut and thread, *i.e.*, $\tan \phi = \mu$.

1st. To raise W .

Consider W as a free body moving uniformly up the incline under the system of forces shown in Fig. 80, where W = axial

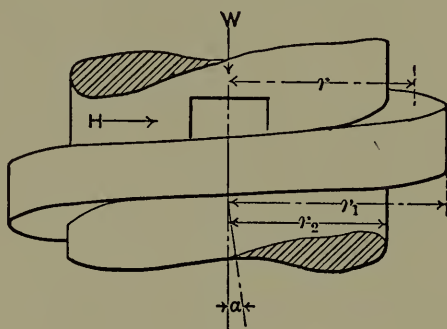

FIG. 79.

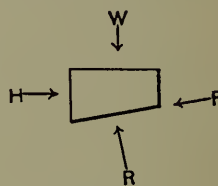

FIG. 80.

load, R the normal reaction between nut and thread due to W , H the horizontal push forcing the nut up the incline, and F the friction in direction of incline due to the normal pressure R ; then, by the ordinary laws of mechanics,

$$R = W \div \cos \alpha, \quad \dots \dots \dots (1)$$

$$F = \mu W \div \cos \alpha, \quad \dots \dots \dots (2)$$

$$H = W \tan (\alpha + \phi). \quad \dots \dots \dots (3)$$

The turning moment M

$$= Hr = Wr \tan (\alpha + \phi). \quad \dots \dots \dots (4)$$

Since $\tan \alpha = \frac{p}{2\pi r}$, and $\tan \phi = \mu$, while

$$\tan(\alpha + \phi) = \frac{\tan \alpha + \tan \phi}{1 - \tan \alpha \tan \phi},$$

it follows that

$$M = Hr = Wr \frac{p + 2\pi r \mu}{2\pi r - p\mu} \dots \dots \dots (5)$$

2d. To lower W ,

$$H = W \tan (\alpha - \phi), \dots \dots \dots (6)$$

$$M = Hr = Wr \frac{p - 2\pi r \mu}{2\pi r + p\mu} \dots \dots \dots (7)$$

The foregoing has applied to square threads. Consider V threads with β =the angle of V with a plane normal to the axis of the screw. (See Fig. 81.) The mean helix angle= α as be-

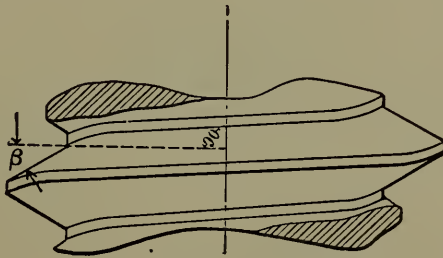

FIG. 81.

fore, but now R slopes from W in two directions, making the angle α in the one, as before, but also making the angle β with W in a plane at right angles with the first. Hence

$$R = W \sec \alpha \sec \beta. \dots \dots \dots (8)$$

$$F = \mu W \sec \alpha \sec \beta. \dots \dots \dots (9)$$

For raising load,

$$Hr = Wr \frac{p + 2\pi r \mu \sec \beta}{2\pi r - p\mu \sec \beta} \dots \dots \dots (10)$$

For lowering load,

$$Hr = Wr \frac{\phi - 2\pi r \mu \sec \beta}{2\pi r + \phi \mu \sec \beta} \dots \dots \dots (11)$$

88. Calculation for Screws Not Stressed in Screwing Up.— Returning now to (a). As illustrations of this class consider the eye-bolts shown in Fig. 82. It is customary to neglect the influence of the thread on the strength of the bolt, and to consider as the effective area, A , to resist stress, only the area of a circle whose diameter equals the diameter of the bolt at the bottom of the thread. In both cases considered a torsional stress is induced by screwing the engaging surfaces together, but if these surfaces are a proper fit, this stress is negligible, particularly since it exists only within the limits of the engaging threads where the action of the further working load which the bolt bears does not come into play.

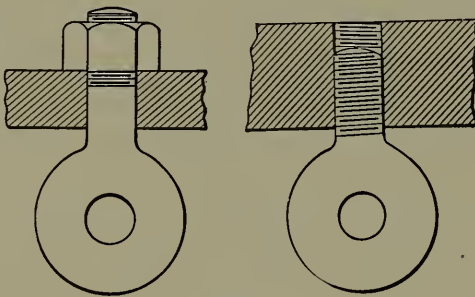

FIG. 82.

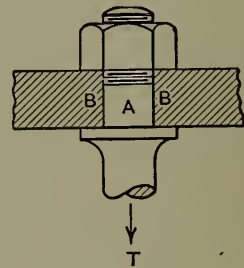

FIG. 83.

The eye-bolt being now subjected to the working load T in the direction of its axis, we have

$$A = \frac{T}{f},$$

where f is the safe unit working stress for the material and conditions.

If U = ultimate unit strength of the material, then, if the

load is a constant, dead load, f may be taken as great as $\frac{U}{3}$ for good wrought iron or mild steel. If the load is a variable one, slowly applied and removed, f should not exceed $\frac{U}{5}$ for the same materials. If the load is variable and suddenly applied, f should never exceed $\frac{U}{10}$ for these materials, and in cases of shock may need to be much smaller than this.

The case shown in Fig. 83 must not be confused with the preceding. Here (as will be explained under (b)) there may be a tensile stress in A induced by compressing $B-B$ between the shoulder and the nut. If the extension in the part A of the bolt due to the application of the force T later be greater than the compression caused in $B-B$ by the tightening of the nut, then the shoulder will leave $B-B$, and simple tension $= T$ results in all sections of the bolt below the nut, as in case (a).

On the other hand, if the extension in the part A of the bolt due to the subsequent application of T be not so great as the original compression of $B-B$ due to the screwing up, then we have in the part A a resultant tension greater than T . This case would come under (b).

89. Calculation of Screws Stressed in Screwing Up.—(b) Combined tension and torsion are induced in a bolt by tightening it. The stress may equal, or very greatly exceed, the tensile stress due to working forces. Consider the example shown in Fig. 78. Suppose the nut screwed down so that the parts connected by the bolt are held close together at $E-F$ but have not yet been compressed. Suppose that the proportions are such that the wrench may be given another complete turn. The nut will move along the direction of axis of the bolt a distance $= p$. The parts held between the head and nut will be compressed and the body of the bolt will be extended.

The force applied at the point B , or end of the wrench (a distance l from the axis) will range from a value of 0 at the beginning of the turn to a value P at the finish. The average value of the turning force will be approximately $=\frac{P}{2}$.

This distance moved through by the point of application of the force is $2\pi l$. Hence the work done in turning the nut a full turn under these conditions will be

$$\frac{P}{2} \cdot 2\pi l = P\pi l. \quad \dots \dots \dots (12)$$

The resistances overcome by this application of energy are three in number:

- 1st. The work done in extending the bolt.
- 2d. The work done in overcoming the frictional resistance between nut and thread.
- 3d. The work done in overcoming the frictional resistance between nut and washer.

These will be considered in order.

1st. Let T = the final pure tensile stress in the bolt due to screwing up one turn. At the beginning of the turn the tension = 0. The average value may be considered $=\frac{T}{2}$ for the turn. The distance moved through by the point of application of this force in the direction of its line of action, in one turn = p . The work done in extending the bolt

$$= \frac{T}{2} p. \quad \dots \dots \dots (13)$$

2d. The frictional resistance between the threads of nut and bolt depends upon the form of the thread as well as the materials used and the condition of the surfaces. (See equations (2)

and (9), § 87.) Assuming a V thread as being more commonly used for fastenings, the average value of the friction

$$F = \mu \frac{T}{2} \sec \alpha \sec \beta$$

(eq. (9)), since the average load for the turn = $\frac{T}{2}$.

The distance moved through by the point of application of F for one turn of the nut on the bolt = $p \operatorname{cosec} \alpha$. Hence the work done in overcoming the friction between bolt and nut in

the one turn = $\mu \frac{T}{2} \sec \alpha \sec \beta \cdot p \operatorname{cosec} \alpha$

$$= \frac{T}{2} \mu p \sec \alpha \sec \beta \cdot \operatorname{cosec} \alpha. \quad \dots \quad (14)$$

3d. The frictional resistance between nut and washer due to a mean force $\frac{T}{2}$ will be $\mu' \frac{T}{2}$, in which μ' is the coefficient of friction between nut and washer. The point of application of this resistance may be taken at a distance of $\frac{3}{2}r_1$ from the axis of the bolt, r_1 being the outside radius of bolt-thread. The distance moved through by the point of application for one turn of the nut = $2\pi \frac{3}{2}r_1$, and the work done in overcoming this frictional resistance

$$= \frac{T}{2} \mu' 3\pi r_1. \quad \dots \quad (15)$$

Equating (12) to the sum of (13), (14), and (15), gives

$$P\pi l = \frac{T}{2} p + \frac{T}{2} \mu p \sec \alpha \sec \beta \operatorname{cosec} \alpha + \frac{T}{2} \mu' 3\pi r_1,$$

whence

$$T = \frac{2P\pi l}{p + \mu p \sec \alpha \sec \beta \operatorname{cosec} \alpha + \mu' 3\pi r_1} \dots \dots \dots (16)$$

$$f_t = \frac{T}{A} = \text{unit stress in bolt due to pure tension.} \dots \dots \dots (17)$$

In addition to this it must be borne in mind that the screw is subjected to a torsional moment whose value can be determined by considering the nut as a free body as shown in plan view in Fig. 84, where all of the forces capable of producing moments about the axis of the nut are indicated as they exist at the end of the turn.

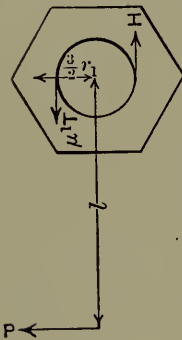

FIG. 84.

Summing the moments about the axis of the bolt gives

$$Hr = Pl - \mu' T \frac{3}{2} r_1 \dots \dots \dots (18)$$

Hr is, of course, the torsional moment transmitted from the nut to the bolt. To find its numerical value substitute the value of T found in equation (16) and solve (18).

The unit stress induced in the outer fibers of a rod of circular section and radius r_2 (=radius at bottom of thread) is found by means of the equation

$$f_s \frac{J}{c} = M \dots \dots \dots (19)$$

J is the polar moment of inertia, in this case $= \frac{\pi r_2^4}{2}$; c is the distance from neutral axis to most strained fiber, in this case $= r_2$; f_s is the induced unit stress in outer fiber; M is the moment, in this case $= Hr$. Combining equations (18) and (19) and substituting these values gives

$$f_s = \frac{2(Pl - \mu' T \frac{3}{2} r_1)}{\pi r_2^3} \dots \dots \dots (20)$$

The equivalent tensile unit stress due to the combined action of f_t and f_s is found from the equation for combined tension and torsion,

$$f = 0.35f_t + 0.65\sqrt{f_t^2 + 4f_s^2}. \quad \dots \quad (21)$$

90. Problem.—What is the unit fiber stress induced in a U. S. standard $\frac{1}{2}$ -inch bolt in screwing up the nut with a pull of one pound at the end of a wrench 8 inches long? Arrangement of parts as shown in Fig. 78.

In this case $d_1 = .500$ in., $r_1 = .25$ in.,

$$\begin{aligned} d_2 &= .400 \text{ in.}, & r_2 &= .2 \text{ in.}, \\ r &= .225 \text{ in.}, & A &= .126 \text{ sq. in.}, \\ p &= .077 \text{ in.}, \\ \mu &= \mu' = 0.15, \end{aligned}$$

$\alpha =$ angle whose tangent is $\frac{p}{2\pi r} = 3^\circ 7'$,

$$\begin{aligned} \sec \alpha &= 1.0015, & \operatorname{cosec} \alpha &= 18.39, \\ \beta &= 30^\circ, & \sec \beta &= 1.155, \\ P &= 1 \text{ lb.}, & \text{and } l &= 8 \text{ ins.} \end{aligned}$$

From equation (16)

$$\begin{aligned} T &= \frac{2 \times 1 \times \pi \times 8}{.077 + .077 \times 0.15 \times 1.0015 \times 1.155 \times 18.39 + 0.15 \times 3 \times \pi \times 0.25} \\ &= 74.467 \text{ lbs.} \end{aligned}$$

From equation (17),

$$f_t = \frac{74.467}{.126} = 591 \text{ lbs.}$$

From equation (20),

$$\begin{aligned} f_s &= \frac{2(1 \times 8 - 0.15 \times 74.467 \times \frac{3}{2} \times 0.25)}{\pi \times 0.225^3} \\ &= 213 \text{ lbs.} \end{aligned}$$

From equation (21),

$$f = 0.35 \times 591 + 0.65 \sqrt{591^2 + 4 \times 213^2}$$

$$= 691.4 \text{ lbs.}$$

If a pull of one pound on an 8-inch wrench applied to a $\frac{1}{2}$ -inch bolt can induce a unit fiber stress of 691.4 lbs., since equations (16) and (20) show that the stress increases directly as the pull, it follows that a pull of 30 lbs., such as is readily exerted by a workman, will induce a stress of $30 \times 691.4 = 20,742$ lbs. per square inch.

91. Wrench Pull.—If this turning up be gradual and the bolt is not subjected to working stresses, this would be safe for either wrought iron or mild steel. On the other hand, if the final turning be done suddenly by means of a jerking motion or a blow, or a long wrench be used, or even an extra-strong gradual pull be exerted, there is evident danger of f having a value beyond the elastic limit of the material, even reaching the ultimate strength.

It will be noticed also that the torsional action increases the fiber stress over that due to pure tension in the ratio of $\frac{691.4}{591}$, *i.e.*, in this problem, an increase of over 17. per cent. In general this increase will be from 15 to 20 per cent, depending chiefly upon the relation existing between μ and μ' . It should also be noted that the pure tension, T , induced in the bolt by the moment Pl may be taken as the measure of the pressure existing between the surfaces $E-F$ (Fig. 78). In our problem this pressure, for $P = 30$ lbs., would become $30 \times 74.467 = 2234$ lbs.

As a general rule the length of wrench used by the workman is fifteen or sixteen times d_1 , the diameter of bolt, and it may be stated that $T = 75P$ for U. S. standard threads.

92. Calculation of Bolts Subject to Elongation.—Next consider the case shown in Fig. 85. Suppose that the nut is screwed up with a resulting tensile stress in the bolt $=T$. A working force Q tends to separate the bodies A and B at $C-D$. Assume that Q acts axially along the bolt. The question is, What value may Q have without opening the joint $C-D$?

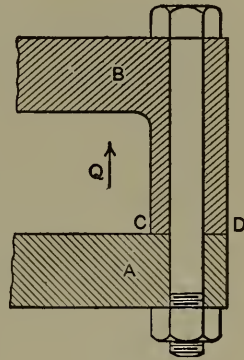

FIG. 85.

- A is the cross-sectional area of the bolt;
- L is the original length between bolt-head and nut when A and B are just in contact at $C-D$ but not compressed;
- T_0 is the tensile stress in bolt due to screwing up;
- λ is the total elongation of bolt due to T_0 ;
- E is the coefficient of elasticity of the bolt material.

Then, since $\frac{\text{unit strain}}{\text{unit stress}} = \frac{1}{E}$, it follows that

$$\frac{\frac{\lambda}{L}}{\frac{T_0}{A}} = \frac{1}{E} \dots \dots \dots (1)$$

- In any given case this can be solved for λ .
- Let A' be the area of A and B compressed by the bolt action;
- λ' is the total compression (*i.e.*, shortening) of A and B , due to the tightening of the bolt;
- C_0 is the total compressive stress which produces λ' ;

$$\therefore C_0 = T_0.$$

E' is the coefficient of elasticity of the material A, B . Then

$$\frac{\frac{\lambda'}{L}}{\frac{C_0}{A'}} = \frac{1}{E'} \dots \dots \dots (2)$$

This can be solved for λ' .

Now consider the condition when a working force, Q , acts tending to elongate the bolt so that A and B will just be ready to separate at $C-D$. In order that this separation may begin, the bolt, already elongated an amount λ , must be elongated a further amount λ' .

For incipient separation the total elongation of the bolt then $=\lambda+\lambda'$, and the total stress in the bolt corresponding to this elongation, $=T'$, can be determined from the equation

$$\frac{\frac{\lambda + \lambda'}{L}}{\frac{T'}{A}} = \frac{1}{E} \dots \dots \dots (3)$$

Considering the bolt-head as a free body (Fig. 86), it follows



that the forces acting on it at any instant will be, C , the reaction of the material of A due to its resistance to compression; Q , the working force; and T , the tension in the bolt. Hence

$$T = C + Q \dots \dots \dots (4)$$

When the bolt is first screwed up, and $Q = 0$, then $C = T$, and $T = T_0$, the tension due to screwing up. When Q comes into action, C is partly relieved, and when Q reaches such a value that the surfaces are about to part, then $C = 0$ and $Q = T = T'$. (See equation (3).)

An examination of these formulæ shows certain facts which may be stated as follows: The tightness of the joint $C-D$ depends upon the compressibility of A and B .

Anything which increases the total compression, λ' , increases the tightness of the joint. This may be accomplished by increasing L or C_0 , or decreasing A' . It may also be increased

by the introduction of a highly elastic body (*i.e.*, gasket) between *A* and *B*.

It also follows that the tension in the bolt when the joint is about to open, T' , must be greater than the tension due to screwing up, T_0 , and therefore if Q be limited to a value equal to or less than T_0 , there will be no opening of the joint. In general, A' is large compared with A , and λ' very small compared with λ , so that T' is not much greater than T_0 . In order to be sure of a tight joint the initial tension should be taken $T_0 = 2Q$.

93. **Problem I.**—Calculate the bolts for a “blank” end for a 6-inch pipe using flanged couplings with ground joints, and no gaskets, as shown in Fig. 87. The excess internal pressure is to be 150 lbs. per square inch.

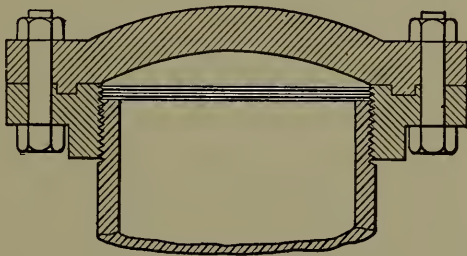

FIG. 87.

The area subjected to pressure has a diameter of $7\frac{1}{2}$ ins.; hence the total working pressure = $150 \times \frac{\pi \times 7.5^2}{4} = 6627$ lbs.

The number of bolts is determined by the distance they may be spaced apart without danger of leakage due to the springing of the flange between the bolts. This distance may be taken equal to four or five times the thickness of the flange. In the problem under consideration, the diameter of the bolt circle will be approximately 9 ins., and using six bolts, the chord length between consecutive ones will be about $4\frac{1}{2}$ ins., which is perfectly safe.

With six bolts

$$Q = \frac{6627}{6} = 1105 \text{ lbs.}$$

Take $T_0 = 2Q = 2210 \text{ lbs.}$

With a direct tension of 2210 lbs. due to screwing up, there is also the stress due to torsion. As stated in § 91, this may increase the fiber stress 20 per cent over that due to direct tension. To allow for this the bolts used must be capable of safely sustaining a stress of $2210 \times 1.20 = 2650 \text{ lbs.}$

The allowable unit stress here may be taken rather high, since the conditions after once screwing up approximate a steady load. Assume steel bolts with an allowable unit stress of 15,000 lbs.

The area of each bolt at the bottom of the thread will then be $\frac{2650}{15000} = 0.177 \text{ sq. in.}$ This value lies between a $\frac{9}{16}$ -inch and a $\frac{5}{8}$ -inch bolt. Select the latter with an area of 0.202 sq. in. To exert an initial tension of 2250 lbs. in a $\frac{5}{8}$ -inch bolt would require a pull of about 30 lbs. on a 10-inch wrench. (See § 91.) These values just about correspond to actual conditions in practice.

94. Problem II.—It is required to design the fastenings to hold on the steam-chest cover of a steam-engine. The opening to be covered is rectangular, $10'' \times 12''$. The maximum steam-pressure is 100 lbs. per square inch. The joint must be held steam-tight. Studs of machinery steel having an ultimate tensile strength of 60,000 lbs. per square inch will be used.

The total working pressure = $10 \times 12 \times 100 = 12,000 \text{ lbs.}$

The number of studs to be used will be governed by the distance they may be spaced without springing of the cover. The thickness of the latter being assumed to be $\frac{3}{4}$ inch at the edge, the spacing should not exceed $5'' \times \frac{3}{4}'' = 1\frac{5}{4}''$, say 4 inches.

The opening is $10'' \times 12''$, as shown in Fig. 88. There must be a band about $\frac{5}{8}$ or $\frac{3}{4}$ inch wide around this for making the joint, upon which the studs must not encroach. This makes the distance between the centers of the vertical rows of studs about 14 inches, and between the horizontal rows about 12 inches. Twelve studs can be used if arranged as shown in the figure. The greatest distance, that between the studs across the corners, will but slightly exceed the allowable 4 inches.

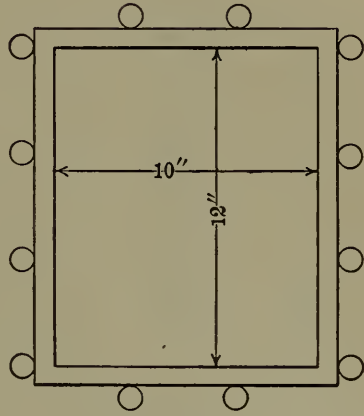

FIG. 88.

With 12 studs, the working load on each = $Q = \frac{12000}{12} = 1000$ lbs.

$$T_0 = 2Q = 2000 \text{ lbs.}$$

Allowing 20 per cent for torsional stress, increase this to 2400 lbs.

Allowing a unit stress of 15,000 lbs., as in Problem I, we have as the area of the stud at the bottom of thread $\frac{2400}{15000} = 0.160$.

This corresponds to a $\frac{9}{16}$ -inch stud. Since a workman may readily stress a bolt of this size beyond the elastic limit by exerting too great a pull in tightening, many designers would increase these studs to $\frac{5}{8}$ inch or even $\frac{3}{4}$ inch.

95. Design of Bolts for Shock.—The elongation of a bolt with a given total stress depends upon the LENGTH and AREA of its least cross-section. Suppose, to illustrate, that the bolt, Fig. 89, has a reduced section over a length l as shown. This portion, A , has less cross-sectional area than the rest of the bolt, and when any tensile force is applied, the resulting UNIT stress will be greater in A than elsewhere. The unit strain, or elongation, will be proportionately greater up to the elastic limit; and

if the elastic limit is exceeded in the portion *A*, the elongation there will be far greater than elsewhere. If there is much differ-

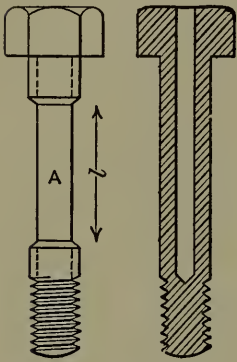

FIG. 89. FIG. 90.

ence of area and the bolt is tested to rupture, the elongation will be chiefly at *A*. There would be a certain elongation PER INCH of *A* at rupture. Hence the greater the length of *A*, the greater the total elongation of the bolt. If the bolt had not been reduced at *A*, the minimum section would be at the root of the screw-threads. The axial length of this section is very small.

Hence the elongation at rupture would be small. Suppose there are two bolts, *A* with and *B* without the reduced section. They are alike in other respects. They are subjected to equal tensile shocks. Let the energy of the shock = E . This energy is divided into force and space factors by the resistance of the bolts. The space factor equals the elongation of the bolt. This is greater in *A* than in *B*, because of the yielding of the reduced section. But the product of force and space factors is the same in both bolts, = E ; hence the resulting stress in the minimum section is less for *A* than for *B*. The stress in *A* may be less than the breaking stress, while the greater stress in *B* may break it. THE CAPACITY OF THE BOLT TO RESIST SHOCK IS THEREFORE INCREASED BY LENGTHENING ITS MINIMUM SECTION TO INCREASE THE YIELDING AND REDUCE STRESS. This is not only true of bolts, but of all stress members in machines.

The whole body of the bolt might have been reduced, as shown by the dotted lines in Fig. 89, with resulting increase of capacity to resist shock. Turning down a bolt, however, weakens it to resist torsion and flexure, because it takes off the material which is most effective in producing large polar and rectangular moments of inertia of cross-section. If the cross-sectional area is reduced by drilling a hole, as shown in Fig. 90, the torsional

and transverse strength is but slightly decreased, but the elongation will be as great with the same area as if the area had been reduced by turning down.

Professor Sweet had a set of bolts prepared for special test. The bolts were $1\frac{1}{4}$ inches diameter and about 12 inches long. They were made of high-grade wrought iron, and were duplicates of the bolts used at the crank end of the connecting-rod of one of the standard sizes of the Straight-line Engine. Half of the bolts were left solid, while the other half were carefully drilled to give them uniform cross-sectional area throughout. The tests were made under the direction of Professor Carpenter at the Sibley College Laboratory. One pair of bolts was tested to rupture by tensile force gradually applied. The undrilled bolt broke in the thread with a total elongation of 0.25 inch. The drilled bolt broke between the thread and the bolt-head with a total elongation of 2.25 inches. If it be assumed that the mean force applied was the same in both cases, it follows that the total resilience of the drilled bolt was nine times as great as that of the solid one. "Drop tests," *i.e.*, tests which brought tensile shock to bear upon the bolts, were made on other similar pairs of bolts, which tended to confirm the general conclusion.

96. Problem.—It is required to design proper fastenings for holding on the cap of a connecting-rod like that shown in Fig. 91. These fastenings are required to sustain shocks, and may be subjected to a maximum accidental stress of 20,000 lbs. There are two fastenings, and therefore each must be capable of sustaining safely a stress of 10,000 lbs. They should be designed to yield as much as is consistent with strength; in other words, they should be tensile springs to cushion shocks, and thereby reduce the resulting force they have to sustain. Bolts

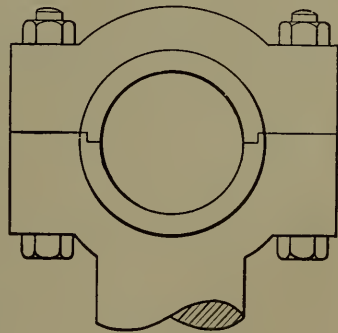

FIG. 91.

should therefore be used, and the weakest section should be made as long as possible. Wrought iron will be used whose tensile strength is 50,000 lbs. per square inch. The stress given is the maximum accidental stress, and is four times the working stress. It is not, therefore, necessary to give the bolts great excess of strength over that necessary to resist actual rupture by the accidental force. Let the factor of safety be 2. This will keep the maximum fiber stress within the elastic limit. Then the cross-sectional area of each bolt must be such that it will just sustain $10,000 \times 2 = 20,000$ lbs. This area is equal to $20,000 \div 50,000 = 0.4$ sq. in. This area corresponds to a diameter of 0.71 inch, and that is nearly the diameter of a $\frac{7}{8}$ -inch bolt at the bottom of the thread; hence $\frac{7}{8}$ -inch bolts will be used. The cross-sectional area of the body of the bolt must now be made at least as small as that at the bottom of the thread. This may be accomplished by drilling.

97. Jam-nuts.—When bolts are subjected to constant vibration there is a tendency for the nuts to loosen. There are many ways to prevent this, but the most common one is by the use of jam-nuts. Two nuts are screwed on the bolt; the under one is set up against the surface of the part to be held in place, and then while this nut is held with a wrench the other nut is screwed up against it tightly. Suppose that the bolt has its axis vertical and that the nuts are screwed on the upper end. The nuts being screwed against each other, the upper one has its internal screw surfaces forced against the under screw surfaces of the bolt, and if there is any lost motion, as there almost always is, there will be no contact between the upper surfaces of the screw on the bolt and the threads of the nut. Just the reverse is true of the under nut; *i.e.*, there is no contact between the under surfaces of the threads on the bolt and the threads on the nut. Therefore no pressure that comes from the under side of the under nut can be communicated to the bolt through the under nut

directly, but it must be received by the upper nut and communicated by it to the bolt, since it is the upper nut alone that has contact with the under surfaces of the thread. Therefore the jam-nut, which is usually made about half as thick as the other, should always be put on next to the surface of the piece to be held in place.

98. Calculation of Screws for Transmission of Power.—

(c) Screws are frequently used to transmit power. A screw-press is a common example, while the action of spiral gears, including worms and wheels, is that of screws and subject to the same analysis.

The general action of screw and nut has already been treated. (See § 87.)

With a square-thread screw it was found that the moment $Pl = M$, required to raise a load W , will be $= Wr \frac{p + 2\pi r \mu}{2\pi r - p \mu}$ (5) (page 171).

This will induce a fiber stress $f_s = \frac{c(Pl)}{J}$ (see equation (19)), which must be combined with the tension, $f_t = \frac{W}{A}$, in order to get the actual unit stress, f , remembering

$$f = .35f_t + .65\sqrt{f_t^2 + 4f_s^2}. \quad \dots \quad (21)$$

Let n = number of complete thread surfaces in contact between the nut and screw, and the projected area equals $\frac{\pi}{4}(d_1^2 - d_2^2)$ to bear the load W .

$$W = Kn \frac{\pi}{4} (d_1^2 - d_2^2),$$

where K is the allowable pressure per square inch of projected thread area.

For nuts and bolts which are used as fastenings we may take:
 $K = 2500$ lbs. for wrought or cast iron running on the same material or on bronze;

$K = 3000$ lbs. for steel on steel or bronze.

With good lubrication, where the screw and nut are used to transmit power, we may take the values given in the following table:

TABLE VII.

Rubbing Speed in Feet per Minute.	Value of K .	
	Iron.	Steel.
50 or less.	2500	3000
100.	1250	1500
150.	850	1000
250.	400	500
400.	200	250

The value of μ has been experimentally determined by Professor Kingsbury.* He concludes that for metallic screws turning at extremely slow speeds, under any pressure up to 14,000 lbs. per square inch of bearing surface, and freely lubricated before application of the pressure, the following coefficients of friction may be used.

TABLE VIII.

Lubricant.	μ .
Lard-oil.	0.11
Heavy-machinery oil (mineral).	0.143
Heavy-machinery oil and graphite in equal volumes.	0.07

Regarding the efficiency of the square-screw thread to transmit energy, we may reason as follows:

$$\text{The efficiency} = e = \frac{\text{useful work}}{\text{total work}}$$

* Transactions A. S. M. E., Vol. XVII, pp. 96-116.

which becomes for one turn $= \frac{Wp}{2\pi rH}$.

$$\frac{Wp}{2\pi rH} = \frac{W \frac{p}{2\pi r}}{H} = \frac{W \tan \alpha}{W \tan (\alpha + \phi)} = \frac{\tan \alpha}{\tan (\alpha + \phi)} \dots (22)$$

From this it appears that e becomes 0, for $\alpha = 0^\circ$ and for $\alpha = 90^\circ - \phi$, and must therefore have a maximum value between these limits. To determine this maximum, write

$$\frac{\tan \alpha}{\tan (\alpha + \phi)} = \tan \alpha \cot (\alpha + \phi).$$

Taking the first differential and equating to 0,

$$\frac{\cot (\alpha + \phi)}{\cos^2 \alpha} - \frac{\tan \alpha}{\sin^2 (\alpha + \phi)} = 0.$$

Solving which gives

$$\alpha = 45^\circ - \frac{\phi}{2}.$$

To find the corresponding value of e , write (from (22))

$$\text{max. } e = \frac{\tan \left(45^\circ - \frac{\phi}{2} \right)}{\tan \left(45^\circ - \frac{\phi}{2} + \phi \right)} = \frac{\tan \left(45^\circ - \frac{\phi}{2} \right)}{\tan \left(45^\circ + \frac{\phi}{2} \right)}.$$

To lower W with a square-threaded screw,

$$Pl = Hr = Wr \frac{p - 2\pi r \mu}{2\pi r + p\mu} \dots \dots \dots (23)$$

[The value of f_s can be found from this, as explained in the section on raising W , and combined with f_t to obtain f_j .]

Regarding the efficiency in this case,

- if $\alpha < \phi$ the load will not sink of itself (*i.e.*, overhaul),
- if $\alpha = \phi$ we have a condition of equilibrium,
- if $\alpha > \phi$ the load will sink of itself (*i.e.*, overhaul).

For a screw which will not overhaul it becomes evident that the limiting value of α is ϕ and the maximum efficiency

$$e = \frac{\tan \alpha}{\tan (\alpha + \phi)} = \frac{\tan \phi}{\tan 2\phi} = \frac{1 - \tan^2 2\phi}{2} = 0.5 - 0.5 \tan^2 2\phi.$$

The efficiency of a screw which will not overhaul can therefore never exceed 0.5 or 50 per cent.

For V threads, with β = angle of V, with a plane normal to the axis of the screw for raising load,

$$Pl = Wr \frac{\phi + 2\pi r \mu \sec \beta}{2\pi r - \phi \mu \sec \beta}, \quad \dots \dots \dots (24)$$

which is evidently greater than (5), and

$$e = \frac{\tan \alpha (1 - \mu \tan \alpha \sec \beta)}{\tan \alpha + \mu \sec \beta}, \quad \dots \dots \dots (25)$$

which is evidently less than e for square threads. (See equation (22).)

It is clear, then, that square threads should be used in preference to V threads for screws for power transmission.

For lowering the load with V threads

$$Pl = Hr = Wr \frac{\phi - 2\pi r \mu \sec \beta}{2\pi r + \phi \mu \sec \beta}. \quad \dots \dots \dots (26)$$

99. Problem.—Design a screw to raise 20,000 lbs. The screw must not overhaul.

What moment need be exerted to lift the load?

What will be the efficiency of the screw?

Select a square-thread screw of machinery steel running in a bronze nut.

For a screw which will not overhaul α must be less than ϕ .

$$\therefore \tan \alpha < \mu.$$

To be safe against overhauling with the materials used and good lubrication, μ must not be given a greater value than 0.10.

$$\therefore \alpha < 5^\circ 45' \quad \text{and} \quad \phi = 5^\circ 45'.$$

The pure tension = 20,000 lbs. = W . In the preliminary calculations, to allow for the effect of torsion, this will be increased

$$\text{so that } f = \frac{25000}{A}.$$

In this equation f is the allowable unit stress in pounds per square inch, and A is the area of the screw at the bottom of the thread in square inches.

Assume that this screw is frequently loaded and unloaded, and not subject to shocks nor reversal of stress so that $f = 12,000$ lbs. per square inch for mild steel. Then $A = \frac{25000}{12000} = 2.08$ sq. ins. This corresponds to a diameter of $1\frac{5}{8}$ inches at bottom of thread.

From $\tan \alpha = \frac{p}{2\pi r}$, we have

$$p = 2\pi r \tan \alpha.$$

Remembering that for square threads the depth of the thread = $\frac{p}{2}$, and that r_2 is the radius at the bottom of thread, and

$$\therefore r = r_2 + \frac{p}{4}, \text{ it follows that}$$

$$p = 2\pi \left(r_2 + \frac{p}{4} \right) \tan \alpha,$$

$$p - \frac{2\pi \tan \alpha}{4} p = 2\pi r_2 \tan \alpha,$$

$$p = \frac{2\pi r_2 \tan \alpha}{1 - \frac{\pi}{2} \tan \alpha}.$$

$$\therefore p = \frac{2 \times \pi \times 0.8125 \times 0.1}{1 - 1.57 \times 0.1} = .606 \text{ inch.}$$

This is not a thread to be easily cut in the lathe. It would be desirable to modify the value of p so that the thread can be readily cut. It is obvious that p cannot be increased without increasing r proportionately, else α will have a greater value than is allowable. It will be more economical to reduce p . The nearest even value would be $\frac{1}{2}$ inch, and this will be selected.

Check this for strength:

$$d_2 = 1.625 \text{ inches, } r_2 = 0.8125 \text{ inch, } p = 0.5 \text{ inch.}$$

$$d_1 = 2.125 \text{ inches, } r_1 = 1.0625 \text{ inches,}$$

$$d = 1.875 \text{ inches, } r = 0.9375 \text{ inch,}$$

$$\tan \alpha = \frac{p}{2\pi r} = \frac{0.5}{2 \times \pi \times 0.9375} = 0.087,$$

which is safe, as it is less than the value of $\mu = 0.10$.

From equation (5), the moment,

$$Pl = Hr = Wr \frac{p + 2\pi r \mu}{2\pi r - p \mu}$$

$$\therefore Pl = 20000 \times 0.9375 \frac{0.5 + 2 \times \pi \times 0.9375 \times 0.10}{(2 \times \pi \times 0.9375) - (0.5 \times 0.10)}$$

$$= 3496 \text{ in.-lbs.}$$

From equation (19), the fiber stress due to torsion,

$$j_s = \frac{cPl}{J} = \frac{2Pl}{\pi r_2^3}$$

$$\therefore j_s = \frac{2 \times 3496}{\pi \times 0.8125^3} = 4140 \text{ lbs. per square inch.}$$

From equation (17), the unit stress due to tension,

$$j_t = \frac{W}{A} = \frac{20000}{2.074} = 9597 \text{ lbs. per square inch.}$$

From equation (21), the combined stress,

$$j = 0.35j_t + 0.65\sqrt{j_t^2 + 4j_s^2}$$

$$\begin{aligned} \therefore j &= 0.35 \times 9597 + 0.65\sqrt{9597^2 + 4 \times 4140^2} \\ &= 12,379 \text{ lbs. per square inch,} \end{aligned}$$

which is near enough 12,000 to be considered safe.

The efficiency, from equation (22),

$$e = \frac{\tan \alpha}{\tan (\alpha + \phi)}$$

Since $\tan \alpha = 0.087$, $\alpha = 5^\circ$.

Since $\mu = \tan \phi = 0.10$, $\phi = 5^\circ 45'$.

$$\therefore \alpha + \phi = 10^\circ 45', \quad \tan 10^\circ 45' = 0.1899.$$

$$\therefore e = \frac{0.087}{0.1899} = 0.4581, \text{ or } 45.81\%.$$

The height of the nut is determined from the equation

$$W = Kn \frac{\pi}{4} (d_1^2 - d_2^2),$$

in which W is the load, n the number of complete threads in the nut, d_1 the outside and d_2 the inside diameter of thread. K is the allowable pressure in pounds per square inch, and its value depends upon the speed. See table on page 134.

Assuming the screw to have a rubbing velocity of less than 50 feet per minute, $K = 3000$. Then

$$n = \frac{W}{3000 \frac{\pi}{4} (d_1^2 - d_2^2)} = \frac{20000}{3000 \times 0.7854 (2.125^2 - 1.625^2)}$$

$$= 4.5, \text{ nearly.}$$

$$\text{The height of nut} = p \times n = \frac{1}{2}'' \times 4.5'' = 2\frac{1}{4}''.$$

CHAPTER IX.

MEANS FOR PREVENTING RELATIVE ROTATION.

100. Classification of Keys.—Keys are chiefly used to prevent relative rotation between shafts and the pulleys, gears, etc., which they support. Keys may be divided into parallel keys, taper keys, disk keys, and feathers or splines.

101. Parallel Keys.—For a PARALLEL KEY the “seat,” both in the shaft and the attached part, has parallel sides, and the key simply prevents relative rotary motion. Motion parallel to the axis of the shaft must be prevented by some other means, as by set-screws which bear upon the top surface of the key, as shown in Fig. 92. A parallel key should fit accurately on the sides and loosely at the top and bottom. The following table (IX) for dimensions for parallel keys is from Richards’s “Manual of Machine Construction.”

TABLE IX.

Diameter of shaft = $d = 1$	$1\frac{1}{4}$	$1\frac{1}{2}$	$1\frac{3}{4}$	2	$2\frac{1}{2}$	3	$3\frac{1}{2}$	4
Width of key = $w = \frac{5}{32}$	$\frac{7}{32}$	$\frac{9}{32}$	$\frac{11}{32}$	$\frac{13}{32}$	$\frac{15}{32}$	$\frac{17}{32}$	$\frac{19}{16}$	$\frac{11}{16}$
Height of key = $t = \frac{3}{16}$	$\frac{1}{4}$	$\frac{5}{16}$	$\frac{3}{8}$	$\frac{7}{16}$	$\frac{1}{2}$	$\frac{9}{16}$	$\frac{5}{8}$	$\frac{3}{4}$

Excellent parallel keys are made from cold-rolled steel without need of any machining.

102. Taper Keys.—A TAPER KEY has parallel sides and has its top and bottom surfaces tapered, and is made to fit on all four surfaces, being driven tightly “home.” It prevents relative motion of any kind between the parts connected. If a key of this kind has a head, as shown in Fig. 93, it is called a “draw key,” because it is drawn out when necessary by driving a

wedge between the hub of the attached part and the head of the key. When a taper key has no head it is removed by driving against the point with a "key-drift."

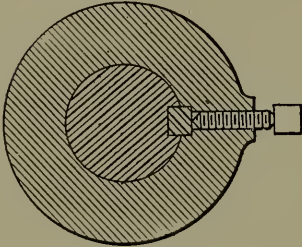

FIG. 92.

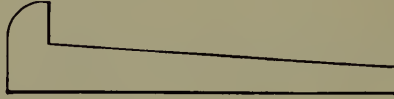

FIG. 93.

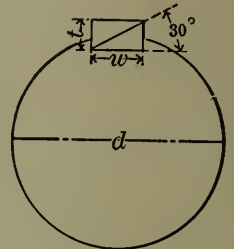

FIG. 94.

John Richards's rule for keys is (see Fig. 94) $w = \frac{d}{4}$. t has such value that $\alpha = 30^\circ$. This rule is deviated from somewhat, as shown by the following table (X) taken from Richards's "Manual of Machine Construction," page 58:

TABLE X.

$d = 1$	$1\frac{1}{4}$	$1\frac{1}{2}$	$1\frac{3}{4}$	2	$2\frac{1}{2}$	3	$3\frac{1}{2}$	4	5	6	7	8
$w = \frac{1}{4}$	$\frac{5}{16}$	$\frac{3}{8}$	$\frac{7}{16}$	$\frac{1}{2}$	$\frac{5}{8}$	$\frac{3}{4}$	$\frac{7}{8}$	1	$1\frac{1}{8}$	$1\frac{3}{8}$	$1\frac{1}{2}$	$1\frac{3}{4}$
$t = \frac{5}{32}$	$\frac{3}{16}$	$\frac{1}{4}$	$\frac{9}{32}$	$\frac{5}{16}$	$\frac{3}{8}$	$\frac{7}{16}$	$\frac{1}{2}$	$\frac{5}{8}$	$\frac{11}{16}$	$\frac{13}{16}$	$\frac{7}{8}$	1

When two or more keys are used, $w = d \div 6$, t being, as before, of such value that α shall = 30° .

The taper of keys varies from $\frac{1}{8}$ to $\frac{1}{2}$ inch to the foot.

103. Fitting Shaft and Hub.—In using taper keys it is customary to bore out the hub slightly larger than the diameter of the shaft so that the wheel may be readily removed after the key is withdrawn. This allowance in diameter should not be greater than that for a running fit, say,

$$A = \frac{\frac{5}{16}D + 0.5}{1000},$$

in which formula A is the difference in diameter between the bore of hub and size of shaft, expressed in decimal parts of an

inch, and D is the nominal diameter of shaft in inches. Where the parts do not have to be taken apart frequently, it is vastly better to use a driving fit, *i.e.*, to bore out the hub smaller than

the diameter of the shaft by an amount $A = \frac{\frac{D}{2} + 0.5}{1000}$ and to use parallel keys.

Where a single taper key is used the effect is to make the wheel and shaft eccentric, as can be seen in Fig. 95. The bearing is limited to two points, A , B , and the connection is unstable for the transmission of power.

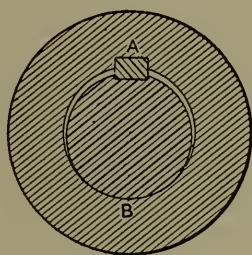

FIG. 95.

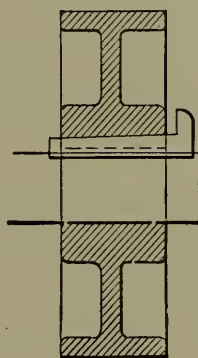

FIG. 96.

If great care is not exercised in having the taper of keyway exactly the same as the taper of the keys, a further difficulty arises in that the wheel will be canted out of a true normal plane to the shaft-axis. This can be seen in Fig. 96.

By using two keys, placed a quarter or third of the circumference apart, a much more stable connection is obtained, as it will give three points of bearing, A , B , and C . (See Fig. 97.) Eccentricity is not avoided by this method.

Another method is that shown in Fig. 98. Here the hub is bored out somewhat larger than the shaft and a bushing B is used opposite the key. This bushing has its outside diameter exactly the diameter of the bore, and its inner diameter exactly

the diameter of the shaft, and it surrounds slightly less than half the shaft. When the key is driven home this insures the

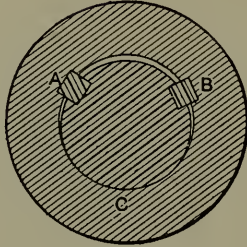

FIG. 97.

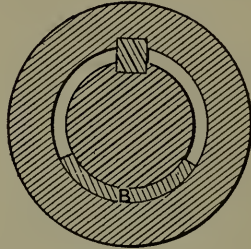

FIG. 98.

wheel and shaft being concentric, but extra care must be taken that key and keyway have precisely the same taper. Three keys uniformly spaced around the shaft also give a means of making the wheel and shaft concentric. This method is rarely used.

104. Woodruff Keys.—The Woodruff or disk system of keys is used by some manufacturers. The key is a half disk, as can be seen in Fig. 99. Under this system the keyway is cut longitudinally in the shaft by means of a milling-cutter. This cutter corresponds in thickness to the key to be inserted, and is of

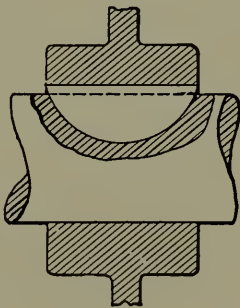

FIG. 99.

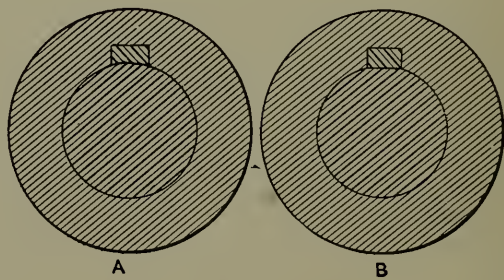

FIG. 100.

a diameter corresponding to the length of the key. The key being semicircular, it is sunk into the shaft as far as will allow sufficient projection of the key above the surface to engage the keyway in the hub.

Owing to its peculiar shape the key may be slightly inclined, so that it will serve to support the wheel on a vertical shaft, provided the key-seat in the hub is made tapering and of the proper depth.

105. Saddle and Flat Keys.—Saddle keys (Fig. 100, *A*) and keys on flats (Fig. 100, *B*) are used occasionally. They have not the holding power of sunk keys.

105. Strength of Sunk Keys.—The strength of the latter is the measure of their holding power. A key of width = w , thickness = t , length = l , unit shearing strength = f_s , and unit crushing resistance = f_c will have a shearing strength = $f_s w l$ and a crushing resistance $f_c \frac{1}{2} t l$.

If r = radius of the shaft, the moment which the key can resist will be measured by $r w l f_s$ or $\frac{1}{2} r t l f_c$, whichever is smaller in value.

All dimensions being expressed in inches and resistance in pounds per square inch, the moments will, of course, be expressed in inch-pounds. Experiments made by Professor Lanza indicate that the ultimate value for f_s for cast iron = 30,000 lbs., for wrought iron = 40,000 lbs., and for machinery steel = 60,000 lbs. A factor of safety of 2 would be advisable with these values.

106. Feathers or Splines are keys that prevent relative rotation, but purposely allow axial motion. They are sometimes made fast in the shaft, as in Fig. 101, and there is a key "way" in the attached part that slides along the shaft. Sometimes the feather is fastened in the hub of the attached part, as shown in Fig. 102, and slides in a long keyway in the shaft.

It is frequently undesirable to have the feather loose. In such cases it is common to use tit-keys as shown in Fig. 103. The keys may be fastened to either hub or shaft. The tits are forged on the keys. Corresponding holes are drilled and countersunk in the piece to which the key is to be fastened,

and after the key is placed in position the ends of the tits are riveted over to hold it securely in place.

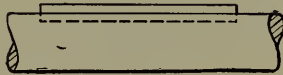

FIG. 101.

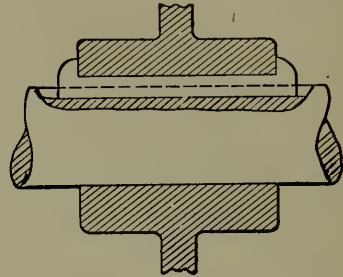

FIG. 102.

Machine screws are sometimes used in place of tits, but they suffer from the disadvantage of jarring loose.

A satisfactory way of holding a key in a hub is shown in Fig. 104.

Where the end of a stud is to receive change-gears a convenient form of key is the dovetail shown in Fig. 105 in cross-

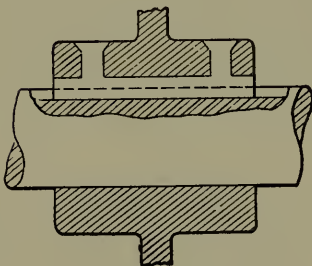

FIG. 103.

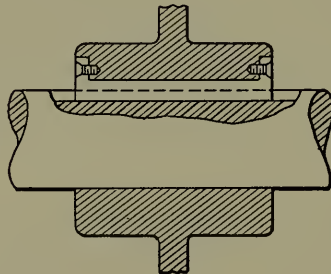

FIG. 104.

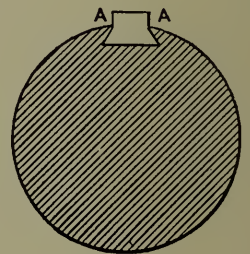

FIG. 105.

section. The dovetailed key-seat is generally cut with a milling-cutter, and is made a tight fit for the key. After the latter is in place the shaft is calked against it at *A-A*.

For feathers, Richards gives:

TABLE XI.

$d = 1\frac{1}{4}$	$1\frac{1}{2}$	$1\frac{3}{4}$	2	$2\frac{1}{4}$	$2\frac{1}{2}$	3	$3\frac{1}{2}$	4	$4\frac{1}{2}$
$w = \frac{1}{4}$	$\frac{1}{4}$	$\frac{5}{16}$	$\frac{5}{16}$	$\frac{3}{8}$	$\frac{3}{8}$	$\frac{1}{2}$	$\frac{9}{16}$	$\frac{9}{16}$	$\frac{5}{8}$
$t = \frac{3}{8}$	$\frac{3}{8}$	$\frac{7}{16}$	$\frac{7}{16}$	$\frac{1}{2}$	$\frac{1}{2}$	$\frac{5}{8}$	$\frac{3}{4}$	$\frac{3}{4}$	$\frac{7}{8}$

107. **Round Taper Keys.** — For keying hand-wheels and other parts that are not subjected to very great stress, a cheap and satisfactory method is to use a round taper key driven into a hole drilled in the joint, as in Fig. 106. If the two parts are of different material, one much harder than the other, this method should not be used, as it is almost impossible in such case to make the drill follow the joint. For these keys it is customary to use Morse standard tapers, as reamers are then readily obtainable.

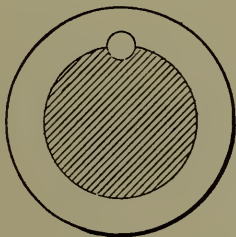

FIG. 106.

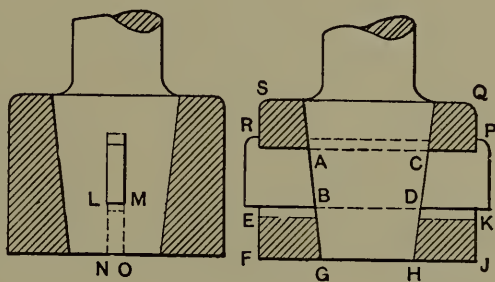

FIG. 107.

108. A **Cotter** is a key that is used to attach parts that are subjected to a force of tension or compression tending to separate them. Thus piston-rods are often connected to both piston and cross-head in this way. Also the sections of long pump-rods, etc.

Fig. 107 shows machine parts held against tension by cotters. It is seen that the joint may yield by shearing the cotter at *AB* and *CD*; or by shearing *CPQ* and *ARS*; by shearing on the surfaces *MO* and *LN*; or by tensile rupture of the rod on a horizontal section at *LM*. All of these sections should be sufficiently large to resist the maximum stress safely. The difficulty is usually to get *LM* strong enough in tension; but this may usually be accomplished by making the rod larger or the cotter thinner and wider. It is found that taper surfaces if they be smooth and somewhat oily will just cease to stick together when the taper equals 1.5 inches per foot. The

taper of the rod in Fig. 107 should be about this value in order that it may be removed conveniently when necessary

From consideration of the laws of friction it is obvious that where a taper cotter is used, either alone as in Fig. 108 or in connection with a gib as in Fig. 109, the angle of taper α must not exceed the friction angle ϕ . That is, if the coefficient of friction be μ , then $\mu = \tan \phi$ and $\tan \alpha$ must be less than $\tan \phi$ or μ . Since, for oily metallic surfaces, μ may have a value as low as 0.08, it follows that α must not exceed $4\frac{1}{2}^\circ$. If both surfaces of the cotter slope with reference to the line of action of the force, the total angle of the sloping sides must not exceed 9° .

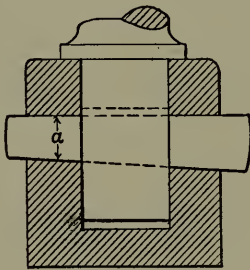

FIG. 108.

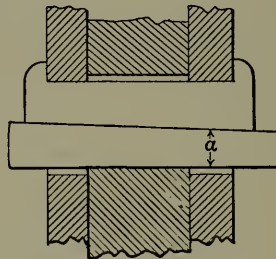

FIG. 109.

109. **Set-screws** (see § 86, p. 113) are frequently used to prevent relative rotation. They are inadvisable for heavy duty. Experiments made by Professor Lanza* with $\frac{5}{8}$ -inch wrought-iron set-screws, ten threads to the inch and tightened with a pull of 75 lbs. at the end of a 10-inch wrench, gave the following results:

TABLE XII.

Kind of End.	Holding Power at Surface of Shaft.
Ends perfectly flat, $\frac{9}{16}$ inch diameter. . .	Average 2064 lbs.
Rounded ends, radius $\frac{1}{2}$ inch diameter. .	“ 2912 “
Rounded ends, radius $\frac{1}{4}$ inch diameter. .	“ 2573 “
Cup-shaped and case hardened.	“ 2470 “

* Trans. A. S. M. E., Vol. X.

110. **Shrink and Force Fits.**—Relative rotation between machine parts is also prevented sometimes by means of shrink and force fits. In the former the shaft is made larger than the hole in the part to be held upon it, and the metal surrounding the hole is heated, usually to low redness, and because of the expansion it may be put on the shaft, and on cooling it shrinks and “grips” the shaft. A key is sometimes used in addition to this. For proper allowances see the accompanying table. The coefficient of linear expansion for each degree Fahrenheit is 0.0000065 for wrought iron and steel and 0.0000062 for cast iron. Low redness corresponds to about 600° F. and therefore causes an expansion of the bore of about 0.004 inch per inch of diameter.

Force fits are made in the same way except that they are put together cold, either by driving together with a heavy sledge or by forcing together by hydraulic pressure. The necessary allowance, *i.e.*, excess of shaft diameter over the diameter of the hole, is given in the following table (XIII), compiled by Mr. S. H. Moore.*

Column 1 gives values of “pressure factors” which are to be used in connection with forced fits to determine the pressure necessary to force the machinery steel shaft into the cast-iron hub. The formula to be used is

$$\text{Pressure in tons} = \frac{\text{Area of surface of fit} \times \text{difference in dia. between plug and bore} \times PF}{2}$$

In using this table for forced fits the surfaces should be as smooth as possible; if they are ground it is best. They should be well lubricated. Mr. Moore recommends linseed-oil for this purpose.

Compared with *average* practice the forcing-fit allowances of

* Trans. A. S. M. E., Vol. XXIV.

TABLE XIII.—DATA RELATIVE TO FITS AND FITTING.

Pressure Factors, <i>PF.</i>	Nominal Diameter of Fit.	Forcing Fit, Allowances.	Shrinking Fit, Allowances.	Driving Fit, Allowances.	Running Fit, Allowances.
	$\frac{1}{4}$0006	.00058
	$\frac{1}{2}$0008	.00065
	$\frac{3}{4}$0009	.00073
391	1	.0025	.0016	.0010	.0008
319	$1\frac{1}{2}$.0035	.0021	.0013	.0010
240	2	.0045	.0026	.0015	.0011
156	3	.0065	.0037	.0020	.0014
115	4	.0085	.0048	.0025	.0018
91	5	.0105	.0058	.0030	.0021
75	6	.0125	.0069	.0035	.0024
64	7	.0145	.0079	.0040	.0027
55	8	.0165	.0090	.0045	.0030
48.5	9	.0185	.0101	.0050	.0033
43	10	.0205	.0111	.0055	.0036
39	11	.0225	.0122	.0060	.0039
36	12	.0245	.0133	.0065	.0043
30.4	14	.0285	.0154	.0075	.0049
26.4	16	.0325	.0175	.0085	.0055
23.3	18	.0365	.0196	.0095	.0061
20.8	20	.0405	.02180068
18.8	22	.0445	.02390074
17.2	24	.0485	.02600080
15.1	27	.0545	.02920090
13.5	30	.0605	.03240099
	38		.040		
	44	$A = \frac{2D + .5}{1000}$.047	$A = \frac{3D + .5}{1000}$	$A = \frac{5D + .5}{1000}$
	50		.053		
	56		.060		
	62		.066		
	66		.070		

this table are too large. Satisfactory results will be obtained by using just one half these tabular values.

In general, pressure fits are not employed on diameters exceeding 10 ins., shrinkage fits being used for large work.

The alignment should be absolutely accurate in starting. To secure this some engineers resort to the use of two diameters—each half the length of the fit—differing by but a few thousandths of an inch.

Experience shows that, for same allowances, shrink fits hold more firmly than pressure fits.

III. Stress in Hub.—In regard to the tension in the hub due

to shrinkage or forced fits, completely satisfactory data are lacking. A close approximation to the probable tension in the inner layer of hub—the one next the shaft—may be made by considering the hub as a thick cylinder under internal pressure. Then*

$$f_1 = \frac{p_i(r_1^2 + r_2^2)}{r_2^2 - r_1^2}.$$

f_1 = unit stress in pounds per square inch in inner layer;

p_i = internal pressure in pounds per square inch;

r_1 = internal radius of hub in inches;

r_2 = external radius of hub in inches.

To determine the probable value of p_i we may proceed as follows: Knowing the maximum pressure in tons,

$$= \left(\frac{\text{area of surface of fit} \times A \times PF}{2} \right),$$

this may be presumed to be the resistance offered by friction between the surfaces. Assuming the coefficient of friction = 0.10, the total pressure between the surfaces is ten times as great as the forcing pressure. Reducing this total pressure to pounds, and dividing by the area of surface of fit, gives the pressure per square inch, or the value of p_i .

$$\therefore p_i = 10,000A \times PF.$$

112. Problem.—A hub $7\frac{1}{2}$ inches in diameter and 8 inches long is to be forced on a 5-inch shaft. What allowance should be made in difference of diameter of bore and shaft? What will be the necessary forcing pressure? What will be the tensile stress in the inner fibers of the hub?

* Ewing's "Strength of Materials," p. 210.

From the table the forcing-fit allowance for a 5-inch nominal diameter is $0.0105'' = A$.

The forcing pressure in tons

$$= \frac{(5 \times \pi \times 8) \times (0.0105) \times 91}{2} = 59.13,$$

since the table gives us $PF = 91$ for this case.

The internal pressure

$$p_i = 10,000 \times 0.0105 \times 91 = 9555 \text{ lbs. per square inch,}$$

and

$$f_1 = \frac{9555(2.5^2 + 3.75^2)}{3.75^2 - 2.5^2} = 24,811 \text{ lbs. per square inch.}$$

This is a dangerous value for cast iron and points to a greater outside diameter of hub or a smaller fit allowance. The rough rule of practice is to make the outside diameter of hub equal twice the diameter of the shaft for cast-iron hubs. This would reduce f_1 to 17,500 lbs., about. Or, using the original hub but only one half the tabular allowance, f_1 becomes 12,405 lbs.

CHAPTER X.

SLIDING SURFACES.

113. **General Discussion.**—So much of the accuracy of motion of machines depends on the sliding surfaces that their design deserves the most careful attention. The perfection of the cross-sectional outline of the cylindrical or conical forms produced in the lathe depends on the perfection of form of the spindle. But the perfection of the outlines of a section through the axis depends on the accuracy of the sliding surfaces. All of the surfaces produced by planers, and most of those produced by milling-machines, are dependent for accuracy on the sliding surfaces in the machine.

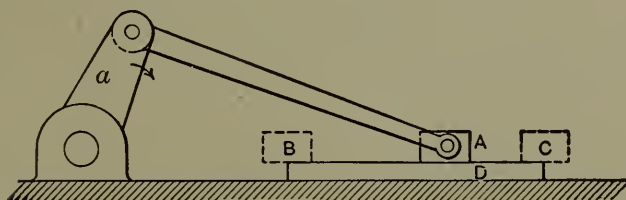

FIG. 110.

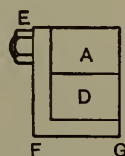

FIG. 111.

114. **Proportions Dictated by Conditions of Wear.**—Suppose that the short block A , Fig. 110, is the slider of a slider-crank chain, and that it slides on a relatively long guide D . The direction of rotation of the crank a is as indicated by the arrow. B and C are the extreme positions of the slider. The pressure between the slider and the guide is greatest at the mid-position, A ; and at the extreme positions, B and C , it is only the pressure due to the weight of the slider. Also the velocity is a maximum

when the slider is in its mid-position, and decreases towards the ends, becoming zero when the crank a is on its center. The work of friction is therefore greatest at the middle, and is very small near the ends. Therefore the wear would be the greatest at the middle, and the guide would wear concave. If now the accuracy of a machine's working depends on the perfection of A 's rectilinear motion, that accuracy will be destroyed as the guide D wears. Suppose a gib, EFG , to be attached to A , Fig. 111, and to engage with D , as shown, to prevent vertical looseness between A and D . If this gib be taken up to compensate for wear after it has occurred, it will be loose in the middle position when it is tight at the ends, because of the unequal wear. Suppose that A and D are made of equal length, as in Fig. 112. Then when A is in the mid-position corresponding

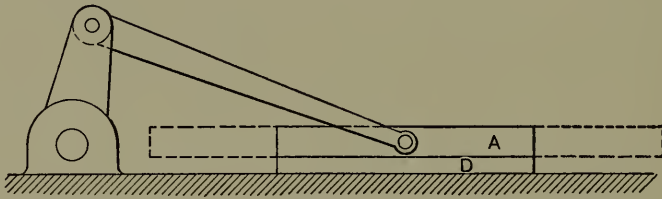

FIG. 112.

to maximum pressure, velocity, and wear, it is in contact with D throughout its entire surface, and the wear is therefore the same in all parts of the surface. The slider retains its accuracy of rectilinear motion regardless of the amount of wear; the gib may be set up, and will be equally tight in all positions.

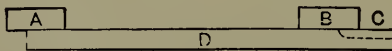

FIG. 113.

If A and B , Fig. 113, are the extreme positions of a slider, D being the guide, a shoulder would be finally worn at C . It would be better to cut away the material of the guide, as shown

by the dotted line. Slides should always "wipe over" the ends of the guide when it is possible. Sometimes it is necessary to vary the length of stroke of a slider, and also to change its position relatively to the guide. Examples: "Cutter-bars" of slotting- and shaping-machines. In some of these positions there will be a tendency, therefore, to wear shoulders in the guide and also in the cutter-bar itself. This difficulty is overcome if the slide and guide are made of equal length, and the design is such that when it is necessary to change the position of the cutter-bar that is attached to the slide, the position of the guide may be also changed so that the relative position of slide and guide remains the same. The slider surface will then just completely cover the surface of the guide in the mid-position, and the slider will wipe over each end of the guide whatever the length of the stroke.

In many cases it is impossible to make the slider and guide of equal length. Thus a lathe-carriage cannot be as long as the bed, a planer-table cannot be as long as the planer-bed, nor a planer-saddle as long as the cross-head. When these conditions exist especial care should be given to the following:

I. The bearing surface should be made so large in proportion to the pressure to be sustained that the maintenance of lubrication shall be insured under all conditions.

II. The parts which carry the wearing surfaces should be made so rigid that there shall be no possibility of the localization of pressure from yielding.

115. Form of Guides.—As to form, guides may be divided into two classes: angular guides and flat guides. Fig. 114, *a*, shows an angular guide, the pressure being applied as shown. The advantage of this form is, that as the rubbing surfaces wear, the slide follows down and takes up both the vertical and lateral wear. The objection to this form is that the pressure is not applied at right angles to the wearing surfaces, as

it is in the flat guide shown in *b*. But in *b*, a gib must be provided to take up the lateral wear. The gib is either a wedge

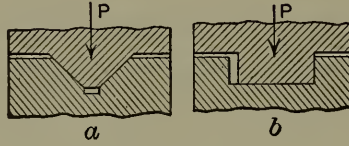

FIG. 114.

or a strip with parallel sides backed up by screws. Guides of these forms are used for planer-tables. The weight of the table itself holds the surfaces in contact, and if the table is light the tendency of a heavy side cut would be to force the table up one of the angular surfaces away from the other. If the table is very heavy, however, there is little danger of this, and hence the angular guides of large planers are much flatter than those of smaller ones. In some cases one of the guides of a planer-table is angular and the other is flat. The side bearings of the flat guide may then be omitted, as the lateral wear is taken up by the angular guide. This arrangement is undoubtedly good if both guides wear down equally fast.



FIG. 115.

Fig. 115 shows three forms of sliding surfaces such as are used for the cross-slide of lathes, the vertical slide of shapers, the table slide of milling-machines, etc. *A* is a taper gib that is forced in by a screw at *D* to take up wear. When it is necessary to take up wear at *B*, the screw may be loosened and a shim or liner may be inserted between the surfaces at *a*. *C* is a thin gib and the wear is taken up by means of several screws

like the one shown. This form is not so satisfactory as the wedge gib, as the bearing is chiefly under the points of the screws, the gib being thin and yielding, whereas in the wedge there is complete contact between the metallic surfaces.

The sliding surfaces thus far considered have to be designed so that there will be no lost motion while they are moving, because they are required to move while the machine is in operation. The gibs have to be carefully designed and accurately set so that the moving part shall be just "tight and loose"; *i.e.*, so that it shall be free to move, without lost motion to interfere with the accurate action of the machine. There is, however, another class of sliding parts, like the sliding-head of a drill-press, or the tailstock of a lathe, that are never required to move while the machine is in operation. It is only required that they shall be capable of being fastened accurately in a required position, their movement being simply to readjust them to other conditions of work while the machine is at rest. No gib is necessary and no accuracy of MOTION is required. It is simply necessary to insure that their position is accurate when they are clamped for the special work to be done.

116. Lubrication.—The question of strength rarely enters into the determination of the dimensions of sliding surfaces; these are determined rather by considerations of minimizing wear and maintaining lubrication. As long as a film of oil separates the surfaces, wear is reduced to a minimum. The allowable pressure between the surfaces without destruction of the film of lubricant varies with several conditions. To make this clear, suppose a drop of oil to be put into the middle of an accurately finished surface plate (*i.e.*, as close an approximation to a plane surface as can be produced); suppose another exactly similar plate to be placed upon it for an instant; the oil-drop will be spread out because of the force due to the weight

of the upper plate. Had the plate been heavier it would have been spread out more. If the plate were allowed to remain a longer time, the oil would be still further spread out, and if its weight and the time were sufficient, the oil would finally be squeezed entirely out from between the plates, and the metal surfaces would come into contact. The squeezing out of the oil is, therefore, a function of the *time* as well as of *pressure*.

If the surfaces under pressure move over each other, the removal of the oil is facilitated. The greater the velocity of movement the more rapidly will the oil be removed, and therefore the squeezing out of the oil is also a function of the *velocity of the rubbing surfaces*.

117. Allowable Bearing Pressure.—Flat surfaces in machines are particularly difficult to make perfectly true in the first place, and to keep true in the course of operation of the machines. If they are distorted ever so slightly the pressure between the surfaces becomes concentrated at one small area, and the actual pressure per square inch is vastly in excess of the nominal pressure.

In consequence of this and the differences in original truth and finish of the surfaces, there is no matter in machine design in which practice varies more than in the nominal pressure allowed per square inch of bearing area of flat sliding surfaces.

Unwin* gives the following:

TABLE XIV.

Slipper slide-blocks, marine engines.	100 lbs. per square inch
Stationary-engine slide-blocks.	25 to 125 " " "
Stationary-engine slide-blocks usually.	30 to 60 " " "

Professor Barr † found American practice to vary as follows:

* "Machine Design," 14th ed., Vol. I, p. 198.

† Trans. A. S. M. E., Vol. XVIII, p. 753.

Cross-head shoes of high-speed engines:

Minimum pressure per square inch.....	10.5 lbs.
Maximum pressure per square inch.....	38 “
Mean pressure per square inch.....	27 “

Cross-head shoes of low-speed engines:

Minimum pressure per square inch.....	29 lbs.
Maximum pressure per square inch.....	58 “
Mean pressure per square inch.....	40 “

In all cases the mean sliding velocity was probably in the neighborhood of 600 feet per minute with a maximum velocity at the middle of the stroke of about 950 feet per minute. In “low-speed” engines the maximum velocity is only reached about one third as many times per minute as in “high-speed” engines, although they may have the same mean velocity, and it is therefore proper to allow a higher unit value of pressure for the former than for the latter. For well-made surfaces the maximum values given by Professor Barr may be safely used.

For lower mean speeds than 600 feet per minute they may be increased, and for higher speeds decreased, according to some law such as

$$pV = 36,000,$$

in which formula p = pressure per square inch, and V = velocity of rubbing in feet per minute.

118. Maintenance of Lubrication.—Regarding the materials to be used, brass, bronze, or babbitt metal will run well with iron or steel.

To maintain lubrication a constant flow of oil from a cup is desirable. The moving surface should, if possible, have channels cut in its face to conduct the oil from the central oil-hole to all parts of the surface, as shown in Fig. 116. The oil should be forced in where the pressures are heavy.

Oil-pads may be used as shown in Fig. 117. The shaded

areas represent porous pads whose lower surfaces just touch the surface to be lubricated, and which are kept soaked with oil.

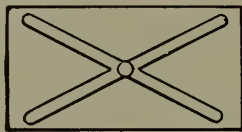

FIG. 116.



FIG. 117.

For oiling the ways of planer-tables it is customary to use rollers placed in oil-filled pockets in the guides. The top of

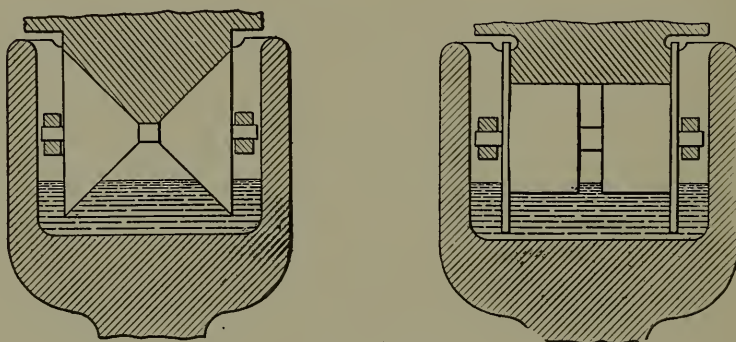

FIG. 118.

the roller is held against the surface of the way by means of springs. (See Fig. 118.)

CHAPTER XI.

AXLES, SHAFTS, AND SPINDLES.

119. By **Axles, Shafts, or Spindles** we denote those rotating or oscillating members of machines whose motion is constrained by turning pairs. Axle is the name given to such a member when it is subjected to a load which produces a bending moment, and the only torsional stress is that due to friction.

When rotating members are subjected chiefly to torsional stress, or combined torsion and bending, they are called shafts or spindles. The former term is used where the part has as its function the transmission of energy of rotation from one point to another. Examples are line-shafts and crank-shafts.

The term spindle, on the other hand, is restricted to those rotating members which are directly connected with the tool or work and give it an accurate rotative motion. They generally form the main axis of the machine. Examples are the lathe and drill-spindles.

120. **Axle Design.**—The question of axle design will be taken

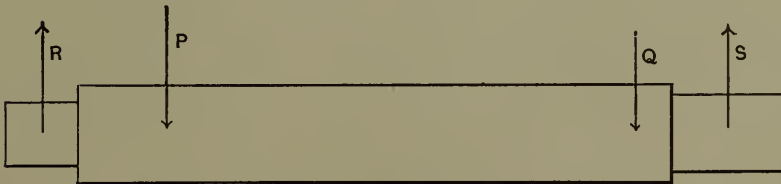

FIG. 119.

up first, and the torsional moment due to friction will be neglected.

A typical case is shown in Fig. 119. Here the two ends are

purposely not symmetrical. Given the loads P and Q , solution is first made for the reactions R and S by the ordinary methods of mechanics, graphical or analytical.

The graphical method is best since it gives the moments at all sections. Lay off the line $M-N$, Fig. 120, whose length equals $l' + l + l''$, the distance between the points of application of R and S . Denote the points of application of R , P , Q , and S by a , b , c , and d , respectively. At b erect a perpendicular and

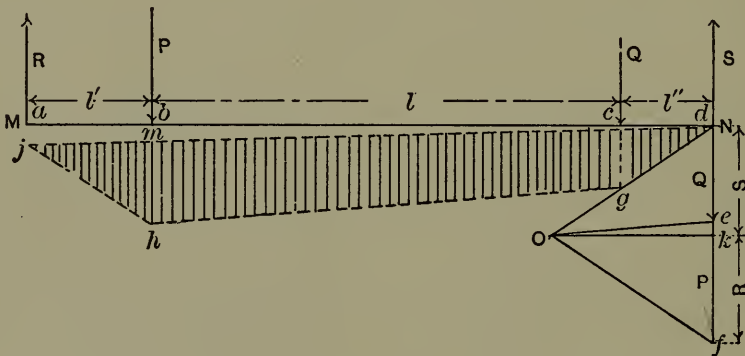

FIG. 120.

lay off on it a vector representing the value of P in pounds. At c erect a perpendicular and lay off on it a vector representing Q on the same scale. At d drop a perpendicular and lay off de equal to vector Q , and ej equal to vector P . Select any point O as pole, and draw Od , Oe , and Oj . Denote by g the point where Od intersects a perpendicular dropped from c , and draw from g a parallel to Oe until it intersects a perpendicular dropped from b at h . From h draw a parallel to Oj until it intersects a perpendicular dropped from a at j . Draw jd , and parallel to jd draw a line through O . This line cuts the perpendicular dropped from d at the point k . Then vector $jk = R$, and $kd = S$, on the same scale as was originally used for P and Q . Values of R and S in pounds are therefore determined. The shaded area $dghjd$ is the moment diagram. The vertical ordinates

included between its bounding lines are proportional to the moments at the corresponding points.

The scale of the moment diagram can be readily determined by solving for the actual moment for one section. Select the section at b . The moment M_b is represented by mh and has a value $=Rl'$, R being expressed in pounds and l' in inches; the value of the moment in inch-pounds can be determined at any point, since the scale used is mh inches equals Rl' inch-pounds.

For a circular section we have the elastic moment

$$M_b = \frac{f_t I}{c} = \frac{f_t \pi r^3}{4}.$$

M_b is the bending moment in inch-pounds;

f_t is the unit stress in outer fiber in pounds per square inch;

I is the plane moment of inertia of the section in biquadratic inches;

c is the distance from neutral axis to outermost fiber in inches.

Equating this to the various selected values of M_b and solving for r gives the radius of the axle at any point.

In designing axles, great care must be taken that all forces acting are being considered, and that the maximum value of each is selected.*

Thus it has been found that the force due to vertical oscillation caused by jar in running is about 40 per cent of the static load for car-axles. The axles would therefore have to be designed for a load 1.4 times the static load. In addition to this there is in car-axles a bending moment due to curves, switches, and wind-pressures. This may amount as a maximum to the equivalent of a horizontal force H , equal to 40 per cent of the static load, applied at a height of 6 feet from the rail.

* See further Proc. Master Car-Builders' Assn., 1896; Report of Committee on Axles, etc. Also Strength of Railway-Car Axles, Trans. A. S. M. E., 1895. Reuleaux, "The Constructor," trans. by H. H. Supplee, Philadelphia, 1893.

When such a careful analysis of the forces has been made, f_t may be taken for good material, equal to one fourth of the ultimate strength, this being a safe value for cases like this, where the fibers are subjected to alternate tension and compression as determined by Wöhler and others.

Had the static load alone been considered in the calculations, f_t should not have been taken greater than one tenth of the ultimate strength.

121. Shafting Subject to Simple Torsion.—If a short shaft is subjected to simple torsion, its diameter may be determined very readily by the simple formula for torsional moment,

$$M_t = PR = \frac{f_s J}{c}.$$

Here $M_t = PR$ is the torsional moment, P being the force tending to twist the piece in pounds and R being the lever-arm of P about the axis of the piece in inches.

J is the polar moment of inertia of the cross-section of the member in biquadratic inches;

c is the distance from the neutral axis to the outermost fiber in inches;

f_s is the allowable unit stress in pounds per square inch.

For a solid circular section

$$\frac{J}{c} = \frac{\pi r^3}{2}$$

and

$$M_t = \frac{f_s \pi r^3}{2},$$

which can be solved readily for r , the radius of the shaft.

For a hollow circular (*i.e.*, ring-shaped) section,

$$\frac{J}{C} = \frac{\pi(r_1^4 - r_2^4)}{2r_1}$$

and

$$M_t = \frac{f_s \pi(r_1^4 - r_2^4)}{2r_1}.$$

Here r_1 is the radius of the outside of the shaft and r_2 is the radius of the bore, both in inches.

The way to solve this is to take r_2 as a decimal part of r_1 . Thus, let $r_2 = br_1$. It then becomes an easy matter to solve for r_1 .

122. **Shafting Subject to Combined Torsion and Bending.**— In most cases shafts are subjected to combined torsion and bending. Consider the crank-shaft shown in Fig. 121 in side and end view.

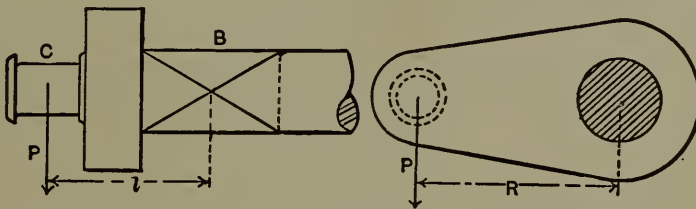

FIG. 121.

B is the center of the bearing, C is the center of the crank-pin. At B we have the shaft subjected to a bending moment, $M_b = Pl$, and also to a twisting moment, $M_t = PR$.

Let M_{eb} represent the bending moment which would produce the same stress in the outer fiber as M_b and M_t combined. It will be called the equivalent bending moment. Then it has been found* that

$$M_{eb} = 0.35M_b + 0.65\sqrt{M_b^2 + M_t^2}. \quad \dots \quad (1)$$

* This corresponds to most recent investigations. See Bach, "Elasticität und Festigkeit." For simplicity's sake Bach's coefficient α_0 has been dropped, as it modifies the result very slightly for wrought iron and steel.

Also,
$$M_{eb} = \frac{fI}{c} \dots \dots \dots (2)$$

For a circular section (2) becomes

$$M_{eb} = \frac{f\pi r^3}{4}$$

and substitution in (1) gives

$$\frac{f\pi r^3}{4} = 0.35M_b + 0.65\sqrt{M_b^2 + M_t^2}, \dots \dots (3)$$

which can readily be solved for r , f being given a value equal to the maximum allowable unit tensile stress for the material and conditions.

For a hollow circular section

$$\frac{f\pi(r_1^4 - r_2^4)}{4r_1} = 0.35M_b + 0.65\sqrt{M_b^2 + M_t^2} \dots \dots (4)$$

To solve this express r_2 as a decimal part of r_1 . Substitute and solve for r_1 .

If there are several forces acting, as there are apt to be, the method is as follows: First, find M_b due to all the bending forces combined. Second, find M_t due to all the twisting forces combined. Third, use these values of M_b and M_t in equations (1), (3), and (4). Among the forces acting we must not fail to include the weight of the shaft and attached parts.

123. Comparison of Solid and Hollow Shafts.—It is evident from (3) and (4) that the dimensions of a solid shaft and a hollow shaft of equal strength will have the relationship

$$r = \sqrt[3]{\frac{r_1^4 - r_2^4}{r_1}}$$

If $r_2 = 0.6r_1$, we have

$$r = \sqrt[3]{0.87r_1^3},$$

$$r = 0.955r_1.$$

Hence a hollow shaft whose internal bore is 0.6 of its external diameter, in order to have the same strength as a solid shaft must have its external diameter 1.047 times the diameter of the solid shaft. The weight of the hollow shaft will be 70 per cent of that of the solid shaft. It is obvious that a considerable saving in weight may be effected without appreciable increase in size if the hollow section is adopted. By using nickel steel in connection with the hollow section we can get combined maximum strength and lightness.*

124. Angular Distortion.—The angle by which a shaft subjected to torsion is twisted is often an important matter. Let this angle be represented by ϑ . Then

$$\vartheta = \frac{M_t L 180}{JG\pi} \dots \dots \dots (5)$$

ϑ = angle of torsion in degrees;

M_t = twisting moment in inch-pounds;

L = length of shaft in inches;

J = polar moment of inertia in biquadratic inches;

G = modulus of torsion = $\frac{\text{modulus of elasticity}}{2.6}$.

125. Combined Thrust and Torsion.—When a shaft is subjected to combined thrust and torsion, the following formula has been developed by Prof. A. G. Greenhill: †

* See "Nickel Steel," a paper by D. H. Browne in Vol. 29 of the Trans. A. I. M. E.

† See Proc. of Inst. of M. E., 1883, p. 182.

$$\frac{\pi^2}{l^2} = \frac{P}{EI} + \frac{M_t^2}{4E^2I^2}.$$

l = the length of shaft between bearings in inches;

P = the end thrust in pounds;

E = modulus of elasticity;

I = plane moment of inertia of the section in biquadratic inches;

M_t = twisting moment in inch-pounds.

This formula is strictly only applicable to vertical shafts, as it ignores the important item of bending due to the weight of the shaft and attached parts.

126. Line-shafts.—Line-shafts are long shafts used to transmit power. They are made of lengths coupled together and supported by bearings at suitable intervals. Pulleys or gears are keyed to them, and should always be placed as close to the supporting bearings as possible.

Consider first a length of such a shaft which is subjected to pure torsion only, no pulleys being mounted on it.

Because of its weight, the length of shaft between a pair of bearings will sag so that its axis will not be a straight line.

When a shaft revolves at a high speed, its own inertia gives it a tendency to instability independent of the torsion to which the shaft is subjected. This is due to the action of centrifugal force.

The "sag" of the shaft causes the center of mass to lie off the axis of rotation. At a certain speed the centrifugal force is just sufficient to keep the shaft bent. As this critical speed is passed the rapidly increasing centrifugal force exceeds the elastic forces of the material and the bending becomes large. The shaft is then said to "whirl."

The relation existing between the speed, size of shaft, and

distance between bearings which gives rise to whirling in wrought iron or steel shafts is as follows:

$$L = 400\sqrt{\frac{r}{n}}.$$

This applies to an unloaded shaft with bearings which do not fix the direction of the ends.

L = distance between bearings in inches;

r = radius of shaft in inches;

n = revolutions of shaft per second.

This becomes a matter of importance in rapidly rotating shafts.

When there are pulleys on the shaft the value of L naturally becomes smaller.*

If line-shafts are designed wholly for strength, *i.e.*, if d is determined by means of equation (3), owing to their length, there is apt to be an excessive angular distortion ϑ . It is therefore customary to design them for stiffness and check for strength afterwards.

ϑ should not exceed 0.075° per foot of shaft.

Combining this rule with the formula (5) for angular distortion,

$$\vartheta = \frac{M_t L 180}{JG\pi};$$

for a round wrought-iron or steel solid shaft we get

$$d = 4.8\sqrt[4]{\frac{\text{H.P.}}{N}},$$

when d = diameter of shaft in inches;
 H.P. = horse-power to be transmitted;
 N = revolutions per minute of shaft.

* For a very complete discussion of " Whirling and Vibration of Shafting," see an article by Professor Dunkerly in the Phil. Trans. of the Roy. Soc. of London, Vol. 185A, Part I, p. 279.

Having determined the diameter which will give sufficient stiffness against torsion the allowable distance between supporting bearings must be calculated. The rule of practice is to limit the deflection to 1/100 of an inch to a foot of length.

Consider first a bare shaft. There are three cases:

- 1st. Both ends of the shaft are free to take any direction.
- 2d. One end is free and one fixed.
- 3d. Both ends are fixed.

In each case

L = length of span in inches;

w = weight of shaft per inch;

y = maximum deflection;

$\frac{24y}{L}$ = average deflection per foot of length

= 1/100 inch;

$$\therefore y = \frac{L}{2400}.$$

Each case is that of a uniformly loaded beam with a load = wL .

For case I, the deflection $y = \frac{wL^4}{77EI}$.

For case II, the deflection $y = \frac{wL^4}{192EI}$.

For case III, the deflection $y = \frac{wL^4}{384EI}$.

Since $y = \frac{L}{2400}$, and for round shafting $I = \frac{\pi d^4}{64}$ and $w = .28 \frac{\pi d^2}{4}$, while $E = 30,000,000$, it follows that

$$\text{(Case I)} \quad L = 75 \sqrt[3]{d^2};$$

$$\text{(Case II)} \quad L = 100 \sqrt[3]{d^2};$$

$$\text{(Case III)} \quad L = 130 \sqrt[3]{d^2}.$$

When there are loads due to belt pull, etc., the deflection must be determined in each case. For ordinary purposes, with the average number of pulleys and amount of belt pull, it is safe to take for loaded shafts $\frac{6}{10}$ of the value of L determined for bare shafting for the same conditions.

CHAPTER XII.

JOURNALS, BEARINGS, AND LUBRICATION.

127. **General Discussion of Journals and Bearings.**—Journals and the bearings or boxes with which they engage are the elements used to constrain motion of rotation or vibration about axes in machines. Journals are usually cylindrical, but may be conical, or, in rare cases, spherical. The design of journals, as far as size is concerned, is dictated by one or more of the four following considerations:

(1) To provide for safety against rupture or excessive yielding under the applied forces.

(2) To provide for maintenance of form.

(3) To provide against the squeezing out of the lubricant.

(4) To provide against overheating.

To illustrate (1), let Fig. 122 represent a pulley on the end of an overhanging shaft driven by a belt, *ABC*. Rotation is as indicated by the arrow, and the belt tensions are T_1 and T_2 . The journal, *J*, engages with a box or bearing, *D*. The following stresses are induced in the journal: **TORSION**, measured by the torsional moment $(T_1 - T_2)r$. **FLEXURE**, measured by the bending moment $(T_1 + T_2)a$. This assumes a rigid shaft or a self-adjusting box. **SHEAR**, resulting from the force $T_1 + T_2$. This journal must therefore be so designed that rupture or undue yielding shall not result from these stresses.

To illustrate (2), consider the spindle journals of a grinding-lathe. The forces applied are very small, but the **FORM**

of the journals must be maintained to insure accuracy in the product of the machine. A relatively large wearing surface

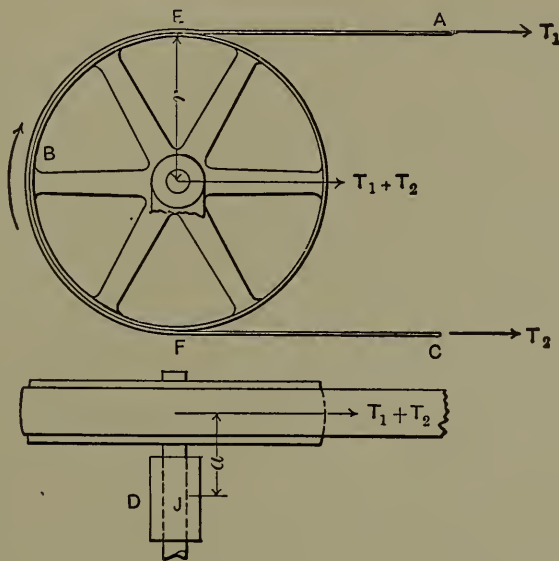

FIG. 122.

is therefore necessary, and careful provision must be made to exclude dust and grit.

To illustrate (3), the pressure upon a journal resulting from the applied forces may be sufficiently great to squeeze out the lubricant. Metallic contact, heating, and abrasion of the surfaces would result. In what follows, the area of a journal means its PROJECTED area; *i.e.*, its length multiplied by its diameter.

128. Allowable Bearing Pressure.—The allowable pressure per square inch of area of a journal varies with several conditions. The illustration of the drop of oil between two surface plates, given in the discussion of sliding surfaces (p. 157), applies here also. The squeezing out of the oil from between the rubbing surfaces of a journal and its box is, therefore, a function of the TIME as well as of pressure. If the surfaces under pressure move over each other, the removal of the oil is facilitated. The greater the velocity of movement,

the more rapidly will the oil be removed, and therefore the squeezing out of the oil is also a function of the VELOCITY OF RUBBING SURFACES.

When a journal is subjected to continuous pressure in one direction, as, for instance, in a shaft with a constant belt pull, or with a heavy fly-wheel upon it, this pressure has sufficient time to act, and is therefore effective for the removal of oil. But if the direction of the pressure is periodically reversed, as in the crank-pin of a steam-engine, the time of action is less, the tendency to remove the oil is reduced, and the oil has opportunity to return between the surfaces. Hence a higher pressure per square inch of journal would be allowable in the second case than in the first.

If the direction of motion is also reversed, as in the cross-head pin of a steam-engine, the oil has not only an opportunity to return between the surfaces, but is assisted in doing so by the reversed motion. Therefore a still higher pressure per square inch of journal is allowable. Practical experience bears out these conclusions.

The allowable pressure depends also upon the workmanship as shown in the fit of journal and box and the condition of the bearing surfaces. The value to be used in each case must be decided by the judgment of the designer. The following table based upon practice may be taken as a guide:

TABLE XV.—ALLOWABLE JOURNAL PRESSURES.

Kind of Bearing.	Pressure in Lbs. per Sq. In. of Projected Area.
Bearings for slow speed and intermittent load, such as crank-pins of shearing-machines.	2000-3000
Main journals, center-crank high-speed engines.	180- 240
Main journals, side-crank low-speed engines.	160- 220
Crank-pins of high-speed engines.	250- 600
Crank-pins of low-speed engines.	870-1550
Cross-head pins of high-speed engines.	910-1675
Cross-head pins of low-speed engines.	1000-1860
Car-axle journals.	300- 600

129. **Heating of Journals.**—To illustrate (4), even if the conditions are such that the lubricant is retained between the rubbing surfaces, heating may occur. There is always a frictional resistance at the surface of the journal; this resistance may be reduced (*a*) by insuring accuracy of form and perfection of surface in the journal and its bearings; (*b*) by insuring that the journal and its bearings are in contact, except for the film of oil, throughout their entire surface, by means of rigidity of framing or self-adjusting boxes, as the case may demand; (*c*) by selecting a suitable lubricant to meet the conditions and maintaining the supply to the bearing surfaces. By these means the friction may be reduced to a very low value, but it cannot be reduced to zero.

There must be some frictional resistance, and it is always converting mechanical energy into heat. This heat raises the temperature of the journal and its bearing. If the heat thus generated is conducted and radiated away as fast as it is generated, the box remains at a constant low temperature. If, however, the heat is generated faster than it can be disposed of, the temperature of the box rises till its capacity to radiate heat is increased by the increased difference of temperature of the box and the surrounding air, so that it is able to dispose of the heat as fast as it is generated. This temperature, necessary to establish the equilibrium of heat generation and disposal, may under certain conditions be high enough to destroy the lubricant or even to melt out a babbitt-metal box-lining. Suppose now that a journal is running under certain conditions of pressure and surface velocity, and that it remains entirely cool. Suppose next that, while all other conditions are kept exactly the same, the velocity is increased. All modern experiments on the friction in journals show that the coefficient of friction increases with the increase of velocity of rubbing surface (at speeds above 100 feet per minute). Therefore the in-

crease in velocity would increase the frictional resistance at the surface of the journal, and the space through which this resistance acts would be greater in proportion to the increase in velocity. The work of the friction at the surface of the journal is therefore increased because both the force and the space factors are increased. It is this work of friction which has been so increased, that produces the heat which tends to raise the temperature of the journal and its box. The rate of generation of heat has therefore been increased by the increase in velocity, but the box has not been changed in any way, and therefore its capacity for disposing of heat is the same as it was before, and hence the tendency of the journal and its bearing to heat is greater than it was before the increase in velocity. Some change in the proportions of the journal must be made in order to keep the tendency to heat the same as it was before the increase in velocity. If the diameter of the journal be increased, the radiating surface of the box will be proportionately increased. But the space factor of the friction will be increased in the same proportion, and therefore it will be apparent that this change has not affected the relation of the rate of generation of heat to the disposal of it. But if the length of the journal be increased, the work of friction is the same as before and the radiating surface of the box is increased and the tendency of the box to heat is reduced. If, therefore, the conditions are such that the tendency to heat in a journal, because of the work of the friction at its surface, is the vital point in design, it will be clear that the length of the journal is dictated by it, but not the diameter. The reason why high-speed journals have greater length in proportion to their diameter than low-speed journals will now be apparent.

The lost work per minute due to friction may be expressed by $P\mu\pi dN$, in which P =mean total pressure on journal, μ =coefficient of friction, d =diameter of journal, and N =revo-

lutions per minute. This energy is all converted into heat which should be dissipated through a surface which is proportional to the projected area of the journal, dl . It follows that, other conditions remaining constant, the projected area should be proportional to the heat generated, and we may write

$$\frac{P\mu\pi dN}{dl} = K.$$

$$\therefore l = \frac{P\mu\pi N}{K}.$$

K must be experimentally determined for a given set of conditions. Sufficient data are not available to form a general table of values of K .

130. **Journal Proportions.**—The proportions of engine-journals* may be seen in the following table:

TABLE XVI.

Kind of Journal.	Value of $\frac{l}{d}$.		
	Minimum.	Maximum.	Average.
Main journal, center-crank high-speed engine...	2.0	3.0	2.2
Main journal, side-crank low-speed engine.....	1.7	2.1	1.9
Crank-pin high-speed engine.....	1.0†
Crank-pin low-speed engine.....	1.1†
Cross-head pin high-speed engine.....	1.0	2.0	1.25
Cross-head pin low-speed engine.....	1.0	1.5	1.3

131. **Materials to be Used.**—Regarding the materials of journals and their boxes the following general statements may be made. It must be borne in mind that the terms babbit, brass, and bronze cover wide ranges of alloys of varying values.

Cast iron, wrought iron, soft steel, and hard steel will all run

* Professor Barr on "Current Practice in Engine Proportions," Trans. A. S. M. E., Vol. 18, p. 737.

† Unpublished data, same investigations.

well at almost any speed on babbitt metal. The pressure per square inch which an ordinary babbitt bearing will stand when running cool (*i.e.*, at very slow speed), before being squeezed out, has been found to be something over 2000 lbs.*

Cast iron, wrought iron, soft steel, and hard steel will all run well on brass and bronze. Brass and bronze of ordinary compositions will carry 5000 lbs. per square inch without suffering destruction. Bronze, however, is much better than brass.

Cast iron will run on cast iron where, owing to large bearing surfaces, the unit pressure is light. Where the pressure and speed are high, as in engine-journals, this will not work.†

In the same way steel will run on cast iron even at high speeds if the pressure is light. It has been found that steel will not run on cast iron in engine-journals.‡

Wrought iron, soft steel, and hard steel will all run on hard steel.

Steel under steel if hardened and polished will run under as high a pressure as 50,000 lbs. per square inch.

132. Calculation of Journals for Strength.—Journals generally form parts of axles on shafts, and the calculation of their diameter for strength becomes part of the calculation of the shaft. The principles have been developed at length in the preceding chapter and need not be repeated here.

If the journal is so held that it may be considered as subjected to pure shearing stress, like the crank-pin of a center-crank engine, then

$$f_s A = P,$$

in which P = total maximum load;

A = total area subjected to stress;

f_s = safe shearing stress for the conditions.

* C. F. Porter, Trans. A. S. M. E., Vol. III, p. 227.

† Trans. A. S. M. E., Vol. VI, pp. 853-854.

‡ *Ibid.*

For a journal subjected to a pure bending moment,

$$Pl = \frac{fI}{c},$$

which becomes $Pl = \frac{f\pi r^3}{4}$ for a solid circular shaft. Pl = bending moment, f = safe unit stress, and r = radius of shaft. This can readily be solved for r .

If the journal be hollow,

$$Pl = \frac{f\pi(r_1^4 - r_2^4)}{4r_1},$$

r_1 being the external and r_2 the internal diameter.

For combined bending and twisting such as the main journal of a side-crank engine is subjected to, the expression for a solid journal is

$$f \frac{\pi r^3}{4} = 0.35M_b + 0.65\sqrt{M_b^2 + M_t^2}.$$

For a hollow circular section

$$\frac{f\pi(r_1^4 - r_2^4)}{4r_1} = 0.35M_b + 0.65\sqrt{M_b^2 + M_t^2},$$

M_b being the bending moment and M_t the twisting moment.

In general it will be found that journals proportioned for strength merely will not have sufficient area to prevent heating, so this item must not be overlooked.

133. Problem.—Design the main journal of a side-crank low-speed engine.

Diameter of cylinder = 16 ins.

Length of stroke = 36 ins.

Net forward pressure = 100 lbs. per square inch of piston area.

Suppose the engine capable of carrying full pressure to half-stroke.

The area of piston = 201.06 square inches.

∴ total net forward pressure = 20,106 lbs.

At point of maximum torsional effect, which corresponds to the position of maximum velocity of piston, no energy is used in accelerating reciprocating parts, and

$$F_p v_p = F_c v_c;$$

F_p = net forward force on piston;

v_p = velocity of piston;

F_c = force on crank;

v_c = velocity of crank.

Since v_c is less than v_p for this position, F_c is greater than F_p , since $F_c = \frac{F_p v_p}{v_c}$.

Assuming a connecting-rod length equal to five and a half crank lengths gives (Appendix) $F_c = 20,500$ lbs.

Since the crank length is 18 inches, and at this position the crank and connecting-rod are nearly at a right angle with each other, there is a twisting moment at the journal equal to

$$M_t = 20,500 \times 18 = 369,000 \text{ inch-lbs.}$$

There is also a bending moment equal to $20,500 \times$ the distance from center of crank-pin to center of main journal. In

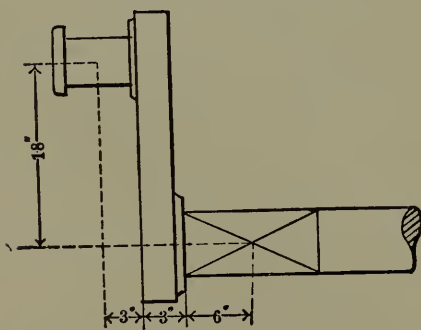

FIG. 123.

most cases this distance must be assumed; for, although the length of the crank-pin and the thickness of the crank may be known, the length of the main journal is unknown, since this length and the journal diameter are the very dimensions sought. Assume then that the crank-pin is 6 inches long, the crank 3 inches thick, and the middle of main journal 6

inches from the inner face of crank as shown in Fig. 123. This will give 12 inches as the lever-arm; \therefore the bending moment, $M_b = 20,500 \times 12 = 246,000$ inch-lbs.

The equivalent bending moment to the combined actual bending and twisting moments

$$\begin{aligned} &= M_{eb} \\ &= 0.35 \times 246,000 + 0.65 \sqrt{246,000^2 + 369,000^2} \\ &= 374,375 \text{ inch-lbs.} \end{aligned}$$

But

$$M_{eb} = \frac{f\pi r^3}{4};$$

$$\therefore r^3 = \frac{4 \times 374,375}{\pi f}.$$

For a main shaft like this f may be taken = 12,000 lbs. per square inch for steel.

$$\begin{aligned} \therefore r &= \sqrt[3]{\frac{4 \times 374,375}{\pi \times 12,000}} \\ &= 3.41 \text{ inches;} \end{aligned}$$

\therefore diameter of journal = $2 \times 3.41 = 6.82$, say 7 inches.

The length according to practice would be about twice this diameter,* or 14 inches. This would give a projected area of 98 square inches and a pressure of something over 200 lbs. per square inch of bearing due to steam-pressure alone.

To get the actual maximum pressure on the journal it would be necessary to know the weight of the shaft, flywheel, and other attached parts, and properly combine the pressure due to these with the pressure due to the steam.

The rough rule of practice for Corliss engines is to make the diameter of main journal equal to one half the diameter of the cylinder.

* See Table XVI, p. 177.

134. **Problem.**—Design the crank-pin for the same engine. It will be found that the crank-pin must be designed with reference to maintaining lubrication, and that it will have an excess of strength.

Allowing 1200 lbs. per square inch of area,* and noting from the table that the average practice for this type of engine is to make the length of the pin = 1.1 × the diameter, † it follows that

$$dl = \frac{20500}{1200},$$

but $l = 1.1d;$

$$\therefore 1.1d^2 = \frac{20500}{1200},$$

and $d = 4$ inches, nearly;

$$\therefore l = 1.1 \times 4 = 4\frac{1}{2} \text{ inches, say.}$$

Checking this for strength, considering the pin subjected to a bending moment $P\frac{l}{2}$, we write

$$P\frac{l}{2} = \frac{f\pi r^3}{4},$$

$$P = 20500 \text{ lbs.,}$$

$$\frac{l}{2} = \frac{4.5}{2} = 2.25 \text{ inches;}$$

$$r = 2 \text{ inches,}$$

$$f = \text{stress in outer fiber;}$$

$$\therefore f = \frac{4 \times 20500 \times 2.25}{\pi \times 8} = 7300 \text{ lbs. per square inch;}$$

which is, of course, a perfectly safe value for wrought iron or steel.

* See Table XV, p. 174.

† See Table XVI, p. 177.

135. Problem.—Design the cross-head pin for the same engine. This pin also should be designed for maintaining lubrication. Allowing 1400 lbs. per square inch as the permissible pressure on the journal,* and noting that the length may be taken as 1.3 times the diameter from average practice † gives

$$dl = \frac{20500}{1400},$$

$$l = 1.3d,$$

$$\therefore 1.3d^2 = \frac{20500}{1400},$$

and

$$d = 3\frac{3}{8} \text{ inches};$$

$$\therefore l = 4\frac{1}{2} \text{ inches.}$$

Checking this for strength it is evident that the only way

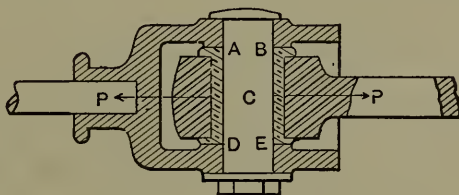

FIG. 124.

this pin can fail is by shearing on two surfaces, *A-B* and *D-E* (see Fig. 124).

$$P = f_s 2\pi r^2;$$

$$\therefore f_s = \frac{20500}{2 \times \pi \times 2.84} = 1150 \text{ lbs. per square inch.}$$

This leaves so great a margin of safety that some manufacturers make the cross-head pin of two parts, an inner pin of soft, resilient material, sufficiently large to resist the shearing stress, and an outer hard-steel bushing which surrounds the soft pin, but is not allowed to turn on it. The nature of

* See Table, XV, p. 174.

† See Table XVI, p. 177.

the forces acting on a cross-head pin tend to wear it to an oval cross-section. As such wear takes place the bushing can readily be given a quarter turn and clamped in the new position. (See Fig. 124.)

136. Maintenance of Form.—Journals whose maintenance of form is of chief importance must be designed from precedent, or according to the judgment of the designer. No theory can lead to correct proportions. In fact these proportions are eventually determined by the process of Machine Evolution.

137. Thrust-journals.—When a rotating-machine part is subjected to pressure parallel to the axis of rotation, means must be provided for the safe resistance of that pressure. In the case of vertical shafts the pressure is due to the weight of the shaft and its attached parts, as the shafts of turbine water-wheels that rotate about vertical axes. In other cases the pressure is due to the working force, as the shafts of propeller-wheels, the spindles of a chucking-lathe, etc. The end-thrusts of vertical shafts are very often resisted by the “squared-up” end of the shaft. This is inserted in a bronze or brass “bush,” which embraces it to prevent lateral motion, as in Fig. 125. If the pressure be too great, the end of the shaft may be enlarged so as to increase the bearing surface, thereby reducing the pressure per square inch. This enlargement

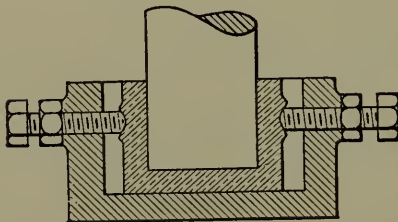

FIG. 125.

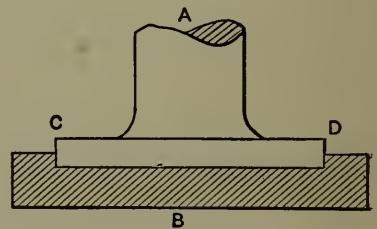

FIG. 126.

must be within narrow limits, however. (See Fig. 126.) *AB* is the axis of rotation, and *ACD* is the rotating part, its bear-

ing being enlarged at *CD*. Let the conditions of wear be considered. The velocity of rubbing surface varies from zero at the axis to a maximum at *C* and *D*. It has been seen that the increase of the velocity of rubbing surface increases both the force of the friction and the space through which that force acts; it therefore increases the work of the friction, and therefore the tendency to wear. From this it will be seen that the tendency to wear increases from the center to the circumference of this "radial bearing," and that, after the bearing has run for a while, the pressure will be localized near the center, and heating and abrasion may result. For this reason where there is severe stress to be resisted, the bearing is usually divided up into several parts, the result being what is known as a "collar thrust-bearing," as shown in Fig. 127.

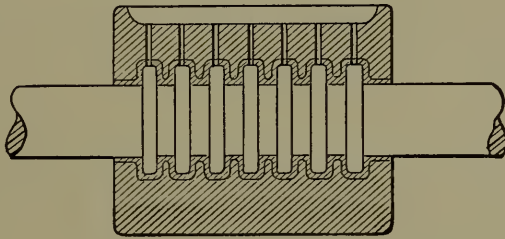

FIG. 127.

By the increase in the number of collars, the bearing surface may be increased without increasing the tendency to unequal wear. The radial dimension of the bearing is kept as small as is consistent with the other considerations of the design. It is found that the "tractrix," the curve of constant tangent, gives the same work of friction, and hence the same tendency to wear in the direction of the axis of rotation, for all parts of the wearing surface. (See "Church's Mechanics," page 181.)

This has been very incorrectly termed the "anti-friction" thrust-bearing. This is far from being the case. The friction work for this and all conical thrust-bearings can be shown

readily to be excessive. Their one advantage is that they are easily adjustable. In general they are to be avoided.

The pressure that is allowable per square inch of projected area of bearing surface varies in thrust-bearings with several conditions, as it does in journals subjected to pressure at right angles to the axis.* Thus, in the pivots of turntables, swing-bridges, cranes, and the like the movement is slow and never continuous, often being reversed; and also the conditions are such that "bath lubrication" may be used, and the allowable unit pressure is very high—equal often to 1500 lbs. per square inch, and in some cases greatly exceeding that value. The following table may be used as an approximate guide in the designing of thrust-bearings. The material of the thrust-journal is wrought iron or steel, and the bearing is of bronze or brass (babbitt metal is seldom used for this purpose). Bath lubrication is used, *i.e.*, the running surfaces are submerged constantly in a bath of oil.

TABLE XVII.

Mean Velocity of Rubbing Surface, Feet per Minute.	Allowable Unit Pressure, Pounds per Square Inch of Projected Area of the Rubbing Surface.
Slow and intermittent.	1500
50.	200
50 to 100.	100
100 to 150.	75
150 to 200.	60
Above 200.	50

If the journal is of cast iron and runs on bronze or brass, the values of allowable pressure given should be divided by two.

The most efficient forms of thrust-bearings are those † employing the principles shown in Fig. 128.

* See Proc. Inst. M. E., 1888 and 1891, for reports on experiments with thrust-bearings.

† See Trans. A. S. M. E., Vol. VI, p. 852, and Proc. Inst. M. E., 1888, p. 184.

Between the end of the shaft and the bottom of the step a series of accurately finished disks are introduced. The disks are alternately hard steel and bronze, the top one is fastened to the shaft, the lower to the step, and the rest are free. As indicated, each disk has a hole through the middle and radial grooves

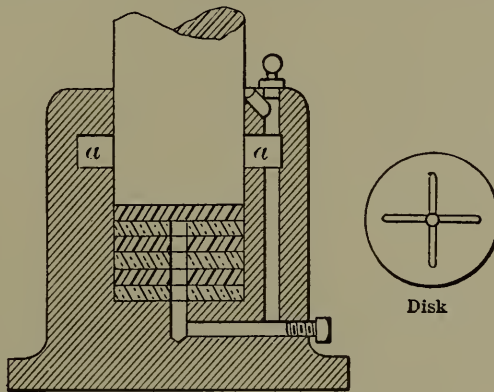

FIG. 128.

to permit the lubricant to have access between the disks. The effect of centrifugal force when the shaft is rotating is to force the oil outward from between the plates and upward. It is collected in the annular chamber *a-a* and flows from there down the drilled passages back to the bottom of the bearing. This is equivalent to a continuous automatic pump action supplying oil to the surfaces.

This form of bearing reduces the relative motion between successive surfaces to a minimum, thereby allowing much higher pressures to be carried.

A similar arrangement of loose disks can be used to great advantage on small propeller shafts and on worm shafts.

When bearings have to be used where corrosion or electrolytic action is to be feared, as in turbine work, glass and the end grain of very hard woods have been used successfully as bearing materials.

138. Problem.—It is required to design the collar thrust-journal that is to receive the propelling pressure from the screw

of a small yacht. The necessary data are as follows: The maximum power delivered to the shaft is 70 H.P.; pitch of screw is 4 feet; slip of screw is 20 per cent; shaft revolves 250 times per minute; diameter of shaft is 4 inches.

For every revolution of the screw the yacht moves forward a distance = 4 feet less 20 per cent = 3.2 feet, and the speed of the yacht in feet per minute = $250 \times 3.2 = 800$.

$$70 \text{ H.P.} = 70 \times 33,000 = 2,310,000 \text{ ft.-lbs. per minute.}$$

This work may be resolved into its factors of force and space, and the propelling force is equal to $2,310,000 \div 800 = 2900$ lbs., nearly.

The shaft is 4 inches in diameter, and the collars must project beyond its surface. Estimate that the mean diameter of the rubbing surface is 4.5 inches, then the mean velocity of rubbing surface would equal $4.5 \times \frac{\pi}{12} \times 250 = 294$ feet per minute. The

allowable value of pressure per square inch of journal surface for a velocity above 200 feet per minute is 50 lbs. The necessary area of the journal surface is therefore = $2900 \div 50 = 58$ square inches.

It has been seen that it is desirable to keep the radial dimension of the collar surface as small as possible in order to have as nearly the same velocity at all parts of the rubbing surface as possible. The width of collar in this case will be assumed = 0.75 inch; then the bearing surface in each collar

$$= \frac{5.5^2 \times \pi}{4} - \frac{4^2 \times \pi}{4} = 23.7 - 12.5 = 11.2 \text{ sq. in.}$$

Then the number of collars equals the total required area divided by the area of each collar = $58 \div 11.2 = 5.18$, say 6.

139. Bearings and Boxes.—The function of a bearing or box is to insure that the journal with which it engages shall have an accurate motion of rotation or vibration about the given axis. It must therefore fit the journal without lost motion; must

afford means of taking up the lost motion that results necessarily from wear; must resist the forces that come upon it through the journal, without undue yielding; must have the wearing surface of such material as will run in contact with the material of the journal with the least possible friction and least tendency to heating and abrasion; and must usually include some device for the maintenance of the lubrication. The selection of the materials and the providing of sufficient strength and stiffness depends upon principles already considered, and so it remains to discuss the means for the taking up of necessary wear and for providing lubrication.

Boxes are sometimes made solid rings or shells, the journal being inserted endwise. In this case the wear can only be taken up by making the engaging surfaces of the box and journal conical, and providing for endwise adjustment either of the box itself or of the part carrying the journal. Thus, in Fig. 129, the collars for the preventing of end motion while running are jam-nuts, and looseness between the journal and box may be taken up by moving the journal axially toward the left.

By far the greater number of boxes, however, are made in sections and the lost motion is taken up by moving one or more sections toward the axis of rotation. The tendency to wear is usually in one direction, and it is sufficient to divide the box

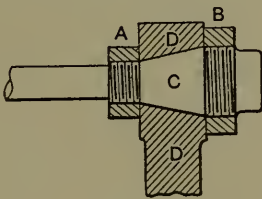

FIG. 129.

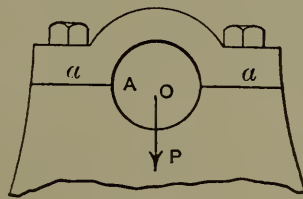

FIG. 130.

into halves. Thus, in Fig. 130, the journal rotates about the axis O , and all the wear is due to the pressure P acting in the direction shown. The wear will therefore be at the bottom of the box. It will suffice for the taking up of wear to dress off

the surfaces at *aa*, and thus the box-cap may be drawn further down by the bolts, and the lost motion is reduced to an admissible value. "Liners," or "shims," which are thin pieces of sheet metal, may be inserted between the surfaces of division of the box at *aa*, and may be removed successively for the lowering of the box-cap as the wear renders it necessary. If the axis of the journal must be kept in a constant position, the lower half of the box must be capable of being raised.

Sometimes, as in the case of the box for the main journal of a steam-engine shaft, the direction of wear is not constant. Thus, in Fig. 131, *A* represents the main shaft of an engine. There is a tendency to wear in the direction *B*, because of the weight of the shaft and its attached parts; there is also a tendency to wear because of the pressure that comes through the connecting-rod and crank. The direction of this pressure is continually varying, but the average directions on forward and

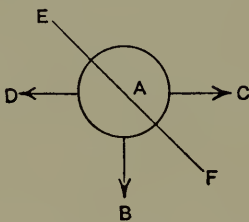

FIG. 131.

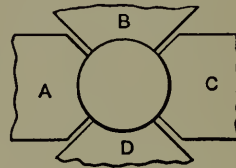

FIG. 132.

return stroke may be represented by *C* and *D*. Provision needs to be made, therefore, for the taking up of wear in these two directions. If the box be divided on the line *EF*, wear will be taken up vertically and horizontally by reducing the liners. Usually, however, in the larger engines the box is divided into four sections, *A*, *B*, *C*, and *D* (Fig. 132), and *A* and *C* are capable of being moved toward the shaft by means of screws or wedges, while *D* may be raised by means of the insertion of "shims."

The lost motion between a journal and its box is sometimes

taken up by making the box as shown in Fig. 133. The external surface of the box is conical and fits in a conical hole in the machine frame. The box is split entirely through at *A*, parallel to the axis, and partly through at *B* and *C*. The ends of the box are threaded, and the nuts *E* and *F* are screwed on. After the journal has run long enough so that there is an unallowable amount of lost motion, the nut *F* is loosened and *E* is screwed up, the effect being to draw the conical box further into the conical hole in the machine frame; the hole

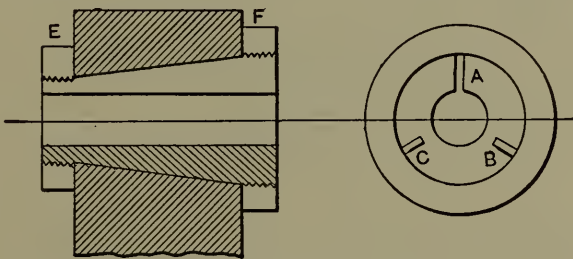

FIG. 133.

through the box is thereby closed up and lost motion is reduced. After this operation the hole cannot be truly cylindrical, and if the cylindrical form of the journal has been maintained, it will not have a bearing throughout its entire surface. This is not usually of very great importance, however, and the form of box has the advantage that it holds the axis of the journal in a constant position. As far as is possible the box should be so designed as to exclude all dust and grit from the bearing surfaces.

All boxes in self-contained machines, like engines or machine tools, need to be rigidly supported to prevent the localization of pressure, since the parts that carry the journals are made as rigid as possible. In line shafts and other parts carrying journals, when the length is great in comparison to the lateral dimensions, some yielding must necessarily occur, and if the boxes were rigid, localization of pressure would result. Hence "self-

adjusting" boxes are used. A point in the axis of rotation at the center of the length of the box is held immovable, but the box is free to move in any way about this point, and thus adjusts itself to any yielding of the shaft. This result is attained as shown in Fig. 134. O is the center of the motion of the box;

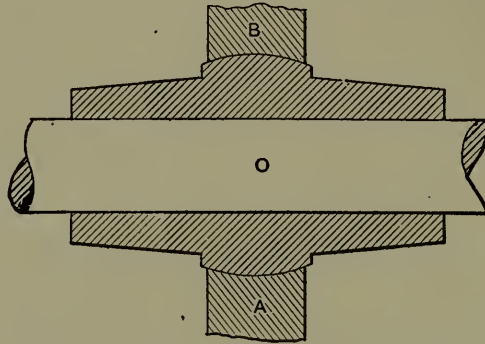

FIG. 134.

B and A are spherical surfaces formed on the box, their center being at O . The support for the box contains internal spherical surfaces which engage with A and B . Thus the point O is always held in a constant position, but the box itself is free to move in any way about O as a center. Therefore the box adjusts itself within limits to any position of the shaft and hence the localization of pressure is impossible.

In thrust-bearings for vertical shafts the weight of the shaft and its attached parts serves to hold the rubbing surfaces in contact and the lost motion is taken up by the shaft following down as wear occurs. In collar thrust-bearings for horizontal shafts the design is such that the bearing for each collar is separate and adjustable. The pressure on the different collars may thus be equalized.*

140. Lubrication of Journals.—The best method of lubrication is that in which the rubbing surfaces are constantly submerged in a bath of lubricating fluid. This method should be

* For complete and varied details of marine thrust-bearings see "Maw's Modern Practice in Marine Engineering."

employed wherever possible if the pressure and surface velocity are high. Unfortunately it cannot be used in the majority of cases. It is not necessary that the whole surface be submerged. If a part of the moving surface runs in the oil-bath it is sufficient.*

Let *J*, Fig. 135, represent a journal with its box, and let *A*, *B*, and *C* be oil-holes. If oil is introduced into the hole *A*, it

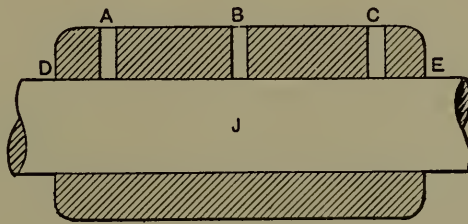

FIG. 135.

will tend to flow out from between the rubbing surfaces by the shortest way, *i.e.*, it will come out at *D*. A small amount will probably go toward the other end of the box because of capillary attraction, but usually none of it will reach the middle of the box. If oil be introduced at *C*, it will come out at *E*. A constant feed, therefore, might be maintained at *A* and *C*, and yet the middle of the box might run dry. If the oil be introduced at *B*, however, it tends to flow equally in both directions, and the entire journal is lubricated. The conclusion follows that oil ought, when possible, to be introduced at the middle of the length of a cylindrical journal. It should be introduced as far as possible from the side where the forces press the journal and box closest together.* If a conical journal runs at a high velocity, the oil under the influence of centrifugal force tends to go to the large end of the cone, and therefore the oil should be introduced at the small end to insure its distribution over the entire journal surface.

* Tower's experiments, Proc. Inst. M. E., 1883 and 1885.

If the end of a vertical thrust-journal whose outline is a cone or tractrix, as in Fig. 136, dips into a bath of oil, *B*, the oil will be carried by its centrifugal force, if the velocity be high, up between the rubbing surfaces, and will be delivered into the groove *AA*. If holes connect *A* and *B*, gravity will return the oil to *B*, and a constant circulation will be maintained. If the thrust-journal has simply a flat end, as in Fig. 137, the oil should be supplied at the center of the bearing; centrifugal force will then distribute it over the entire surface. If the oil is forced in under a pressure sufficient to "float" the shaft the friction will be greatly reduced. Vertical shaft thrust-journals may usually be arranged to run in an oil-bath. Marine collar thrust-journals are always arranged to run in an oil-bath.

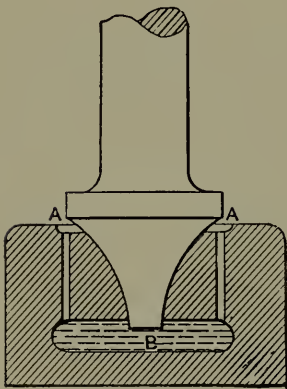

FIG. 136.

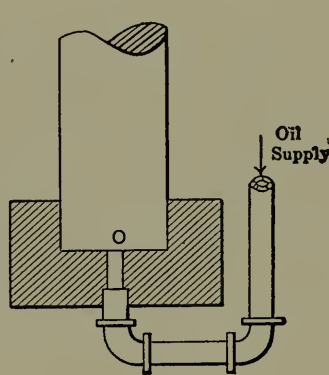

FIG. 137.

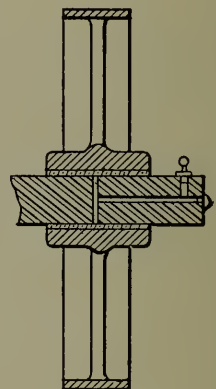

FIG. 138.

Sometimes a journal is stationary, and the box rotates about it, as in the case of a loose pulley, Fig. 138. If the oil is introduced into a tube, as is often done, its centrifugal force will carry it away from the rubbing surface. But if a hole is drilled in the axis of the journal, the lubricant introduced into it will be carried to the rubbing surfaces as required. If a journal is carried in a rotating part at a considerable distance from the axis of rotation, and it requires to be oiled while in motion, a channel may be provided from the axis of rota-

tion, where oil may be introduced conveniently, to the rubbing surfaces, and the oil will be carried out by centrifugal force. Thus Fig. 139 shows an engine-crank in section. Oil is introduced at *b*, and centrifugal force carries it through the channel provided to *a*, where it serves to lubricate the rub-

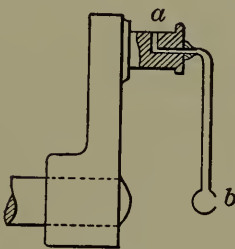

FIG. 139.

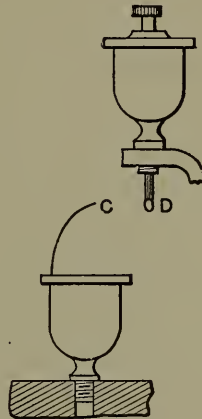

FIG. 140.

bing surfaces of the crank-pin and its box. If a journal is carried in a reciprocating machine part, and requires to be oiled while in motion, the "wick-and-wiper" method is one of the best. (See Fig. 140.) An ordinary oil-cup with an adjustable feed is mounted in a proper position opposite the end of the stroke of the reciprocating part, and a piece of flat wick projects from its delivery-tube. A drop of oil runs down and hangs suspended at its end. Another oil cup is attached to the reciprocating part, which carries a hooked "wiper," *C*. The delivery-tube from *C* leads to the rubbing surfaces to be lubricated. When the reciprocating part reaches the end of its stroke the wiper picks off the drop of oil from the wick and it runs down into the oil-cup *C*, and thence to the surfaces to be lubricated. This method applies to the oiling of the cross-head pin of a steam-engine. The same method is sometimes applied to the crank-pin, but here, through a part

of the revolution, the tendency of the centrifugal force is to force the oil out of the cup, and therefore the plan of oiling from the axis is probably preferable.

When journals are lubricated by feed-oilers, and are so located as not to attract attention if the lubrication should fail for any reason, "tallow-boxes" or "grease-cups" are used. These are cup-like depressions usually cast in the box-cap and communicating by means of an oil-hole with the rubbing surface. These cups are filled with grease that is solid at the ordinary temperature of the box, but if there is the least rise in temperature because of the failure of the oil-supply, the grease melts and runs to the rubbing surfaces, and supplies the lubrication temporarily. This safety device is used very commonly on line-shaft journals.

The most common forms of feed-oilers are: I. The oil-cup with an adjustable valve that controls the rate of flow. II. The oil-cup with a wick feed (Fig. 141). The delivery has a tube

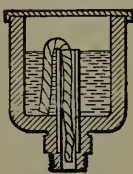

FIG. 141.

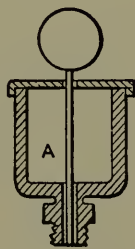

FIG. 142.

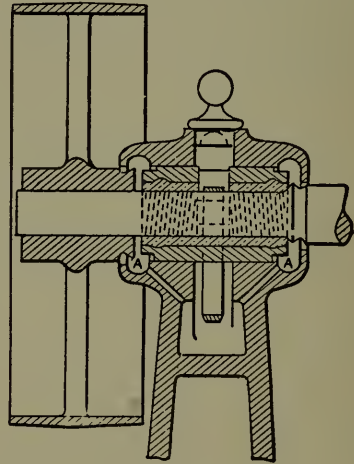

FIG. 143.

inserted in it which projects nearly to the top of the cup. In this tube a piece of wicking is inserted, and its end dips into the oil in the cup. The wick, by capillary attraction, carries the oil slowly and continuously over through the tube to the

rubbing surfaces. III. The cup with a copper rod (Fig. 142). The oil-cup is filled with grease that melts with a very slight elevation of temperature, and *A* is a small copper rod dropped into the delivery-tube and resting on the surface of the journal. The slight friction between the rod and the journal warms the rod and it melts the grease in contact with it, which runs down the rod to the rubbing surface. IV. Sometimes a part of the surface of the bottom half of the box is cut away and a felt pad is inserted, its bottom being in contact with an oil-bath. This pad rubs against the surface of the journal, is kept constantly soaked with oil, and maintains lubrication.

Ring-and-chain lubrication may be considered as special forms of bath lubrication. Fig. 143 shows a ring oiling bearing.

A loose ring rests on top of the journal, the upper box being cut away to permit this; the ring surrounds the lower box and extends into a reservoir filled with oil. The rotation of the shaft carries the ring with it, which, in turn, brings up a constant supply of oil from the reservoir. The annular spaces *A-A* catch all oil which works out along the shaft and return it to the reservoir.

CHAPTER XIII.

ROLLER- AND BALL-BEARINGS.

141. General Considerations.—By substituting rolling motion in bearings in place of relative sliding, friction losses can be greatly reduced. In the design of such bearings there are four points to be borne in mind:

I. The arrangement of the parts and their form must be such that their relative motion is true rolling with the least possible amount of sliding.

II. The form of the constraining surfaces must be such that the rolling parts will not have any effective tendency to leave their proper guides or “races.”

III. The rollers and balls must not be unduly loaded.

IV. Provision must be made to admit the lubricant, and to exclude all dust and grit.

These points will be considered in the order given.

142. I. Rolling, Sliding, and Spinning. (See Fig. 144.)—At

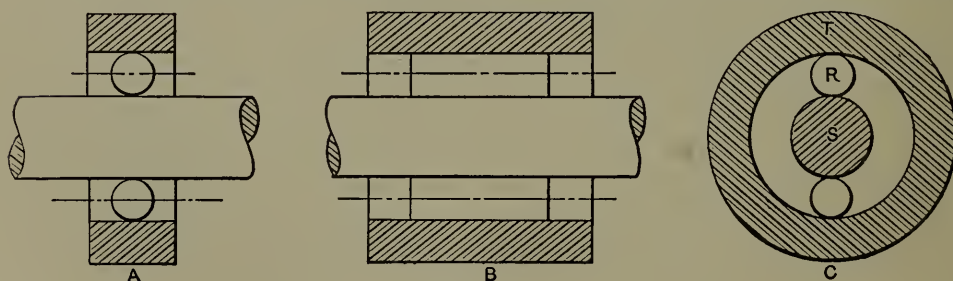

FIG. 144.

A is shown the longitudinal section of a cylindrical ball-bearing of the simplest form stripped of all auxiliary parts. At *B*

is shown the same for a roller-bearing. At C is a cross-section of either, showing but one ball or roller R . S is the journal and T the box. Consider T as stationary, then the point of contact of R and S would have the same motion relative to T whether considered as a point of R or of S , and if the surface friction were sufficient there would be no reason for slippage. As a matter of fact, in the actual bearing there will be a slight amount of slipping at both of the points of contact. This form of bearing is called the "two-point bearing," because there are two points of contact. All cylindrical roller-bearings are of this fundamental form. In order to have them of practical use the rollers must be held in a case or "cage" so that their axes will always remain parallel with the axis of the shaft. Fig. 145 shows such a "cage" with rollers in place.

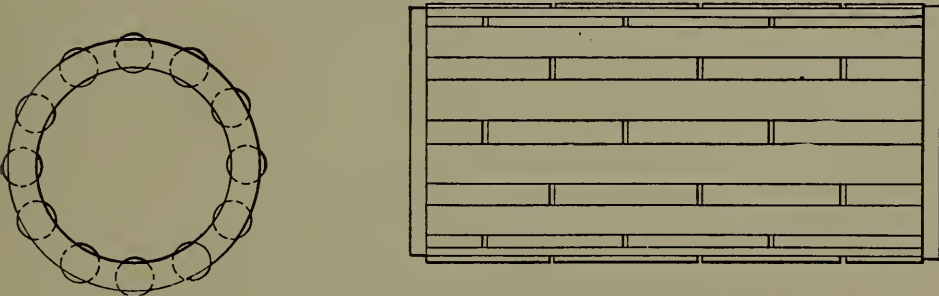

FIG. 145.

Since the rollers are generally of hardened and ground steel the best service with the least wear will be given when the engaging surfaces are of the same material. To meet this when the shaft is of soft steel, say, and the box of cast iron, a hardened and ground-steel ring is fitted over the shaft as a shell and another inside the box as a bushing, and the rollers run between the outer surface of the former and the inner surface of the latter.

Ball-bearings are subject to an action known as "spinning." To illustrate this, consider the three-point ball-bearing shown

in Fig. 146. Here the centros are as shown in *B*, and the conditions are correct for theoretical rolling as long as point contact is maintained and axis *C-D* remains parallel to axis *E-F*. But when the bearing is in use the points of contact, on each side of *R*, with *T* become small areas, as shown in *B*. Considering the relative motion of *R* and *T* at any instant it will be seen that

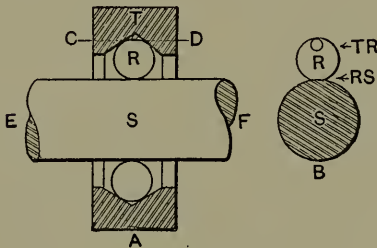

FIG. 146.

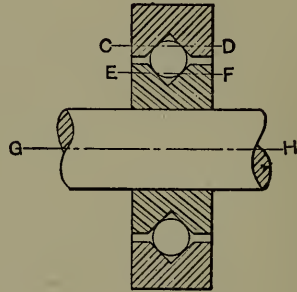

FIG. 147.

there is an action on each side of the ball akin to that of a small thrust-bearing. The rubbing produced in this manner naturally causes undesirable friction. This is the action known as "spinning."

Obviously it is even more marked in the case of a four-point bearing, as shown in Fig. 147.

Here, also, there is pure rolling motion as long as point contact is maintained, and the axes *C-D* and *E-F* remain parallel to axis *G-H*; but as soon as the load is applied the points of contact become areas, and "spinning" results at four surfaces. Experiments bear out the conclusion that a properly designed two-point bearing will have less friction than a three-point, and a three-point will have less than a four-point.

In a "race" whose radius of curvature is just equal to that of the ball the friction becomes excessive. Such races should never be used. (See Fig. 148.)

A force acting at the surface of a ball will tend to rotate it about an axis parallel to the tangent plane in which the actu-

ating force lies; furthermore, this axis will be at a right angle with the direction of the force. This is true because it is merely a special application of the general law that a force applied to a body will tend to move it in the direction of action of the force.

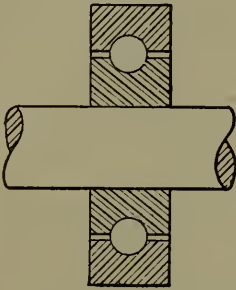

FIG. 148.

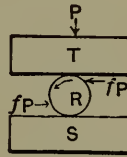

FIG. 149.

The general law for the form of rolling bearings may now be stated as follows:

For true rolling, the constraining surfaces of the journal and box (*i.e.*, the “races”) must be so formed that the axes of rotation of the rollers or balls will all intersect the main axis of the bearing at a fixed point throughout the complete revolution of the journal. This may be made clear by examples.

Fig. 149 shows a ball or roller R held between two similar plates T and S . The upper plate, T , presses down on R with a force P which is transmitted through R to S .

By the principles of so-called “rolling friction,” to roll T on R will require a force fP (*i.e.*, proportional to P) to overcome the resistance. The motion of T on R causes R to roll on S , to which rolling there is induced a resistance also equal to fP , but in the opposite direction as regards R . These two forces being equal, opposite, and applied at the same distance from the center of R , form a couple whose effect would be to give R a motion of rotation about an axis through its center, and perpendicular to the plane in which they both lie.

This case is similar to those shown in Fig. 144, except that

in the cases there shown S and T are not plane surfaces. Each ball in case A and each roller in case B tends to rotate about an axis (relatively to the "cage," not shown) as indicated by the dotted lines. In both cases the individual axes all intersect the main axis of the journal at a fixed point, namely, at infinity, throughout the revolution. The general law for true rolling is therefore fulfilled.

In the cases shown in Figs. 146 and 147, obviously the same conditions hold.

Next consider the thrust-bearings shown in Fig. 150:

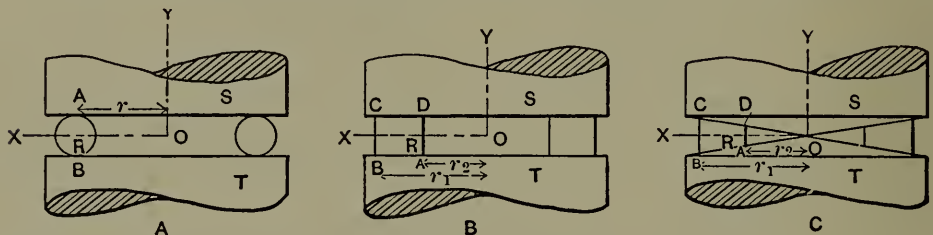

FIG. 150.

Take case A first. S is the moving member, T the stationary member, R one of the balls, and OY is the axis of rotation of S relatively to T . The center of the ball is at any distance r from the axis OY , and its points of contact with S and T are termed A and B respectively. Relatively to the inclosing cage (not shown) all parts of the ball in obedience to the acting force tend to rotate about the axis OX which always cuts OY at O . It is not essential that the angle XOY be a right angle; it is essential that a line joining A and B should pass through the center of R and be perpendicular to OX . It is obvious that the conditions for true rolling are fulfilled.

As OX completes one revolution about OY the ball will rotate about its axis $A-B$ relative to both S and T . Furthermore, since A and B become small areas under the action of the load, it is impossible to avoid the undesirable effect of "spinning."

In case *B*, as *S* rotates relative to *T*, the point *D* common to *R* and *S* will have a linear velocity proportional to r_2 and, similarly, *C*'s linear velocity will be proportional to r_1 . If *AD* and *BC* were two equal, independent circular disks, each would have true rolling motion, and *BC* would make r_1 revolutions, while *AD* would make r_2 . But *BC* and *AD* are both disks of the same roller, *R*, and cannot rotate relative to each other; hence they must each make the same number of revolutions, and points *C* and *D* of the disks would have to have the same velocity, which is inconsistent with the conditions of motions of *C* and *D* as points of *S*. Hence a roller cannot be correctly used for a thrust-bearing. Short rollers securely held in cages are used in practice, but experiments show that they are not as efficient as properly designed forms.*

Consider case *C*. Relative to *T*, the double point *D* will have a linear velocity proportional to r_2 and *C* will have a linear velocity proportional to r_1 . Consider *AD* and *BC* as independent disks so proportioned that $\frac{BC}{AD} = \frac{r_1}{r_2}$. If *D* has a linear velocity proportional to r_2 , then the angular velocity of *AD* about its axis *OX* will be proportional to $\frac{r_2}{\pi AD}$. Similarly, the angular velocity of *BC* about axis *OX* will be proportional to $\frac{r_1}{\pi BC}$.

$$\frac{\text{Angular velocity of } AD}{\text{Angular velocity of } BC} = \frac{\frac{r_2}{\pi AD}}{\frac{r_1}{\pi BC}} = \frac{BC}{AD} \cdot \frac{r_2}{r_1} = \frac{r_1}{r_2} \cdot \frac{r_2}{r_1} = 1,$$

since $\frac{BC}{AD} = \frac{r_1}{r_2}$.

Hence the disks *AD* and *BC* have the same angular velocity about the axis *OX*, and may form parts of the same body.

* See article by T. Hill in American Machinist, Jan. 5, 1899.

This will be true of any pair of disks of the cone OBC . Any frustrum of a cone whose apex lies anywhere on the axis OY will therefore fulfill the conditions for true rolling motion relatively to T when actuated by S .

In each of the foregoing cases the rolling members must be held in suitable "cages," or they will yield to the tendency to displace them.

In ball thrust-bearings it is desirable to so arrange the balls in the cage that each one will have a separate path, as this minimizes wear.

For a three-point thrust ball-bearing the form of the races to permit true rolling must be as shown in Fig. 151 to be in accordance with the principles just demonstrated. The groove-angle should be as flat as possible to reduce the friction effect of "spinning."

About 120° will be found a good practicable value.

The ball becomes akin to a cone as far as its relation with T , with which it has two points of contact, is concerned. It remains as a ball as far as its relation with S is concerned. In each case the motion imparted to the ball tends to rotate it about the correct axis OX and the conditions for true rolling are satisfied. The sides of the race are tangent to the ball where it is cut by any line $A-B$ which passes through O .

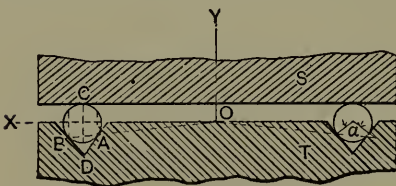

FIG. 151.

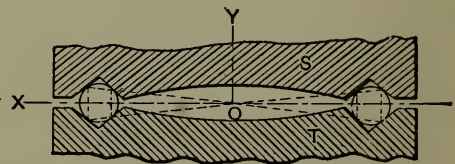

FIG. 152.

A four-point ball-bearing must be designed according to the principles indicated in Fig. 152 for true rolling motion. As far as its motion relations with T and S are concerned, the ball becomes akin to a cone.

Similarly a cup and cone three-point bearing should have the form shown in Fig. 153.

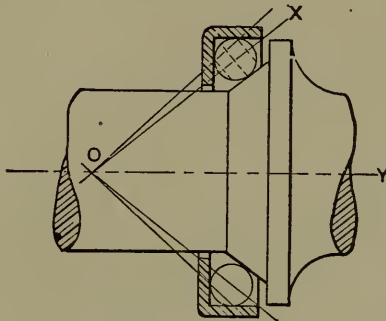

FIG. 153.

143. II. The form of the constraining surfaces must be such in ball-bearings that the balls will not have any effective tendency to leave their proper paths. The use of cages for this purpose has already been mentioned.

If two-point bearings without cages are desired, the section of each race should be the arc of a circle whose radius is $\frac{9}{16}$ to $\frac{3}{4}$ of the diameter of the ball. In two-point bearings the points of pressure must always be diametrically opposite.

In three- and four-point bearings where the races are properly formed for true rolling, as explained in the preceding section, the tendency for the balls to leave the races is reduced to a minimum.

One point, however, needs further consideration. In cup-and cone-bearings it is impossible to keep a tight adjustment at all times, and the least play will allow some of the balls on the unloaded side of the bearing to get out of place.

Fig. 154 shows such a bearing loosely adjusted.

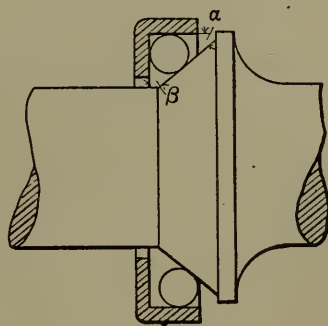

FIG. 154.

The loaded cup is forced down so that its axis lies below the axis of the cone. The top ball is held correctly in place for true

rolling; the lower ball is free to roll to one side as seen. Investigation has shown that the angles α and β should each be at least as great as 25° in order to return the displaced ball easily to its proper path by the time it becomes subjected to the load. If the angles are too acute there is a tendency for the balls to wedge in their incorrect positions, causing rapid wear or even crushing.*

144. III. Allowable Loading.—Careful experiments show that for high efficiency and durability the loads on balls and rollers should be very much less than they could be with safety as far as their strength is concerned.†

Let P_0 equal the load in pounds which is allowable for a single ball or roller. Then for balls

$$P_0 = Kd^2,$$

d = diameter of ball in inches.

$K = 1500$ for hardened steel balls and races, two-point bearing.
 $K = 750$ for hardened steel balls and races, three- and four-point bearing.

For cast-iron balls and races use two-fifths of these values.

For rollers

$$P_0 = Kdl.$$

d = diameter of roller in inches = mean diameter of cone,

l = length of roller in inches,

$K = 400$ for cast iron,

$K = 1000$ for hardened steel.

In thrust-bearings, if the total load = P and the number of balls = n , we have for either balls or rollers

$$P_0 = \frac{P}{n}.$$

* See article by R. Janney in *American Machinist*, Jan. 5, 1899.

† See excellent article by Professor Stribeck in *Z. d. V. d. I.*, Jan. 19 and 26, 1901.

In cylindrical bearings the load is always greatest at one side of the bearing, the balls or rollers on the opposite side being entirely unloaded. It has been found that the load on the heaviest loaded ball or roller = $P_0 = \frac{5}{n}P$, where n is the number of balls.

145. Size of Bearing.—To determine the size of the ball circle (*i.e.* the middle diameter of the “race”) given the number of balls n and their diameter d . (See Fig. 155.)

r = radius of ball. R = radius of ball circle. Join the centers of two consecutive balls by the chord $AB = 2r$. From the center of the ball circle, O , draw two radii, one to A and the other to the mid-point of $A-B$. Call the angle included between the radii α . Then

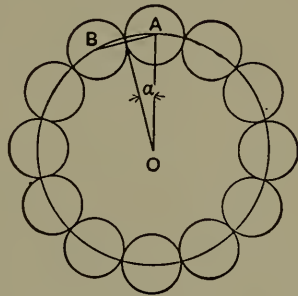

FIG. 155.

$$r = R \sin \alpha, \text{ and,}$$

since
$$\alpha = \frac{180^\circ}{n},$$

$$R = \frac{r}{\sin \frac{180^\circ}{n}}.$$

This is the radius of a circle on which the centers of the balls will lie when their surfaces are all in contact. It is desirable to allow some clearance between the balls. This may be as much as 0.005 inch between each pair of balls provided the total allowance does not exceed $\frac{d}{4}$. When the total clearance has been decided upon, it may be allowed for by making the actual radius of the ball circle larger than R by an amount one sixth of the total clearance desired.

146. IV. **Lubrication and Sealing.**—On account of “spinning,” faulty adjustment, and unavoidable slippage, rolling bearings should be properly lubricated. As they are extremely sensitive to the presence of dust and grit, care must be exercised that the lubricant be admitted without any danger of the entrance of these.

Sealed oil-holes, dust-caps, and felt washers are commonly used both to retain the lubricant for bath lubrication and for keeping out all dirt.

CHAPTER XIV.

COUPLINGS AND CLUTCHES.

147. **Couplings and Clutches Defined.**—Couplings are those machine parts which are used to connect the ends of two shafts or spindles in such a manner that rotation of the one will produce an identical rotation of the other. They are therefore in the nature of fastenings, and may be classified as permanent or disengaging. The latter are frequently called clutches.

148. **Permanent Couplings.**—The simplest form of permanent coupling is shown in Fig. 156, and is known as the “sleeve” or “muff” coupling. Each shaft has a keyway cut

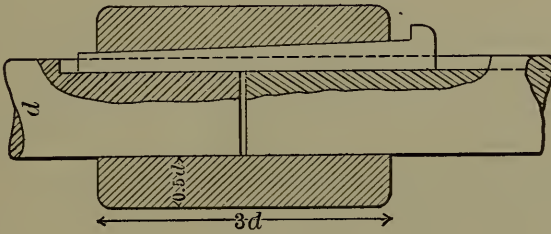

FIG. 156.

at the end. The cast-iron sleeve of the proportions indicated is bored an exact fit for the shafts and has a keyway cut its entire length. When the sleeve is slipped over the ends of the shafts, the key is driven home and all relative rotation is prevented. The key may be proportioned according to the rules laid down in the chapter on Means for Preventing Relative Rotation.

149. Flange couplings are frequently used, and Fig. 157 illustrates the type. Approximate proportions are indicated.

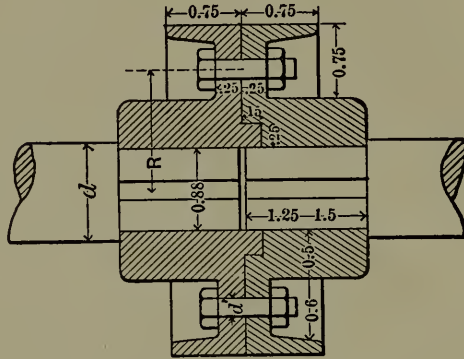

FIG. 157.

The number of bolts n may be from $3 + 0.5d$ to $3 + d$. Their diameter d' must be such that their combined strength to resist a torsional moment about the axis of the shaft will be equal to the torsional strength of the shaft,

$$\therefore j_s \frac{\pi d^3}{16} = Rn \frac{\pi d'^2}{4} j_s'.$$

j_s = allowable stress in outer fiber of shaft, pounds per square inch;

d = diameter of shaft, inches;

R = radius of bolt circle, inches;

n = number of bolts;

d' = diameter of bolts, inches;

j_s' = allowable shearing stress in bolts, pounds per square inch.

This equation will approximately give

$$d' = \frac{.5d}{\sqrt{n}}.$$

150. Compression couplings of three forms are shown in Figs. 158, 159, and 160. The first is similar to the ordinary

sleeve coupling except that the sleeve is split in halves longitudinally and is tapered toward each end on the outside. The two rings shown are driven or shrunk on these tapers.

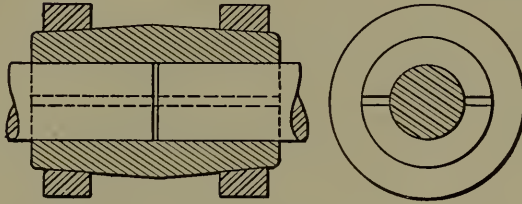

FIG. 158.

Instead of being held by rings the half sleeves are sometimes bolted together as shown in Fig. 159.

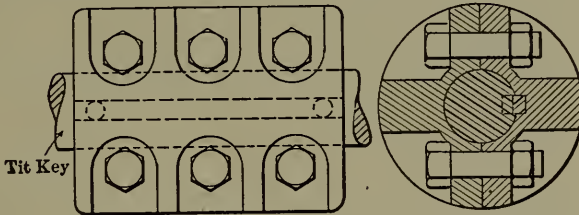

FIG. 159.

151. The "Sellers" coupling is shown in Fig. 160. An outer sleeve *A* is bored tapering from each end. A split cone bushing *B* is inserted at each end. Openings are left for three

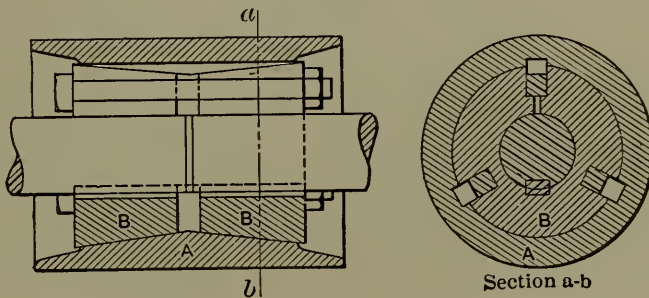

FIG. 160.

bolts by means of which *B* and *B* are drawn toward each other and thus closed down on the shaft with great force. A key is also provided.

152. **Oldham's Coupling.**—For all of the foregoing couplings the axes of the two shafts must be identical. Where the

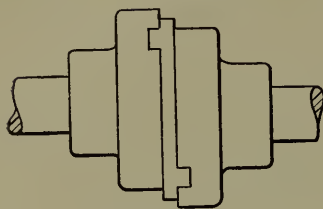

FIG. 161.

axes are parallel, Oldham's coupling may be used. It is shown in Fig. 161, and consists of three parts. Each shaft end has keyed to it a flange or disk which has a diametral groove cut across its face. Between these two disks is a third which has a tongue on each face. The tongues, which just fit the grooves freely, run diametrically across the disk and are at a right angle with each other.

153. **Hooke's Coupling.**—For axes which intersect, Hooke's coupling or "universal joint" may be used. It is shown in outline in Fig. 162. Each shaft has a stirrup keyed to its end.

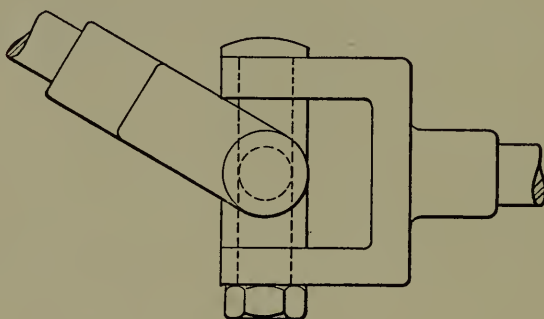

FIG. 162.

Each stirrup is connected by turning pairs to a cross-shaped intermediate member, the axes of whose turning pairs are at a right angle. For a mathematical analysis of this mechanism the reader is referred to Professor Kennedy's "Mechanics of Machinery."

154. **Flexible Couplings.**—Where shafts which are or which may become slightly out of alignment are to be connected, some form of flexible coupling is advisable. Their principle is illustrated in Fig. 163. Each shaft has keyed to its end a

disk which has set in its face a number of pins. The pins are so placed that those in the one circle will not strike those in the other if either shaft is rotated while the other remains at rest. When one shaft is to drive the other, short belts are placed on the pins as shown in *B*, Fig. 163.

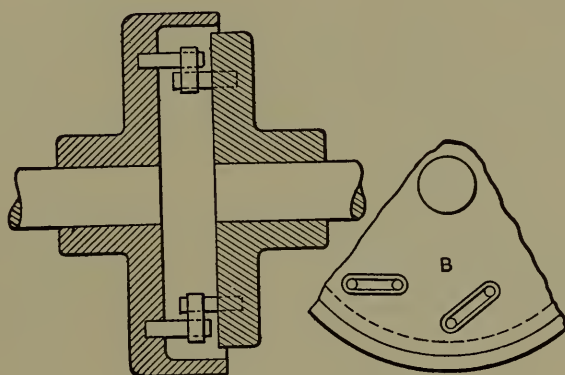

FIG. 163.

155. Disengaging couplings are of two general classes: positive drive and friction drive. Positive-drive couplings are commonly called toothed or claw couplings. They consist of two members having projections on their faces, as shown in Fig. 164, which interlock when in action. *A* is keyed rigidly

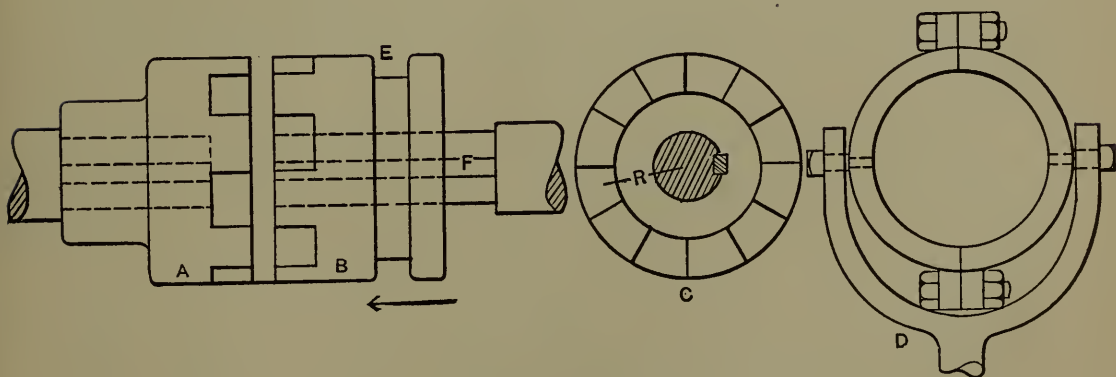

FIG. 164.

to its shaft. *B* can slide along its shaft guided by the feather, *F*, but cannot rotate except with the shaft. When *B* is moved

in the direction of the arrow, its teeth engage with those of A , and the two shafts must have the same motion of rotation. D shows the end of the lever which moves B . The split ring is bolted around B in the groove E , which it fits freely. Sometimes short blocks which fit E are used in place of the entire ring. C shows an end view of the half clutch.

Various forms of teeth may be used.* If n equals the number of teeth and R equals the mean radius of the clutch tooth the following equations may be written:

$$f_s \frac{\pi d^3}{16} = RnA'f_c,$$

and

$$f_s \frac{\pi d^3}{16} = RnA f_s'.$$

In the first equation, $f_s \frac{\pi d^3}{16}$, the torsional strength of the shaft, is equated to the crushing resistance of all the teeth opposed to the torsional stress. A' is the area of the engaging face of one tooth and f_c the allowable unit crushing stress.

In the second equation A is the area of the root of the tooth subjected to shear and f_s' is the allowable unit shearing stress.

156. Friction couplings generally consist of two parts, a hollow cone, A , keyed rigidly to one shaft, and a sliding cone, B , held by a feather on the second shaft as seen in Fig. 165. By means of a lever, B can be forced against A with a considerable axial pressure. This induces friction between the conical surfaces, which friction resists relative rotation. To analyze the forces, consider Fig. 166 which shows two conical

* See article in American Machinist, July 9, 1903.

surfaces pressed together by an axial force P . The angle at the vertex of the cone is 2α .

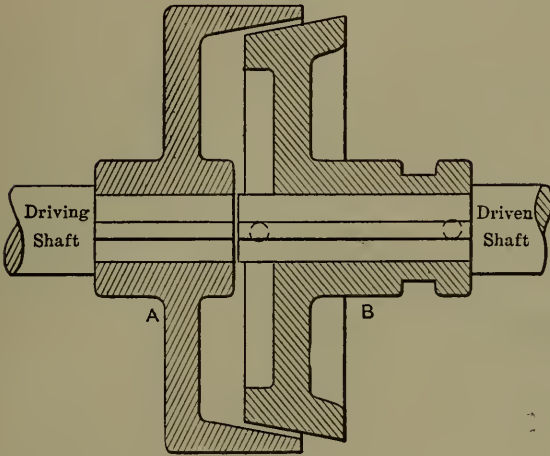

FIG. 165.

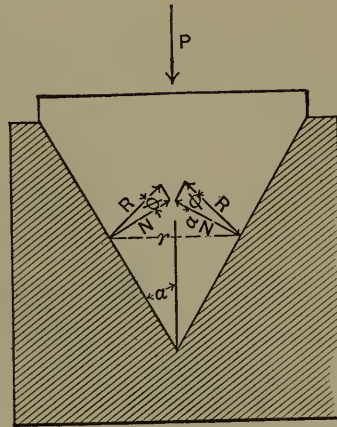

FIG. 166.

Let the coefficient of friction $= \mu = \tan \phi$.

The mean cone radius $= r$.

Total pressure between the two surfaces for impending slippage $= 2R$.

Total normal pressure between two surfaces at rest $= 2N$.

Total friction $= F = \mu 2N$.

It is clear from the figure that $P = 2R \sin (\alpha + \phi)$.

Also, $N = R \cos \phi$.

$$\therefore P = \frac{2N \sin (\alpha + \phi)}{\cos \phi}.$$

But $2N = \frac{F}{\mu}$, where F = friction force between the surfaces.

$$\therefore P = \frac{F}{\mu} (\sin \alpha + \mu \cos \alpha).$$

From this equation and the fact that the turning moment, $M = Fr$, the clutch can be designed to transmit the desired power.

The angle α should lie between 5° and 10° in order to avoid "sticking" on the one hand and too sudden seizure on the other.

TABLE XVIII.

$\mu = 0.10$ to 0.15	for cast iron on cast iron
$= 0.15$ to 0.20	for cast iron on paper
$= 0.20$ to 0.30	for cast iron on leather
$= 0.20$ to 0.50	for cast iron on wood.

157. **Weston Friction Coupling.**—For heavy duty the principle of the Weston friction coupling, as shown in Fig. 167, may

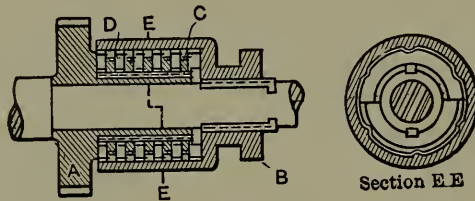

FIG. 167.

be used. The sleeve *A* carries two feathers on which a number of iron rings *C* can slide but not rotate. Similarly the hollow sleeve *B* is provided with feathers which prevent the rotation of the wooden rings *D*, while not interfering with their sliding.

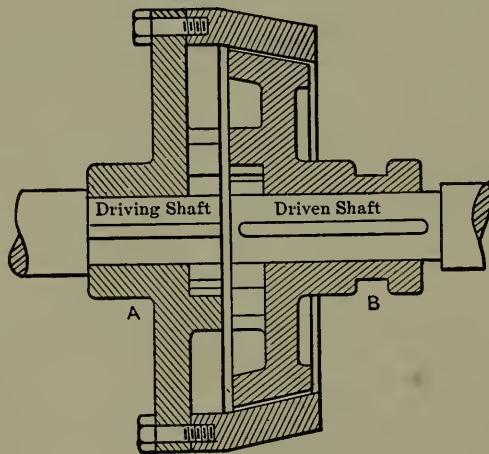

FIG. 168.

Let there be n iron rings. Then, when *B* is pressed toward *A*, there will be friction induced on $2n+1$ surfaces. If P is the axial pressure and μ the coefficient of friction, the total

friction $F = \mu P(2n + 1)$, and if r = the mean radius of the rings, the moment which can be transmitted $= M = Fr$.

158. A combination friction- and claw-clutch is shown in Fig. 168. To start the driven shaft, B is forced to the right, thus bringing the friction cones into action. When the driven shaft has attained its proper speed, B is suddenly shifted to the left, thus causing the claw-clutch to engage, which gives the advantage of positive driving.

CHAPTER XV.

BELTS.

159. **Transmission of Motion by Belts.**—In Fig. 169, let A and B be two cylindrical surfaces, free to rotate about their axes; let CD be their common tangent, and let it represent an inextensible connection between the two cylinders. Since it is inextensible, the points D and C , and hence the surfaces of the

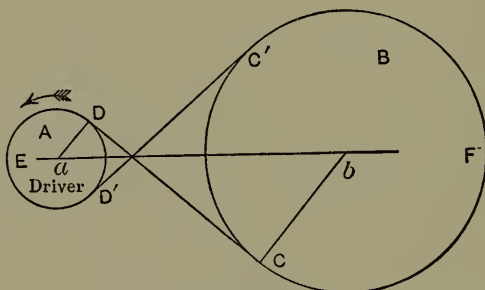

FIG. 169.

cylinders, must have the same linear velocity when A is rotated as indicated by the arrow. Two points having the same linear velocity, and different radii, have angular velocities which are inversely proportional to their radii. Hence, since the surfaces of the cylinders have the same linear velocity, their angular velocities are inversely proportional to their radii. This is true of all cylinders connected by inextensible connectors. Suppose the cylinders to become pulleys, and the tangent line to become a belt. Let $C'D'$ be drawn; this becomes a part of the belt together with the portions DED' and CFC' , making it endless, and rotation may be continuous. The belt will remain always tangent to the pulleys, and will transmit such rotation that the

angular velocity ratio will constantly be the inverse ratio of the radii of the pulleys.

The case considered corresponds to a crossed belt, but the same reasoning applies to an open belt. (See Fig. 170.) *A* and

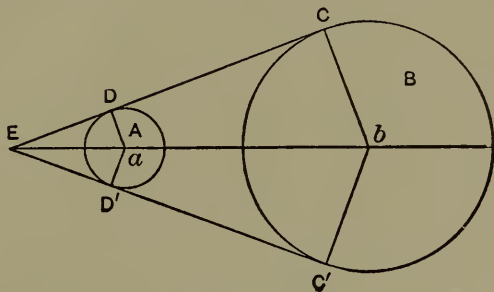

FIG. 170.

B are two pulleys, and *CDD'C'C* is an open belt. Since the points *C* and *D* are connected by a belt that is practically inextensible, the linear velocity of *C* and *D* is the same; therefore the angular velocities of the pulleys are to each other inversely as their radii. If the pulleys in either case were pitch cylinders of gears the condition of velocity would be the same. In the first case, however, the direction of motion is reversed, while in the second case it is not. Hence the first corresponds to gears meshing directly with each other, while the second corresponds to the case of gears connected by an idler, or to the case of an annular gear and pinion. While in many places positive driving-gears are indispensable, it is frequently the case that the relative position of the axes to be connected is such as would demand gears of inconvenient or impossible proportions, and belts are used with the sacrifice of positive driving.

Of course it is necessary that a belt should have some thickness; and, since the center of pull is the center of the belt, it is necessary to add to the radius of the pulley half the thickness of the belt. The motion communicated by means of belting, however, does not need to be absolutely correct, and therefore in practice it is usually customary to neglect the thickness of the

belt. The proportioning of pulleys for the transmission of any required velocity ratio is now a very simple matter.

160. Illustration.—A line-shaft runs 150 revolutions per minute, and is supported by hangers with 16 inches “drop.” It is required to transmit motion from this shaft to a dynamo to run 1800 revolutions per minute. A 30-inch pulley is the largest that can be conveniently used with 16-inch hangers. Let x = the diameter of required pulley for the dynamo; then from what has preceded $x \div 30 = 150 \div 1800$, and therefore $x = 2.5$ inches. But a pulley less than 4 inches diameter should not be used on a dynamo.* Suppose in this case that it is 6 inches. It is then impossible to obtain the required velocity ratio with one change of speed, *i.e.*, with one belt. Two changes of speed

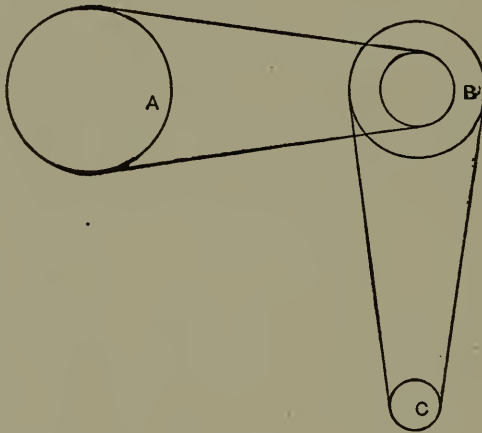

FIG. 171.

may be obtained by the introduction of a counter-shaft. By this means the velocity ratio is divided into two factors. If it is wished to have the same change of speed from the line shaft to the counter as from the counter to the dynamo, then each velocity ratio would be $\sqrt{(1800 \div 150)} = \sqrt{12} = 3.46$. But this gives an inconvenient fraction, and the factors do not need to be

* This limiting size is determined mainly by considerations of thickness of belt required to transmit the energy, its durability, and its efficiency. (See § 171.)

equal. Let the factors be 3 and 4. (See Fig. 171.) *A* represents the line-shaft, *B* the counter, and *C* the dynamo-shaft. The pulley on the line-shaft is 30 inches, and the speed is to be three times as great at the counter, therefore the pulley on the counter connected with the line-shaft pulley must have a diameter one third as great as that on the line-shaft = 10 inches. The pulley on the dynamo is 6 inches in diameter and the counter-shaft is to run one fourth as fast as the dynamo, and therefore the pulley on the counter opposite the dynamo-pulley must be four times as large as the dynamo-pulley = 24 inches.

161. A belt may be shifted from one part of a pulley to another by means of pressure against the side which advances towards the pulley. Thus if, in Fig. 172, the rotation be as indicated by the arrow, and side pressure be applied at *A*, the belt will be pushed to one side, as is shown, and will consequently be carried into some new position on the pulley further to the left as it advances. Hence, in order that a belt may maintain its position on a pulley, THE CENTER LINE OF THE ADVANCING SIDE OF THE BELT MUST BE PERPENDICULAR TO THE AXIS OF ROTATION. When this condition is fulfilled the belt will run and transmit the required motion, regardless of the relative position of the shafts.

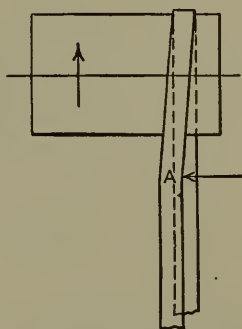

FIG. 172.

162. Twist Belts.—In Fig. 173 the axes *AB* and *CD* are parallel to each other, the above stated condition is fulfilled, and the belt will run correctly; but if the axis *CD* were turned into some new position, as *C'D'*, the side of the belt that advances toward the pulley *E* from *F* cannot have its center line in a plane perpendicular to the axis, *AB*, and therefore it will run off. But if a plane be passed through the line *CD*, perpendicular to the plane of the paper, then the axis may be swung in this plane

in such a way that the necessary condition shall be fulfilled, and the belt will run properly. This gives what is known as a "twist" belt, and when the angle between the shaft becomes 90° , it is a "quarter-twist" belt. To make this clearer, see Fig. 174. Rotation is transmitted from *A* to *B* by an open belt, and it is required to turn the axis of *B* out of parallelism with

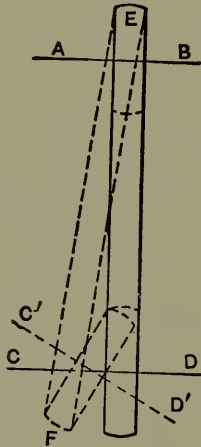

FIG. 173.

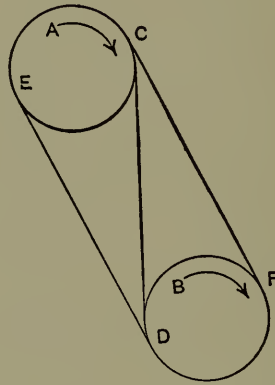

FIG. 174.

that of *A*. The direction of rotation is as indicated by the arrows. Draw the line *CD*. If now the line *CD* is supposed to pass through the center of the belt at *C* and *D*, it may become an axis, and the pulley *B* and the part of the belt *FC* may be turned about it, while the pulley *A* and the part of the belt *ED* remain stationary. During this motion the center line of the part of the belt *CF*, which is the part that advances toward the pulley *B* when rotation occurs, is always in a plane perpendicular to the axis of the pulley *B*. The part *ED*, since it has not been moved, has also its center line in a plane perpendicular to the axis of *A*. Therefore the pulley *B* may be swung into any angular position about *CD* as an axis, and the condition of proper belt transmission will not be interfered with.

163. If the axes intersect the motion can be transmitted

between them by belting only by the use of "guide" or "idler" pulleys. Let AB and CD , Fig. 175, be intersecting axes, and let it be required to transmit motion from one to the other by means of a belt running on the pulleys E and F . Draw center lines EK and FH through the pulleys. Draw the circle, G , of any convenient size, tangent to the lines EK and FH . In the axis of the circle, G , let a shaft be placed on which are two pulleys, their diameters being equal to that of the circle, G .

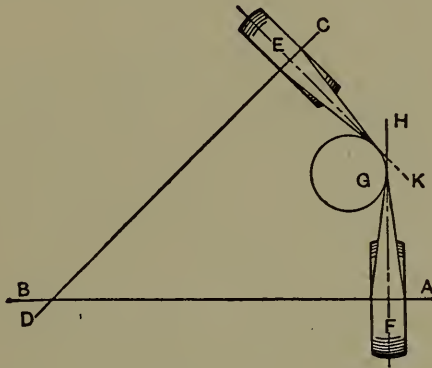

FIG. 175.

These will serve as guide-pulleys for the upper and lower sides of the belt, and by means of them the center lines of the advancing parts of both sides of the belt will be kept in planes perpendicular to the axis of the pulley toward which they are advancing, the belts will run properly, and the motion will be transmitted, as required.

The analogy between gearing and belting for the transmission of rotary motion has been mentioned in an earlier paragraph. Spur-gearing corresponds to an open or crossed belt transmitting motion between parallel shafts. Bevel-gears correspond to a belt running on guide-pulleys transmitting motion between intersecting shafts. Skew bevel and spiral gears correspond to a "twist" belt transmitting motion between shafts that are neither parallel nor intersecting.

164. Crowning Pulleys.—If a flat belt is put on a “crowning” pulley, as in Fig. 176, the tension on AB will be greater than on CD . The belt lying flat at AC will have its approaching portion bent out as indicated by AE and CF , and as rotation goes on the belt will be carried toward the high part of the pulley, *i.e.*,

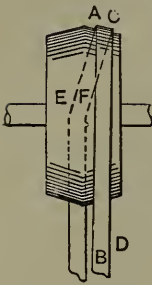

FIG. 176.

it will tend to run in the middle of the pulley. This is the reason why nearly all belt pulleys, except those on which the belt has to be shifted into different positions, are turned “crowning.”

165. Cone Pulleys.—In performing different operations on a machine or the same operations on materials of different degrees of hardness, different speeds are required. The simplest way of obtaining them is by use of cone pulleys. One pulley has a series of steps, and the opposing pulley has a corresponding series of steps. By shifting the belt from one pair to another the velocity ratio is changed. Since the same belt is used on all the pairs of steps, these must be so proportioned that the belt length for all the pairs shall be the same; otherwise the belt would be too tight on some of the steps and too loose on others. Let the case of a crossed belt be first considered. The length of a crossed belt may be expressed by the following formula: Let L = length of the belt; d = distance between centers of rotation; R = radius of the larger pulley; r = radius of the smaller pulley. (See Fig. 177.) Then

$$L = 2\sqrt{d^2 - (R+r)^2} + (R+r)(\pi + 2 \text{ arc whose sine is } (R+r) \div d).$$

In the case of a crossed belt, if the size of steps is changed so that the sum of their radii remains constant, the belt length will be constant. For in the formula the only variables are R and r , and these terms only appear in the formula as $R+r$; but $R+r$ is by hypothesis constant. Therefore any change that is

made in the variables R and r , so long as their sum is constant, will not affect the value of the equation, and hence the belt length will be constant. It will now be easy to design cone pulleys for a crossed belt. Suppose a pair of steps given to transmit a certain velocity ratio. It is required to find a pair of steps that will transmit some other velocity ratio, the length of belt being the same in both cases. Let R and $r =$ radii of the given steps; R' and $r' =$ radii of the required steps; $R + r = R' + r' = a$; the velocity ratio of R' to $r' = b$. There are two

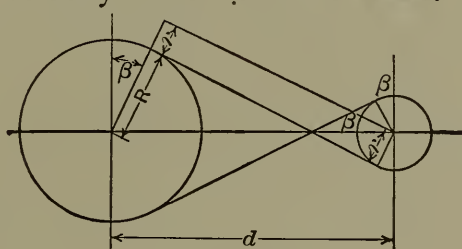

FIG. 177.

equations between R' and r' , $R' \div r' = b$, and $R' + r' = a$. Combining and solving, it is found that $r' = a \div (1 + b)$, and $R' = a - r'$.

For an open belt the formula for length, using same symbols as for crossed belt, is

$$L = 2\sqrt{d^2 - (R - r)^2} + \pi(R + r) + 2(R - r) (\text{arc whose sine is } (R - r) \div d).$$

If R and r are changed as before (*i.e.*, $R + r = R' + r' = a$ constant), the term $R - r$ would of course not be constant, and two of the terms of the equation would vary in value; therefore the length of the belt would vary. The determination of cone steps for open belts therefore becomes a more difficult matter, and approximate methods are almost invariably used.

166. Graphical Method for Cone-pulley Design.—The following graphical approximate method is due to Mr. C. A. Smith, and is given, with full discussion of the subject, in "Transactions

of the American Society of Mechanical Engineers," Vol. X, p. 269. Suppose first that the diameters of a pair of cone steps that transmit a certain velocity ratio are given, and that the diameters of another pair that shall serve to transmit some other velocity ratio are required. The distance between centers of axes is given. (See Fig. 178.) Locate the pulley centers O

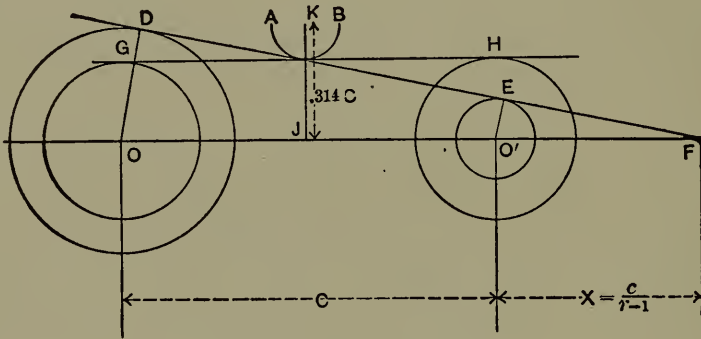

FIG. 178.

and O' at the given distance apart; about these centers draw circles whose diameters equal the diameters of the given pair of steps; draw a straight line GH tangent to these circles; at J , the middle point of the line of centers, erect a perpendicular, and lay off a distance JK equal to the distance between centers, C , multiplied by the experimentally determined constant 0.314 ; about the point K so determined, draw a circular arc AB tangent to the line GH . Any line drawn tangent to this arc will be the common tangent to a pair of cone steps giving the same belt length as that of the given pair. For example, suppose that OD is the radius of one step of the required pair; about O , with a radius equal to OD , draw a circle; tangent to this circle and the arc AB draw a straight line DE ; about O' and tangent to DE draw a circle; its diameter will equal that of the required step.

But suppose that, instead of having one step of the required pair given, to find the other corresponding as above, a pair of

steps are required that shall transmit a certain velocity ratio, $=r$, with the same length of belt as the given pair. Suppose OD and $O'E$ to represent the unknown steps. The given velocity

ratio equals r . Also, $r = \frac{OD}{O'E}$. But from similar triangles

$OD \div O'E = FO \div FO'$. Therefore $r = \frac{FO}{FO'}$; but $FO = C + x$,

and $FO' = x$. Therefore $r = \frac{C + x}{x}$, and $x = \frac{C}{r - 1}$. Hence with

r and C given, the distance x may be found, and a point F located, such that if from F a line be drawn tangent to AB , the cone steps drawn tangent to it will give the velocity ratio, r , and a belt length equal to that of any pair of cones determined by a tangent to AB . The point F often falls at an inconvenient distance. The radii of the required steps may then be found as follows: Place a straight-edge tangent to the arc AB and measure the perpendicular distances from it to O and O' . The straight-edge may be shifted until these distances bear the required relation to each other.

167. Design of Belts.—Fig. 179 represents two pulleys connected by a belt. When no moment is applied tending to produce rotation this tension in the two sides of the belt is practically equal. Let T_3 represent this tension. If now an increasing moment, represented by Rl , be applied to the driver, its effect is to increase the tension in the lower side of the belt and to decrease the tension in the upper side. With the increase of Rl this difference of tension increases till it is equal to P , the force with which rotation is resisted at the surface of the pulley. Then rotation begins* and continues as long as this equality continues; *i.e.*, as long as $T_1 - T_2 = P$, in which T_1 = tension in the driving side and T_2 = tension in the slack

* While the moving parts are being brought up to speed the difference of tension must equal P plus force necessary to produce the acceleration.

side. (See Fig. 180.) The tension in the driving side is increased at the expense of that in the slack side. Therefore $\frac{T_1 + T_2}{2} = T_3$.

To find the value of $\frac{T_1}{T_2}$. The increase in tension from the slack side to the driving side is possible because of the frictional resistance between the belt and pulley surface. Consider any

FIG. 179.

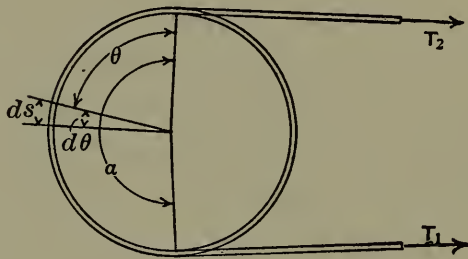
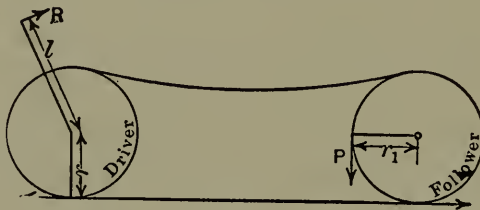

FIG. 180.

element of the belt, ds , Fig. 181. It is in equilibrium under the action of the following forces:

T , the value of the varying tension at one end of ds ;

$T + dT$, the value of the varying tension at the other end of ds ;

cds , the centrifugal force;

pds , the pressure between the face of the pulley and ds ;

$dF = \mu pds$, the friction between the element of belt and pulley face.

Let the value of cds be first determined.

Let A = sectional area of belt in square inches;

T = total tension at any section in pounds;

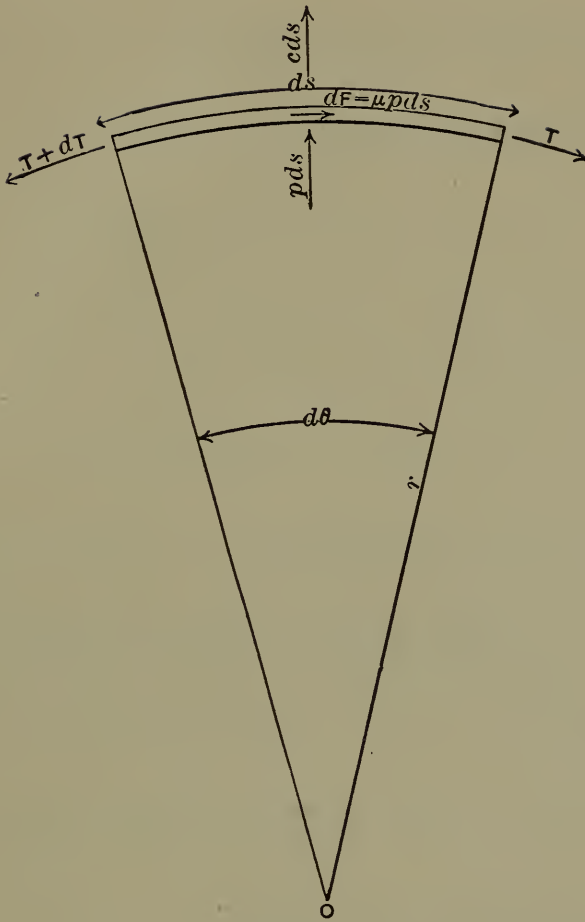

FIG. 181.

t = allowable working tension in pounds per square inch
of cross-section of belt, so that $A = \frac{T}{t}$;

w = weight of belt per cubic inch;

V = velocity of belt in feet per minute;

v = velocity of belt in feet per second;

R = radius of pulley in feet;

r = radius of pulley in inches;

g = acceleration due to gravity = 32.2 feet per second per second;

C = centrifugal force per cubic inch of belt in pounds;

c = centrifugal force per linear inch of belt in pounds.

$$\text{Centrifugal force} = \frac{\text{mass} \times \text{velocity}^2}{\text{radius of curvature}}.$$

$$C = \frac{w v^2}{g R} \text{ in foot-pounds-second system.}$$

$$\therefore c = A \frac{w}{g} \cdot \frac{v^2}{R} = \frac{T}{t} \cdot \frac{w}{g} \cdot \frac{v^2}{R} = \frac{12 w v^2}{g t} \cdot \frac{T}{r}.$$

$$\text{As an abbreviation let } z = \frac{12 w v^2}{g t}.$$

$$\therefore c = T \frac{z}{r}, \text{ and } cds = T \frac{z}{r} ds.$$

Now, to find the value of $\frac{T_1}{T_2}$:

Since dT is small compared with T , no appreciable error is introduced by considering pds as acting normally to the chord of ds , and we may write the equation (sum of vert. comp. = 0, in Fig. 181)

$$pds + cds = T \sin \frac{d\theta}{2} + (T + dT) \left(\sin \frac{d\theta}{2} \right).$$

α = total arc of contact in degrees.

θ is the total arc of contact in radians = 0.0175α .

$d\theta$ is so small that $\sin \frac{d\theta}{2}$ may be considered equal to $\frac{d\theta}{2}$ in radians. Also dT and $d\theta$ both being very small compared to the other quantities, any terms containing their product may be dropped. Therefore

$$pds + cds = Td\theta.$$

$$\therefore pds = Td\theta - cds = Td\theta - T \frac{z}{r} ds.$$

But $ds = rd\theta$.

$$\therefore pds = Td\theta - Tzd\theta = T(1 - z)d\theta.$$

Summing the moments about o (Fig. 181) gives

$$T + dT = T + \mu p ds.$$

$$\therefore dT = \mu p ds = \mu T(1 - z) d\theta.$$

$$\frac{dT}{T} = \mu(1 - z) d\theta,$$

$$\int_{T_2}^{T_1} \frac{dT}{T} = \mu(1 - z) \int_0^\theta d\theta.$$

$$\therefore \log_e \frac{T_1}{T_2} = \mu(1 - z)\theta$$

and common $\log \frac{T_1}{T_2} = .4343\mu(1 - z)\theta.$

The following equations are now established:

$$T_1 - T_2 = P, \quad \dots \dots \dots (1)$$

$$T_1 + T_2 = 2T_3, \quad \dots \dots \dots (2)$$

$$\log \frac{T_1}{T_2} = .4343\mu(1 - z)\theta. \quad \dots \dots \dots (3)$$

When the belt speed is under 2000 feet per minute the value of z is so small that it may be neglected, and equation (3) becomes

$$\log \frac{T_1}{T_2} = .4343\mu\theta.$$

The right-hand members of (1) and (3) can usually be determined; hence the value of T (the maximum stress in the belt) may be found, and proper proportions may be given to the belt. If W foot-pounds per minute are to be transmitted, and the velocity of the rim of the pulley transmitting this power in feet per minute equals V , then the force P equals the work divided by the velocity, or $P = \frac{W}{V}$. The value of α is found from the diameters of the pulleys and their distance between centers,

and may usually be estimated accurately enough. The value of μ , the coefficient of friction, varies with the kind of belting, the material and character of surface of the pulley, and with the rate of slip of the belt on the pulley. Experiments made at the laboratory of the Massachusetts Institute of Technology, under the direction of Professor Lanza, indicate that for leather belting running on turned cast-iron pulleys, the rate of slip for efficient driving is about 3 to 4 feet per minute; and also that the coefficient of friction corresponding to this rate of slip is about 0.27. The value 0.3 may be used. If this value of μ be used, the slip will be kept within the above limits, if the belt be put on with a proper initial tension, $= T_3 = \frac{T_1 + T_2}{2}$, and the driving of the belt so designed will be satisfactory.

The weight of leather belting on the average per cubic inch $= w = 0.035$ lb.

The value of the allowable tension varies with the quality of the belt, the nature of the splice, and other items. $t = 300$ lbs. per square inch is a good safe value for ordinary conditions. This is about equivalent to 70 lbs. per inch of width of single belt. The following table of values of z has been computed with these values of w and t . V is the velocity of the belt in feet per minute, and v is the velocity in feet per second.

TABLE XIX.—VALUES OF z .

$V \dots$	1800	2400	3000	3600	4200	4800	5400	6000	6600	7200	7800
$v \dots$	30	40	50	60	70	80	90	100	110	120	130
$z \dots$.039	.070	.118	.157	.214	.279	.252	.435	.526	.626	.735

It becomes evident that $1 - z$ decreases rapidly as the velocity of the belt increases. In fact, unless a greater value of t than 300 lbs. per square inch is used a leather belt weighing 0.035 lb. per cubic inch will cause z to have a value of unity at about

9000 feet per minute. This would make the term $1 - z$ reduce to zero. In other words the belt can transmit no power at this speed because the centrifugal force is so great that no pressure exists between the belt and the face of the pulley and hence there is no friction.

168. Problem.—A single-acting pump has a plunger 8 inches = 0.667 foot in diameter, whose stroke has a constant length of 10 inches = 0.833 foot. The number of strokes per minute is 50. The plunger is actuated by a crank, and the crank-shaft is connected by spur-gears to a pulley-shaft, the ratio of gears being such that the pulley-shaft runs 300 revolutions per minute. The pulley which receives the power from the line-shaft is 18 inches in diameter. The pressure in the delivery-pipe is 100 lbs. per square inch. The line-shaft runs 150 revolutions per minute, and its axis is at a distance of 12 feet from the axis of the pulley-shaft.

Since the line-shaft runs half as fast as the pulley-shaft, the diameter of the pulley on the line-shaft must be twice as great as that on the pulley-shaft, or 36 inches. The work to be done per minute, neglecting the friction in the machine, is equal to the number of pounds of water pumped per minute multiplied by the head in feet against which it is pumped. The number of cubic feet of water per minute, neglecting "slip," equals the displacement of the plunger in cubic feet multiplied by the

$$\text{number of strokes per minute} = \frac{0.667^2 \times \pi}{4} \times 0.833 \times 50 = 14.55,$$

and therefore the number of pounds of water pumped per minute = $14.55 \times 62.4 = 908$. One foot vertical height or "head" of water corresponds to a pressure of 0.433 lb. per square inch, and therefore 100 lbs. per square inch corresponds to a "head" of $100 \div 0.433 = 231$ feet. The work done per minute in pumping the water therefore is equal to $908 \text{ lbs.} \times 231 \text{ feet} = 209,748 \text{ ft.-lbs.}$ The velocity of the rim of the belt-pulley is equal to

$300 \times 1.5 \times \pi = 1414$ feet per minute. Therefore the force $P = T_1 - T_2 = 209,748$ ft.-lbs. per minute $\div 1414$ feet per minute = 148 lbs.

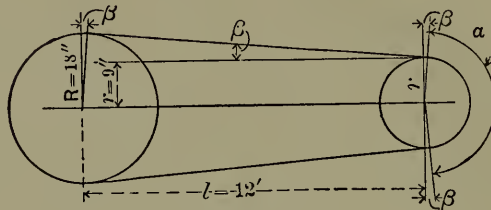

FIG. 182.

To find α (see Fig. 182) $\sin \beta = \frac{R-r}{l} = \frac{9''}{144''} = 0.0625$.

Therefore $\beta = 3^\circ 35'$; $\alpha = 180^\circ - 2\beta = 180^\circ - 7^\circ 10' = 172^\circ 50'$; α

in π measure = $172\frac{5}{6} \times 0.0175 = 3.025 = \theta$.

$$\log \frac{T_1}{T_2} = 0.4343 \times \mu \times \theta = 0.4343 \times 0.3 \times 3.025 = 0.3941.$$

$$\therefore \frac{T_1}{T_2} = 2.48; P = T_1 - T_2 = 148.$$

Combining these equations T_1 is found to be equal to 248 lbs., the maximum stress in the belt.

The cross-sectional area of belt should be equal to $\frac{T_1}{t} = \frac{248}{300} = 0.83$ square inch.

Single-thickness belting varies from 0.2 to 0.25 of an inch in thickness, hence the width called for by our problem would be $\frac{0.83}{0.2} = 4$ inches, say.

169. Problem.—A sixty-horse-power dynamo is to run 1500 revolutions per minute and has a 15-inch pulley on its shaft. Power is supplied by a line-shaft running 150 revolutions per minute. A suitable belt connection is to be designed.

The ratio of angular velocities of dynamo-shaft to line-shaft is 10 to 1; hence the diameter of the pulley on the line-shaft would have to be ten times as great as that of the one on the

dynamo, = 12.5 feet, if the connections were direct. This is inadmissible, and therefore the increase in speed must be obtained by means of an intermediate or *counter shaft*. Suppose that the diameter of the largest pulley that can be used on the counter-shaft = 48 inches. Then the necessary speed of the counter-shaft = $1500 \times \frac{15}{48} = 470$, nearly. The ratio of diameters of the required pulleys for connecting the line-shaft and the counter-shaft = $\frac{470}{150} = 3.13$. Suppose that a 60-inch pulley can be used on the line-shaft, then the diameter of the required pulley for the counter-shaft will = $\frac{60}{3.13} = 19$ inches, nearly. Consider first the belt to connect the dynamo to the counter-shaft. The work = $60 \times 33,000 = 1,980,000$ ft.-lbs. per minute; the rim of the dynamo-pulley moves $\frac{\pi 15}{12} \times 1500 = 5890$ feet per minute.

Therefore $T_1 - T_2 = \frac{1980000}{5890} = 336$ lbs. The axis of the counter-shaft is 10 feet from the axis of the dynamo, and, as before,

$$\sin \beta = \frac{R-r}{l} = \frac{24-7.5}{120} = 0.1375.$$

Therefore $\beta = 7^\circ 54'$.
 $\alpha = 180^\circ - 2\beta = 164^\circ 12'$,
 $\theta = 164^\circ .2 \times 0.0175 = 2.874$.

The nearest value of V , in the table for values of z (p. 232), to 5890 is 6000, and the corresponding value of z is 0.435.

Hence $1 - z = 0.565$.

$$\log \frac{T_1}{T_2} = 0.4343 \times 0.3 \times 0.565 \times 2.874 = 0.2111;$$

$$\therefore \frac{T_1}{T_2} = 1.626.$$

$$T_1 = 1.626T_2.$$

But $T_1 - T_2 = 336$ lbs.

$$\therefore 0.626T_2 = 336 \text{ lbs.}$$

$$\therefore T_2 = 537 \text{ lbs.}$$

$$\therefore T_1 = 873 \text{ lbs.}$$

The cross-sectional area of the belt $= \frac{873}{300} = 2.9$ square inches.

A double belt is about $\frac{3}{8}$ inch thick. Our problem, then, calls for a double belt $\frac{3}{8} \times 2.9 = 8$ inches, say, wide.

170. Variation of Driving Capacity.—From equation (3), p. 231, it follows that the *ratio* of tensions, $\frac{T_1}{T_2}$, when the belt slips at a certain allowable rate (*i.e.*, when μ is constant), depends only upon α . The velocity of the belt also remains constant. This ratio, therefore, is independent of the initial tension, T_3 ; hence “taking up” a belt does not change $\frac{T_1}{T_2}$.

The *difference* of tension, $T_1 - T_2 = P$, is, however, dependent on T_3 . Because p , the normal pressure between belt and pulley, varies directly as T_3 , then, since $dF = \mu p ds = dT$, it follows that dT varies with T_3 , and hence

$$\int dT = T_1 - T_2 = P$$

varies with T_3 . This is equivalent to saying that “taking up” a belt increases its driving capacity.

This result is modified because another variable enters the problem. If T_3 is changed, the amount of slipping changes, and the coefficient of friction varies directly with the amount of slipping. Therefore an increase of T_3 would increase p and decrease μ in the expression $\mu p ds = dT$, and the converse is also true. This is probably of no practical importance.

The value of P may also be increased by increasing either μ , the coefficient of friction, or θ , the arc of contact, since increase of either increases the ratio $\frac{T_1}{T_2}$, and therefore increases $T_1 - T_2 = P$.

Increasing T_3 decreases the life of the belt. It also increases the pressure on the bearings in which the pulley-shaft runs, and therefore increases frictional resistance; hence a greater amount of the energy supplied is converted into heat and lost to any useful purpose. But if T_3 is kept constant, and μ or θ is increased, the driving power is increased without increase of pressure in the bearings, because this pressure $= 2T_3$ remains constant. When possible, therefore, it is preferable to increase P by increase of μ or θ , rather than by increase of T_3 .

Application of belt-dressing may serve sometimes to increase μ .

If, as in Fig. 181, the arrangement is such that the upper side of the belt is the slack side, the "sag" of the belt tends to increase the arc of contact, and therefore to increase $\frac{T_1}{T_2}$. If the lower side is the slack side, the belt sags away from the pulleys and θ and $\frac{T_1}{T_2}$ are decreased.

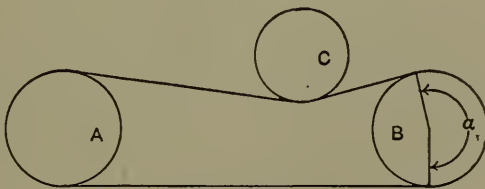

FIG 183.

An idler-pulley, C , may be used, as in Fig. 183. It is pressed against the belt by some means. Its purpose may be to increase P by increasing the tension, $T_3 = \frac{T_1 + T_2}{2}$. In this case friction

in the bearings is increased, and this method should be avoided. Or it may be used on a slack belt to increase the angle of contact, α , the ratio $\frac{T_1}{T_2}$, and therefore P , the driving force. In this case the value of $T_3 = \frac{T_1 + T_2}{2}$, may be made as small a value as is consistent with driving, and hence the journal friction may be small.

Tighteners are sometimes used with slack belts for disengaging gear, the driving-pulley being vertically below the follower.

In the use of any device to increase μ and α , it should be remembered that T_1 is thereby increased, and may become greater than the value for which the belt was designed. This may result in injury to the belt.

In Fig. 184, the smaller pulley, A , is above the larger one, B . A has a smaller arc of contact, and hence the belt would

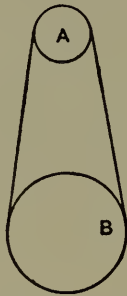

FIG. 184.

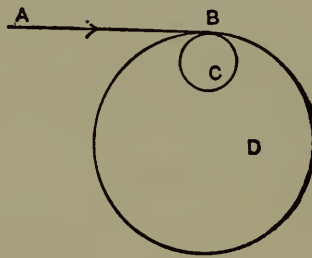

FIG. 185.

slip upon it sooner than upon B . The weight of the belt, however, tends to increase the pressure between the belt and A , and to decrease the pressure between the belt and B . The driving capacity of A is thereby increased, while that of B is diminished; or, in other words, the weight of the belt tends to equalize the inequality of driving power. If the larger pulley had been above, there would have been a tendency for the belt weight to increase the inequality of driving capacity of the

pulleys. The conclusion from this, as to arrangement of pulleys, is obvious.

171. Proper Size of Pulleys.—A belt resists a force which tends to bend it. Work must be done, therefore, in bending a belt around a pulley. The more it is bent the more work is required and the more rapidly the belt is worn out. Suppose *AB*, Fig. 185, to represent a belt which moves from *A* toward *B*. If it runs upon *C* it must be bent more than if it runs upon *D*. The work done in bending the belt is converted into useless heat by the friction between the belt fibers. It is desirable, therefore, to do as little bending as possible. This is one reason why large pulleys in general are more efficient than little ones. The resistance to bending increases with the thickness of the belt, and hence double belts should not be used on small pulleys if it can be avoided.

Double belts may be used on pulleys 12" and over.

Triple " " " " " " 20" " "

Quadruple " " " " " " 30" " "

172. Distance Desirable between Shafts.—In the design of belting care should be taken not to make the distance between the shafts carrying the pulleys too small, especially if there is the possibility of sudden changes of load. Belts have some elasticity, and the total yielding under any given stress is proportional to the length, the area of cross-section being the same. Therefore a long belt becomes a yielding part, or spring, and its yielding may reduce the stress due to a suddenly applied load to a safe value; whereas in the case of a short belt, with other conditions exactly the same, the stress due to much less yielding might be sufficient to rupture or weaken the joint.

173. Rope-drives.—The formulæ which have been derived for belts also apply to rope-drives. For good durability the allowable tension in a rope-drive should be about $200d^2$ lbs. where *d* is the diameter of the rope in inches. Experiments

vary greatly in the value of the coefficient of friction for a well-lubricated rope on a flat-surfaced smooth metal pulley. It may be taken equal to 0.12.* But ropes are not commonly used on flat pulleys; instead of this they run in grooves on the faces of sheave wheels, and substitution must be made for μ in the formula (3), not 0.12 but $0.12 \times \operatorname{cosec} \frac{\text{angle of groove}}{2}$.

The following table gives the values of μ for different angles of grooves.

TABLE XX.

Angle of groove in degrees . . .	30	35	40	45	50	55	60
μ	0.46	0.40	0.35	0.31	0.28	0.26	0.24

Taking the weight of rope per linear inch = $0.0268d^2$ lbs., and the allowable tension = $200d^2$ lbs., and solving for z at various speeds, gives the following results:

TABLE XXI.

V. . .	1000	2000	2500	3000	3500	4000	4500	5000	5500	6000	6500	7000	7500	8000	8500
$1-z$.	0.98	0.94	0.91	0.87	0.83	0.78	0.72	0.65	0.58	0.50	0.41	0.32	0.22	0.11	0.00

V is the velocity of the rope in feet per minute.

For convenience the following table is given showing the corresponding values of angles in degrees and circular measure:

TABLE XXII.

α . .	105	120	135	150	165	180	195	210	240
θ . .	1.83	2.09	2.35	2.62	2.88	3.14	3.43	3.66	4.19

It will be remembered that $\theta = 0.0175\alpha$.

The diameter of the sheave wheel is properly calculated from the point of tangency of the rope to the groove ($A-A$, Fig. 186) and not from the middle of the rope O . The diameter of the sheave wheel should not be too small or the rope will wear out

* "Rope-driving," by J. J. Flather. New York: Wiley & Sons.

very rapidly. The following table gives the minimum values, D being the diameter of the wheel and d that of the rope:

TABLE XXIII.

d	$\frac{3}{4}$ "	1"	$1\frac{1}{4}$ "	$1\frac{1}{2}$ "	$1\frac{3}{4}$ "	2"
D	24	36	48	60	72	84

It is still better to make $D = 4od$.

Two systems of rope-driving are in use, the English and the American. In the former a number of ropes are used side by side. In the latter a single continuous rope is used with a guide and tightener. As long as all the grooves in each sheave are alike, each rope will tend to carry its proportionate share of the load in the English system, provided all the ropes had the same original tension, and have stretched the same amount.

For the American system the grooves in the larger sheave should have a greater angle than those in the smaller sheave or the load will be unequally divided among the various wraps of the rope.*

The tension in each wrap of the rope will be the same, when running, if the friction on each sheave wheel is the same. The friction on each pulley will be the same if the products of the arcs of contact by the respective coefficients are equal.

Let μ = coefficient of larger sheave = $0.12 \operatorname{cosec} \frac{\gamma}{2}$;

γ = angle of groove of larger sheave;

α = arc of contact of larger sheave;



FIG. 186.

* See further Proc. Am. Soc. C. E., Vol. XXIII. Mr. Spencer Miller on Rope-driving.

$$\mu' = \text{coefficient of smaller sheave} = 0.12 \operatorname{cosec} \frac{\gamma'}{2};$$

γ' = angle of groove of smaller sheave;

α' = arc of contact of smaller sheave.

Then $\mu\alpha$ should = $\mu'\alpha'$.

$$\therefore \operatorname{cosec} \frac{\gamma}{2} = \operatorname{cosec} \frac{\gamma'}{2} \times \frac{\alpha'}{\alpha}.$$

The following table gives the proper values for equal adhesion:

TABLE XXIV.—ANGLE OF GROOVE FOR EQUAL ADHESION.

Arc of contact on small pulley = $\frac{\alpha'}{\alpha}$...	0.9	0.8	0.75	0.7	0.65	0.6
Arc of contact on large pulley = $\frac{\alpha}{\alpha'}$...						
Angle of groove in large pulley when groove in small pulley = 35°	40°	44°	47°	51°	55°	60°
Angle of groove in large pulley when groove in small pulley = 40°	45°	50°	54°	58°	64°	70°
Angle of groove in large pulley when groove in small pulley = 45°	50°	55°	60°	66°	72°	80°

The angle of groove on the smaller sheave wheel is generally made 45°. Assuming this an angle of contact of 165°, and an allowable stress = $200d^2$, the following table has been computed for the horse-power transmitted by each wrap of the rope:

TABLE XXV.

Velocity of Rope in Feet per Minute, V.	Diameter of Rope in Inches.						
	$\frac{1}{4}$	$\frac{1}{2}$	1	1 $\frac{1}{4}$	1 $\frac{1}{2}$	1 $\frac{3}{4}$	2
1000	1.24	2.25	3.57	5.59	8.02	10.85	14.20
2000	2.70	3.84	6.84	10.68	15.39	20.93	27.36
2500	3.30	4.71	8.38	13.10	18.86	25.66	33.54
3000	3.83	5.46	9.80	15.39	21.87	29.74	38.88
3500	4.30	6.23	11.09	17.33	24.94	34.03	44.35
4000	4.74	6.83	12.15	18.98	27.33	37.17	48.59
4500	5.01	7.24	12.89	20.15	29.00	39.45	51.57
5000	5.20	7.47	13.29	20.76	29.89	40.65	53.15
5500	5.29	7.60	13.53	21.14	30.43	41.39	54.11
6000	5.08	7.32	13.10	20.36	29.32	39.77	52.12
6500	4.74	6.83	12.13	19.00	27.34	37.21	48.63
7000	4.12	5.93	10.54	16.47	23.72	32.26	42.18
7500	3.25	4.67	8.32	13.00	18.72	25.42	33.23

For durability a few turns of a larger rope are preferable to more turns of a smaller rope.

The most economical speed, taking first cost and relative wear into consideration, is about 4500 feet per minute.

CHAPTER XVI.

FLY-WHEELS.

174. **Theory of Fly-wheel.**—Often in machines there is capacity for uniform effort, but the resistance fluctuates. In other cases a fluctuating effort is applied to overcome a uniform resistance, and yet in both cases a more or less uniform rate of motion must be maintained. When this occurs, as has been explained,* a moving body of considerable weight is interposed between effort and resistance, which, because of its weight, absorbs and stores up energy with increase of velocity when the effort is in excess, and gives it out with decrease of velocity when the resistance is in excess. This moving body is usually a rotating body called a fly-wheel.

To fulfill its office a fly-wheel must have a variation of velocity, because it is by reason of this variation that it is able to store and give out energy. The kinetic energy, E , of a body whose weight is W , moving with a velocity v , is expressed by the equation

$$E = \frac{Wv^2}{2g}.$$

To change E , with W constant, v must vary. The allowable variation of velocity depends upon the work to be accomplished. Thus the variation in an engine running electric lights or spinning-machinery should be very small, probably not greater

* See § 43.

than a half of one per cent, while a pump or a punching-machine may have a much greater variation without interfering with the desired result. If the maximum velocity, v_1 , of the fly-wheel rim and the allowable variation are known, the minimum velocity, v_2 , becomes known; and the energy that can be stored and given out with the allowable change of velocity is equal to the difference of kinetic energy at the two velocities.

$$E = \frac{Wv_1^2}{2g} - \frac{Wv_2^2}{2g} = \frac{W}{2g}(v_1^2 - v_2^2).$$

175. The general method for fly-wheel design is as follows: Find the maximum energy due to excess or deficiency of effort during a cycle of action, $=E$. Use the foot-pound-second system of units. Assume a convenient mean diameter of fly-wheel rim. From this and the given maximum rotative speed of the fly-wheel shaft find v_1 . Solve the above equation for W thus:

$$W = \frac{2gE}{v_1^2 - v_2^2}.$$

Substitute the values of E , v_1 , v_2 , and $g=32.2$ feet per second, whence W becomes known, $=$ weight of fly-wheel rim. The weight of rim only will be considered; the other parts of the wheel, being nearer the axis, have less velocity and less capacity per pound for storing energy. Their effect is to reduce slightly the allowable variation of velocity.*

176. Problem.—In a punching-machine the belt is *capable* of applying a uniform torsional effort to the shaft; but most

* Numerical examples taken from ordinary medium-sized steam-engine fly-wheels show that while the combined weight of arms and hub equals about one third of the total weight of the wheel, the energy stored in them for a given variation of velocity is only about 10 per cent of that stored in the rim for the same variation.

of the time it is only required to drive the moving parts of the machine against frictional resistance. At intervals, however, the punch must be forced through metal which offers shearing resistance to its action. Either the belt or fly-wheel, or the two combined, must be capable of overcoming this resistance. A punch makes 30 strokes per minute, and enters the die $\frac{1}{2}$ inch. It is required to punch $\frac{3}{4}$ -inch holes in steel plates $\frac{1}{2}$ inch thick. The shearing strength of the steel is about 50,000 lbs. per square inch. When the punch just touches the plate the surface which offers shearing resistance to its action equals the surface of the hole which results from the punching, $=\pi dt$, in which d =diameter of hole or punch, t =thickness of plate. The maximum shearing resistance, therefore, equals $\pi \frac{3}{4} \times \frac{1}{2} \times 50,000 = 58,900$ lbs. As the punch advances through the plate the resistance decreases because the surface in shear decreases, and when the punch just passes through the plate the resistance becomes zero. If the change of resistance be assumed uniform (which would probably be approximately true) the mean resistance to punching would equal the maximum resistance + minimum resistance, $\div 2$, $= \frac{58900 + 0}{2} = 29,450$. The radius of the crank which actuates

the punch = 2 in. In Fig. 187 the circle represents the path of the crank-pin center. Its vertical diameter then represents the travel of the punch. If the actuating mechanism be a slotted cross-head, as is usual, it is a case of harmonic motion, and it may be assumed that while the punch travels vertically from A to B , the crank-pin center travels in the semicircle ACB . Let BD and DE each = $\frac{1}{2}$ inch. Then when the punch reaches E it just touches the plate to be punched, which is $\frac{1}{2}$ inch thick, and when it reaches D it has just passed through the plate. Draw the horizontal lines EF and DG and the radial lines OG and OF . Then, while the punch passes through the plate, the crank-pin center moves from F to G , or through an angle (in this case)

of 19° . Therefore the crank-shaft *A*, Fig. 188, and attached gear rotate through 19° during the action of the punch. The ratio of angular velocity of the pinion and the gear = the inverse ratio of pitch diameters = $\frac{60}{12} = 5$. Hence the shaft *B* rotates through an angle = $19^\circ \times 5 = 95^\circ$ during the action of the punch. If there were no fly-wheel the belt would need to be designed to overcome the maximum resistance; *i.e.*, the resistance at the instant when the punch is just beginning to act. This would

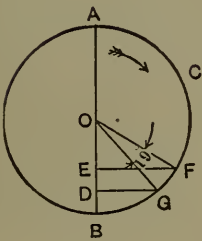

FIG. 187.

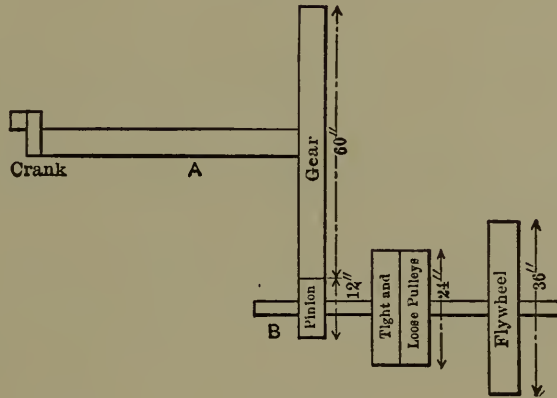

FIG. 188.

give for this case a double belt about 20 inches wide. The need for a fly-wheel is therefore apparent. Assume that the fly-wheel may be conveniently 36 inches mean diameter, and that a single belt 5 inches wide is to be used. The allowable maximum tension is then = $5 \times \text{allowable tension per inch of width of single belting} = 5 \times 70 = 350 \text{ lbs.} = T_1$.

Since the pulley-shaft makes 150 revolutions per minute and the diameter of the pulley is 2 feet, the velocity of the belt = $150 \times 2 \times \pi = 942$ feet per minute. At this slow speed the simple form of the belt formula may be used, *i.e.*, $\log \frac{T_1}{T_2} = 0.4343 \mu \theta$.

Assume an angle of contact of 180° . Then

$$\theta = 3.1416,$$

$$\mu = 0.3,$$

$$\log \frac{T_1}{T_2} = 0.4081;$$

and

$$\therefore \frac{T_1}{T_2} = 2.56.$$

$$T_2 = \frac{350}{2.56} = 136.7 \text{ lbs.}$$

$T_1 - T_2 = 213.3$ lbs. = the driving force at the surface of the pulley.

Assume that the frictional resistance of the machine is equivalent to 25 lbs. applied at the pulley-rim. Then the belt can exert $213.3 - 25 = 188.3$ lbs. = P , to accelerate the fly-wheel or to do the work of punching. Assume variation of velocity = 10 per cent. The work of punching = the mean resistance offered to the punch multiplied by the space through which the punch

acts, $= \frac{58900}{2} \times 0.5'' = 14725$ in.-lbs. = 1225 ft.-lbs. The pulley-shaft moves during the punching through 95° , and the driving tension of the belt, $= P = 188.3$ lbs., does work = $P \times$ space moved through during the punching $= 188.3 \text{ lbs.} \times \pi d \frac{95^\circ}{360} = 188.3$

lbs. $\times \pi \times 2$ ft. $\times \frac{95}{360} = 312$ ft.-lbs. The work left for the fly-

wheel to give out with a reduction of velocity of 10 per cent $= 1225 - 312 = 913$ ft.-lbs. Let v_1 = maximum velocity of fly-

wheel rim; v_2 = minimum velocity of fly-wheel rim; W = weight of the fly-wheel rim. The energy it is capable of giving out,

while its velocity is reduced from v_1 to v_2 , $= \frac{W(v_1^2 - v_2^2)}{2g}$, and

the value of W must be such that this energy given out shall equal 913 ft.-lbs. Hence the following equation may be written:

$$\frac{W(v_1^2 - v_2^2)}{2g} = 913.$$

Therefore
$$W = \frac{913 \times 2 \times g}{v_1^2 - v_2^2}.$$

The punch-shaft makes 30 revolutions per minute and the pulley-shaft $30 \times 5 = 150 = N$ revolutions per minute. Hence v_1 in feet *per second* $\equiv \frac{ND\pi}{60}$, D being fly-wheel diameter in feet = 3 feet.

$$v_1 = \frac{150 \times 3\pi}{60} = 23.56;$$

$$v_2 = 0.90v_1 = 21.2;$$

$$v_1^2 = 555; \quad v_2^2 = 449; \quad v_1^2 - v_2^2 = 106.$$

Hence
$$W = \frac{913 \times 2 \times 32.2}{106} = 555 \text{ lbs.}$$

To proportion the rim: A cubic inch of cast iron weighs 0.26 lb.; hence there must be $\frac{555}{0.26} = 2135$ cu. ins. The cubic contents of the rim = mean diameter $\times \pi \times$ its cross-sectional area $A = 2135$ cu. ins.; hence

$$A = \frac{2135}{36'' \times \pi} = 18.45 \text{ sq. ins.}$$

If the cross-section were made square its side would $= \sqrt{18.45} = 4.3$.

177. Pump Fly-wheel.—The belt for the pump, p. 233, is designed for the *average* work. A fly-wheel is necessary to adapt the varying resistance to the capacity of the belt. The rate of doing work on the return stroke (supposing no resistance due to suction) is only equal to the frictional resistance of the machine. During the working stroke the rate of doing work varies because the velocity of the plunger varies, although the pressure is constant. The rate of doing work is a maximum when the velocity of the plunger is greatest. In Fig. 189, A is the velocity diagram, B is the force diagram, C is the

tangential diagram drawn as indicated on pp. 64-66. The belt, 4 inches wide, is capable of applying a tangential force of 148 lbs. to the 18-inch pulley-rim. The velocity of the pulley-rim $=\pi 1.5 \times 300 = 1414'$. The velocity of the crank-pin axis $=\pi \times 0.833 \times 50 = 130.9'$. Therefore the force of 148 lbs. at the pulley-rim corresponds to a force $=148 \times \frac{1414}{130.9} = 1599$ lbs. applied tangentially at the crank-pin axis. This may be plotted as an ordinate upon the tangential diagram *C*, from the base

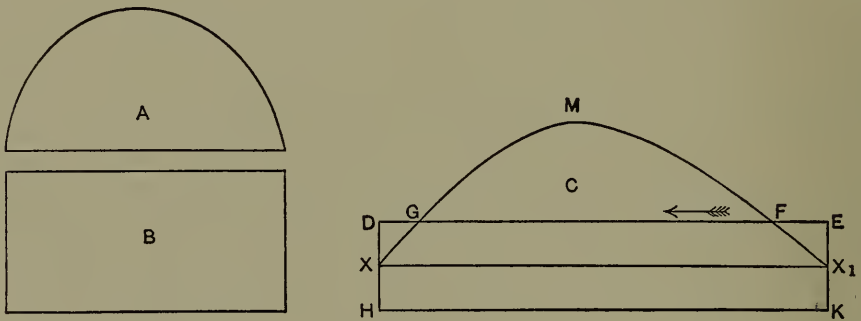

FIG. 189.

line XX_1 , using the same force scale. Through the upper extremity of this ordinate draw the horizontal line DE . The area between DE and XX_1 represents the work the belt is capable of doing during the working stroke. During the return stroke it is capable of doing the same amount of work. But this work must now be absorbed in accelerating the fly-wheel. Suppose the plunger to be moving in the direction shown by the arrow. From E to F the effort is in excess and the fly-wheel is storing energy. From F to G the resistance is in excess and the fly-wheel is giving out energy. The work the fly-wheel must be capable of giving out with the allowable reduction of velocity is that represented by the area under the curve above the line FG . From G to D , and during the entire return stroke, the belt is doing work to accelerate the fly-wheel. This work

becomes stored kinetic energy in the fly-wheel. Obviously the following equation of areas may be written :

$$X_1EF + XGD + XHKKX_1 = GMF.$$

The left-hand member of this equation represents the work done by the belt in accelerating the fly-wheel; the right-hand member represents the work given out by the fly-wheel to help the belt.

The work in foot-pounds represented by the area GMF may be equated with the difference of kinetic energy of the fly-wheel at maximum and minimum velocities. To find the value of this work: One inch of ordinate on the force diagram represents 8520 lbs.; one inch of abscissa represents 0.449 foot. Therefore one square inch of area represents $8520 \text{ lbs.} \times 0.449' = 3825.48 \text{ ft.-lbs.}$ The area $GMF = 0.4 \text{ sq. ins.}$ Therefore the work $= 3825.48 \times 0.4 = 1530 \text{ ft.-lbs.} = E$. The difference of kinetic energy $= \frac{W}{2g}(v_1^2 - v_2^2) = 1530$; W equals the weight of the fly-wheel rim. Hence

$$W = \frac{1530 \times 32.2 \times 2}{v_1^2 - v_2^2}.$$

Assume the mean fly-wheel diameter = 2.5 feet. It will be keyed to the pulley-shaft, and will run 300 revolutions per minute, = 5 revolutions per second. The maximum velocity of fly-wheel rim $= \pi \times 2.5 \times 5 = 39.27 = v_1$. Assume an allowable variation of velocity, = 5 per cent. Then $v_2 = 37.27 \times 0.95 = 37.3$; $v_1^2 = 1542.3$; $v_2^2 = 1391.3$; $v_1^2 - v_2^2 = 151$. Hence

$$W = \frac{1530 \times 32.2 \times 2}{151} = 651 \text{ lbs.}$$

There must be $651 \div 0.26 \text{ cu. in.}$ in the rim, = 2504. The mean circumference $= 30'' \times \pi = 94.2''$. Hence the cross-sectional area

of rim = $2504 \div 94.2 = 26.6$ sq. ins. The rim may be made $4.5'' \times 6''$.

The frictional resistance of the machine is neglected. It might have been estimated and introduced into the problem as a constant resistance.

178. Steam-engine Fly-wheel.—From given data draw the indicator-card as modified by the acceleration of reciprocating parts. See page 63 and Fig. 46. From this and the velocity diagram construct the diagram of tangential driving force, Fig. 47. Measure the area of this diagram and draw the equivalent rectangle on the same base. This rectangle represents the energy of the uniform resistance during one stroke; while the tangential diagram represents the work done by the steam upon the crank-pin. The area of the tangential diagram which extends above the rectangle represents the work to be absorbed by the fly-wheel with the allowable variation of velocity.* Find the value of this in foot-pounds, and equate it to the expression for difference of kinetic energy at maximum and minimum velocity. Solve for W , the weight of fly-wheel.

179. Stresses in Fly-wheel Rims.—Mathematical analyses of the stresses in fly-wheel rims are unsatisfactory. In the first place, in order to get solutions of reasonable simplicity it is customary to make assumptions which are contrary to the actual conditions; and in the second place, no satisfactory data exist concerning the strength of cast iron in such heavy sections as are used in large engine fly-wheels. An examination of the nature of the stresses, however, will indicate the points to be looked out for in design.

Considering a ring of hollow cylindrical form, comparatively

* For compound engines and for varying resistances the diagrams should be constructed for the complete cycle. For full treatment of the problem of fly-wheels for engines driving alternators the reader is referred to the Trans. A. S. M. E., Vol. XXII, p. 955, and Vol. XXIV, p. 98.

thin radially, it can be shown that, when it is rotated about its axis, tension is set up in the ring proportional to the weight of the material used and the square of the linear velocity. This tension is due solely to the action of "centrifugal force" and is termed "centrifugal tension."

Consider the half-ring shown in Fig. 190:

v = the velocity of the rim in feet per second.

c = "centrifugal force" per foot of rim;

R = radius in feet;

A = area of rim in square inches;

P = total tension in rim in pounds;

f_t = unit tensile stress in rim in pounds;

w = weight of material as represented by a piece 1 inch square and 1 foot long;

g = 32.2 feet per second per second;

$2P$ = sum of horizontal components of all the small centrifugal forces cds ;

Each horizontal component = $cds \cos \theta$, which may be written $cR \cos \theta d\theta$, because $ds = R d\theta$.

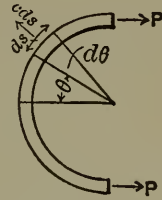

FIG. 190.

$$2P = \int_{\frac{\pi}{2}}^{\frac{\pi}{2}} cR \cos \theta d\theta = 2cR;$$

$$\therefore P = cR.$$

But

$$c = \frac{Mv^2}{R} = \frac{W}{g} \frac{v^2}{R};$$

$$\therefore P = \frac{Wv^2}{g},$$

W being the weight of one linear foot of rim = wA .

Also,

$$P = f_t A;$$

$$\therefore f_t A = \frac{W}{g} v^2 = \frac{w A v^2}{g};$$

$$\therefore f_t = \frac{w v^2}{g}.$$

For cast iron, putting $f_t = 20,000$ lbs. the ultimate strength, and $w = 0.26 \times 12$ lbs., it follows that $v = 454$ feet per second. In other words a cast-iron ring will burst at a speed of 454 feet per second. Furthermore, an examination of the formula shows that for a ring this bursting velocity depends not at all on the size or shape of the cross-section but only on the material used as represented by f_t and w .

This centrifugal tension causes a corresponding elongation of the material and therefore an increase in the radius of the ring. A free ring of whatever cross-section can and does take the new radius and the tension on all sections = f_t pounds per square inch.

With the introduction of rigidly fastened arms a number of new and vital elements enter into the problem. An arm of the same original length as the original radius of the rim when rotated about an axis perpendicular to its inner end will also suffer an elongation due to centrifugal action. The amount of this radial elongation will vary with the form of the arm, but in no practical case will it amount to as much as one third of the radial increase of the ring rotating at the same speed.

To accommodate this difference the arm, if rigidly fastened to hub and rim, will be extended lengthwise by the rim and the rim will be drawn in, out of its regular circular form, by the arm. The relation between the amount the arm is drawn out and the amount the rim is drawn in is governed by the proportions of these parts.

The result is that the rim tends to bow out between the arms and really become akin to a uniformly loaded continuous beam with the dangerous sections midway between the arms and at the points of junction of arms and rim. The fallacy of applying the ring theory solely to the fly-wheel rim becomes evident at once. In a free ring the form of cross-section is immaterial, as the section is subjected only to tension. In the rim with arms the form of cross-section becomes a vital point, as the rim is subjected to flexure as well as tension, and the strength of a member to resist flexure depends directly upon the modulus of the section.

In addition to the foregoing stresses, which are induced under all conditions, even under the extreme supposition that the wheel is rotating at a perfectly uniform rate, there are others when the rim is considered as performing its functions—*i.e.*, in a balance-wheel, absorbing or giving out energy by changes of velocity and, in a band-wheel, transmitting the power.

This may be seen by reference to Fig. 191. *A* shows the relation between rim, arm, and hub when the wheel is at rest or rotating uniformly and not transmitting any power. *B* shows the relation when work is being done. The arm becomes an *encastré* beam and corresponding stresses are induced in it. Furthermore, the bending of the arm tends to shorten it radially, thus drawing in the

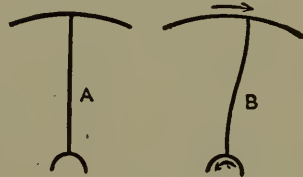

FIG. 191.

outer end, which increases the flexure in the rim. In addition to the foregoing there are stresses in the rim due to the weight of the wheel, shrinkage, etc., which cannot be eliminated.

180. Stresses in Arms of Pulleys or Fly-wheels.—The arms are principally stressed by the bending moment due to variations of velocity of the wheel or to the power transmitted.

Let T = the greatest turning moment transmitted in inch-pounds;

n = number of arms;

f_t = safe unit stress in outer fiber of arm in pounds per square inch;

$\frac{I}{c}$ = modulus of section of arm, dimensions in inches.

Then

$$T = n f_t \frac{I}{c} \text{ may be written and solved for } \frac{I}{c}.$$

Having determined upon the form of cross-section the dimensions can be determined from this value of $\frac{I}{c}$.

If T is unknown the arms can be made as strong as the shaft by equating the twisting strength of the shaft to the bending strength of the arms, thus:

$$f_s \frac{\pi r^3}{2} = n f_t \frac{I}{c}.$$

f_s = allowable shearing stress in outer fiber of shaft, pounds per square inch;

r = radius of shaft in inches;

n , f_t , and $\frac{I}{c}$ as before.

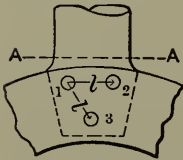

FIG. 192.

Consider junction of arm and hub next. (See Fig. 192.)

The tendency for the arm to fail through flexure on the section $A-A$ may be equated to the tendency for the bolts 2 and 3 to shear off, using 1 as a pivot.

Let A = combined shearing areas of 2 and 3, square inches;

f_s = allowable shearing stress of 2 and 3 in pounds per square inch;

l = distance between centers 1 and 2, and 1 and 3, in inches;

f_t = allowable stress in outer fiber of arm in pounds per square inch;

$\frac{I}{c}$ = modulus of arm section, dimensions in inches.

Then

$$A f_s l = f_t \frac{I}{c},$$

which can be solved for A , the desired area.

If the arm is bolted to the rim a similar method may be employed to make the bolts as strong as the arm.

181. Construction of Fly-wheels.—Since weight is so great a factor in fly-wheels it has been common practice to make them of that material which combines greatest weight with least cost, namely, cast iron. That this is not always safe practice has been conclusively demonstrated by many serious accidents.

Up to 10 feet in diameter the wheels are generally cast in a single piece. Occasionally the hub is divided to relieve the stresses due to cooling. In such cases, supposing the wheel to have six arms, the hub is made in three sections, each having a pair of arms running to the rim. Since the sections are independent, any pair of arms can adjust itself to the conditions of shrinkage without subjecting the other arms to indeterminate stresses. The hub sections are separated from each other by a space of half an inch or less and this is filled with lead or babbitt metal. Then shrink-rings or bolts are used to hold the sections together. Sometimes the hub is only split into two parts.

For reasons connected chiefly with transportation, wheels from 10 to 15 feet in diameter are cast in two halves which are afterwards joined together by flanges and bolts at the rim, and shrink-rings or bolts at the hub.

In still larger and heavier wheels the hub is generally made entirely separate from the arms. The rim is made in as many segments as there are arms. Sometimes the arm is cast with the segment and sometimes the arms and segments are cast separately. The hub is commonly made in the form of a pair of disks having a space between them to receive the arms which are fastened to them by means of accurately fitted through bolts.

Unless the wheel is to be a forced fit on its shaft it is best to have three equally spaced keyways, so that it may be kept accurately centered with the shaft.

In these large wheels the joints of the segments of the rim are usually midway between the arms and steel straps or links such as are shown in Fig. 193 are heated and dropped into recesses previously fitted to receive them. As they



FIG. 193.

cool, their contraction draws the joint together. They should not, however, be subjected to a very great initial tension of this sort. The form shown at *A* is most commonly used. The links are made of high-grade steel and their area is such that their tensile strength equals that of the reduced section of the rim. The areas subjected to shear and compression must also have this strength.

Taking the nature of the stresses into consideration it is clear that the rim should always be as deep radially as possible to resist the flexure action, also that the arms should be near together. Many arms are much better than a few and a disk or web is still better.*

The strongest wheel having arms will be one whose rim is cast in a single piece, while the arms and hubs are cast as a second piece. On the inside of the rim there are lugs between which

* Disk wheels have the further advantage of offering less resistance to the air. This may be a considerable item. See Cassier's Mag., Vol. 23, pp. 577 and 761.

the ends of the arms fit so that there is a space of about one fourth inch all around. (See Fig. 194.) This space may be filled with oakum well driven in. It is clear that the rim in this case acts as a free ring and is subjected solely to centrifugal tension.*

Joints in the rim must always be a source of weakness whether located at the end of the arms or midway between arms.



FIG. 194.

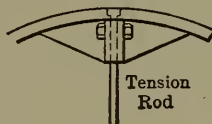

FIG. 195.

If a flanged joint midway between the arms is used, such as is shown in Fig. 195, which is common practice for split band-wheels of medium size, the flanges should be deep radially and well braced by ribs. The bolts should be as close to the rim as possible, and a tension rod should carry the extra stress (due to the weight of the heavy joint and its velocity) to the hub. Experiments made by Prof. C. H. Benjamin † show that the use of such tie-rods increases the strength of the wheel 100 per cent over that of a similar wheel without tie-rods. He also found that jointed rims are only one fourth as strong as solid rims.

Probably as strong a form of cast-iron built-up wheel for heavy duty as any yet designed is one described by Mr. John Fritz, ‡ having a hollow rim and many arms.

But, at the best, cast iron is an uncertain material to use for such tensile and flexure stresses as are induced in a heavy-duty fly-wheel, and it is wiser to make such wheels of structural steel. A built-up wheel having a disk or web of steel plates and a rim of the same material, all joints being carefully "broken" and strongly riveted, is so much better than any built-up cast-

* See Trans. A. S. M. E., Vol. XX, p. 944, and Vol. XXI, p. 322.

† Ibid., Vols. XX and XXIII.

‡ Ibid., Vol. XXI.

iron wheel that the latter are passing out of use. The steel wheels can have at least twice the rim velocity of the cast wheels with greater safety and may therefore be much lighter for the same duty. Their lesser weight makes less pressure on the bearings and consequently less friction loss.*

* For drawings and descriptions of wheels made of forged materials the reader is referred to Vol. XVII, Trans. A. S. M. E., and Power, April 1894, Nov. 1895 Jan. 1896, and Nov. 1897.

CHAPTER XVII.

TOOTHED WHEELS OR GEARS.

182. **Fundamental Theory of Gear Transmission.**—When toothed wheels are used to communicate motion, the motion elements are the tooth surfaces. The contact of these surfaces with each other is line contact. Such pairs of motion elements are called *higher pairs*, to distinguish them from lower pairs, which are in contact throughout their entire surface. Fig. 196 shows the simplest toothed-wheel mechanism. There are three links, a , b , and c , and therefore three centros, ab , bc , and ac . These centros must, as heretofore explained, lie in the same straight line. ac and ab are the centers of the turning pairs connecting c and b to a . It is required to locate bc on the line of centers.

When the gear c is caused to rotate uniformly with a certain angular velocity, *i.e.*, at the rate of m revolutions per minute, it is required to cause the gear b to rotate uniformly at a rate of n revolutions per minute. The angular velocity ratio is therefore constant and $=\frac{m}{n}$. The centro bc is a point on the line of centers which has the same linear velocity whether it is considered as a point in b or c . The linear velocity of this point bc in $b = 2\pi R_1 n$; and the linear velocity of the same point in $c = 2\pi R_2 m$; in which R_1 = radius of bc in b , and R_2 = radius of bc in c . But this linear velocity must be the same in both cases, and hence the above expressions may be equated thus:

$$2\pi R_1 n = 2\pi R_2 m,$$

whence

$$\frac{R_1}{R_2} = \frac{m}{n}.$$

Hence bc is located by dividing the line of centers into parts which are to each other inversely as the angular velocities of the gears.

Thus, let ab and ac , Fig. 197, be the centers of a pair of gears whose angular velocity ratio $= \frac{m}{n}$. Draw the line of centers; divide it into $m+n$ equal parts; m of these from ab toward the right, or n from ac toward the left, will locate bc . Draw circles through bc , with ab and ac as centers. These circles are the centrodes of bc and are called *pitch circles*. It has been already explained that any motion may be reproduced by rolling the centrodes of that motion upon each other without slipping.

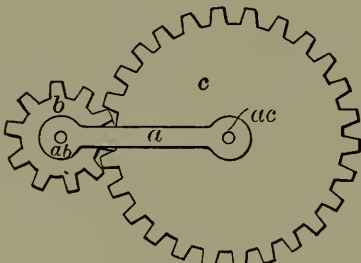

FIG. 196.

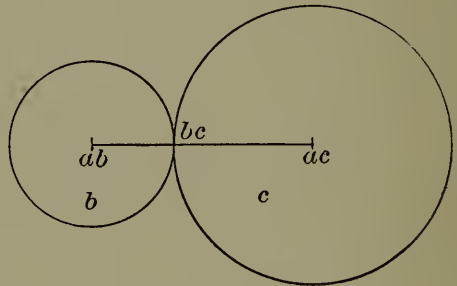

FIG. 197.

Therefore the motion of gears is the same as that which would result from the rolling together of the pitch circles (or cylinders) without slipping. In fact, these pitch cylinders themselves might be, and sometimes are, used for transmitting motion of rotation. Slipping, however, is apt to occur, and hence these "friction-gears" cannot be used if no variation from the given velocity ratio is allowable. Hence teeth are formed on the wheels which engage with each other, to prevent slipping.

183. Definitions.—If the pitch circle be divided into as many equal parts as there are teeth in the gear, the arc included between

two of these divisions is the *circular pitch** of the gear. Circular pitch may also be defined as the distance on the pitch circle occupied by a tooth and a space; or, otherwise, it is the distance on the pitch circle from any point of a tooth to the corresponding point in the next tooth. A fractional tooth is impossible, and therefore the circular pitch must be such a value that the pitch circumference is divisible by it. Let P = circular pitch in inches; let D = pitch diameter in inches; N = number of teeth; then $NP = \pi D$; $N = \frac{\pi D}{P}$; $D = \frac{NP}{\pi}$; $P = \frac{\pi D}{N}$. From these relations any one of the three values, P , D , and N , may be found if the other two are given.

Diametral pitch is the number of teeth per inch of pitch diameter. Thus if p = diametral pitch, $p = \frac{N}{D}$. Multiplying the

two expressions, $P = \frac{\pi D}{N}$ and $p = \frac{N}{D}$, together gives $Pp = \frac{\pi D}{N} \cdot \frac{N}{D} = \pi$.

Or, the product of diametral and circular pitch = π . Circular pitch is usually used for large cast gears, and for mortise-gears (gears with wooden teeth inserted). Diametral pitch is usually used for small cut gears.

In Fig. 198, b , c , and k are pitch points of the teeth; the arc bk is the *circular pitch*; ab is the *face* of the tooth; bm is the *flank* of the tooth; the whole curve abm is the *profile* of the tooth; AD is the *total depth* of the tooth; AC is the *working depth*; AB is the *addendum*; a circle through A is the *addendum circle*. *Clearance* is the excess of total depth over working depth, = CD . *Backlash* is the width of space on the pitch line minus the width of the tooth on the same line. In cast gears whose tooth surfaces are not "tooled," backlash needs to be

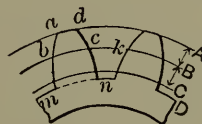

FIG. 198.

* Sometimes called *circumferential pitch*.

allowed, because of unavoidable imperfections in the surfaces. In cut gears, however, it may be reduced almost to zero, and the tooth and space, measured on the pitch circle, may be considered equal.

184. Conditions Governing Forms of Teeth.—Teeth of almost any form may be used, and the *average* velocity will be right. But if the forms are not correct there will be continual variations of velocity ratio between a minimum and maximum value. These variations are in many cases unallowable, and in all cases undesirable. It is necessary therefore to study tooth outlines which shall serve for the transmission of a constant velocity ratio.

The centro of relative motion of the two gears must remain in a constant position in order that the velocity ratio shall be constant. *The essential condition for constant velocity ratio is, therefore, that the position of the centro of relative motion of the gears shall remain unchanged.* If A and B , Fig. 199, are tooth surfaces in contact at a , their only possible relative motion, if they remain in contact, is slipping motion along the tangent CD . The centro of this motion must be in EF , a normal to the tooth surfaces at the point of contact. If these be supposed to be teeth of a pair of gears, b and c , whose required velocity ratio is known, and whose centro, bc , is therefore located, then in order that the motion communicated from one gear to the other through the point of contact, a , shall be the required motion, it is necessary that the centro of the relative motion of the teeth shall coincide with bc .

185. Illustration.—In Fig. 200, let ac and ab be centers of rotation of bodies b and c , and the required velocity ratio is such that the centro of b and c falls at bc . Contact between b and c is at p . The only possible relative motion if these surfaces remain in contact is slipping along CD ; hence the centro of this motion must be on EF , the normal to the tooth surfaces at the point of contact. But it must also be on the same straight line

with ac and ab ; hence it is at bc , and the motion transmitted for the instant, at the point p , is the required motion, because its centro is at bc . But the curves touching at p might be of such form that their common normal at p would intersect the line of centers at some other point, as K , which would then become the centro of the motion of b and c for the instant, and would correspond to the transmission of a different motion. The essential condition to be fulfilled by tooth outlines, in order that a constant velocity ratio may be maintained, may therefore be stated as follows: *The tooth outlines must be such that their normal at the point of contact shall always pass through the centro corresponding to the required velocity ratio.*

FIG. 199.

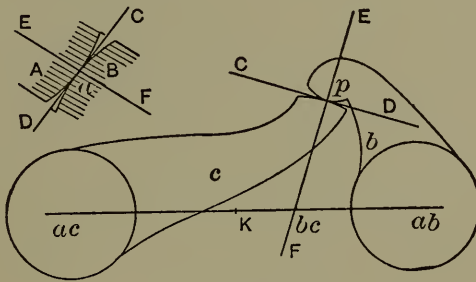

FIG. 200.

186. Given Tooth Outline to Find Form of Engaging Tooth.

—Having given any curve that will serve for a tooth outline in one gear, the corresponding curve may be found in the other gear, which will engage with the given curve and transmit a constant velocity ratio. Let $\frac{m}{n}$ be the given velocity ratio.

$m+n$ = the sum of the radii of the two gears. Draw the line of centers AB , Fig. 201. Let P be the “pitch point,” *i.e.*, the point of contact of the pitch circles or the centro of relative motion of the two gears. To the right from P lay off a distance $PB=m$; from P toward the left lay off $PA=n$. A and B will then be the required centers of the wheels, and the pitch circles

may be drawn through P . Let abc be any given curve on the wheel A . It is required to find the curve in B which shall engage with abc to transmit the constant velocity ratio required. A normal to the point of contact must pass through the centro. If, therefore, any point, as a , be taken in the given curve, and a normal to the curve at that point be drawn, as aa , then when a is the point of contact, α will coincide with P . Also, if $c\gamma$ is a normal to the curve at c , then γ will coincide with P when c is the point of contact between the gears; and since b is in the pitch line, it will itself coincide with P when it is the point of contact.

FIG. 201.

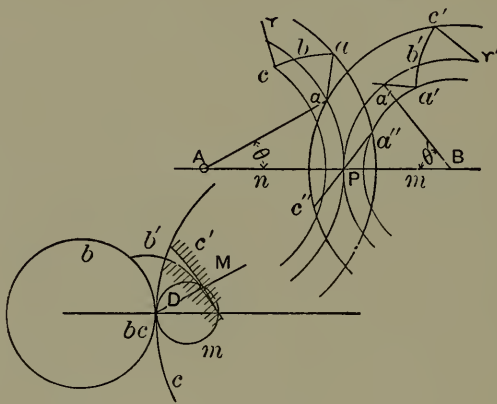

FIG. 202.

Since the two pitch circles must roll upon each other without slipping, it follows that the arc $P\alpha' = \text{arc } P\alpha$, arc $Pb' = \text{arc } Pb$, and arc $P\gamma' = \text{arc } P\gamma$.

Rotate the point α , about A , through the angle θ . At the same time α' rotates backward about B through the angle θ' and α and α' coincide at P . Pa'' represents the rotated position of the normal aa . Rotate Pa'' about B through the angle θ' ; P will coincide with α' and a'' will locate the point a' of the desired tooth outline of gear B . The point b' of the desired outline is readily located by merely laying off arc $Pb' = \text{arc } Pb$.

c' is located by the same method we employed to determine a' . This will give three points in the required curve, and through

these the curve may be drawn. The curve could, of course, be more accurately determined by using more points.

Many curves could be drawn that would not serve for tooth outlines; but, given any curve that will serve, the corresponding curve may be found. There would be, therefore, almost an infinite number of curves that would fulfill the requirements of correct tooth outlines. But in practice two kinds of curves are found so convenient that they are most commonly, though not exclusively, used. They are *cycloidal* and *involute* curves.

187. Cycloidal Tooth Outlines.—It is assumed that the character of cycloidal curves and method of drawing them is understood.

In Fig. 202, let b and c be the pitch circles of a pair of wheels, always in contact at bc . Also, let m be the describing circle in contact with both at the same point. M is the describing point. When one curve rolls upon another, the centro of their relative motion is always their point of contact. For, since the motion of rolling excludes slipping, the two bodies must be stationary, relative to each other, at their point of contact; and bodies that move relative to each other can have but one such stationary point in common—their centro. When, therefore, m rolls in or upon b or c , its centro relatively to either is their point of contact. The point M , therefore, must describe curves whose direction at any point is at right angles to a line joining that point to the point of contact of m with the pitch circles. Suppose the two circles b and c to revolve about their centers, being always in contact at bc ; suppose m to rotate at the same time about its center, the three circles being always in contact at one point and having no slip. The point M will then describe simultaneously a curve, b' , on the plane of b , and a curve, c' , on the plane of c . Since M describes the curves simultaneously, it will always be the point of contact between them in any position. And since the point M moves always at right angles to a line which joins it

to bc , therefore the normal to the tooth surfaces at their point of contact will always pass through bc , and the condition for constant velocity ratio transmission is fulfilled. But these curves are precisely the epicycloid and hypocycloid that would be drawn by the point M in the generating circle, by rolling on the outside of b and inside of c . Obviously, then, the epicycloids and hypocycloids generated in this way, used as tooth profiles, will transmit a constant velocity ratio.

This proof is independent of the size of the generating circle, and its diameter may therefore equal the radius of c . Then the hypocycloids generated by rolling within c would be straight lines coinciding with the radius of c . In this case the flanks of the teeth of c become radial lines, and therefore the teeth are thinner at the base than at the pitch line; for this reason they are weaker than if a smaller generating circle had been used. All tooth curves generated with the same generating circle will work together, the pitch being the same. It is therefore necessary to use the same generating circle for a set of gears which need to *interchange*.*

The describing circle may be made still larger. In the first case the curves described have their convexity in the same direction, *i.e.*, they lie on the same side of a common tangent. When the diameter of the describing circle is made equal to the radius of c , one curve becomes a straight-line tangent to the other curve. As the describing circle becomes still larger, the curves have their convexity in opposite directions. As the circle approximates equality with c , the hypocycloid in c grows shorter, and finally when the describing circle equals c , it becomes a point which is the generating point in c , which is now the generating circle. If this point could be replaced by a pin having no sensible diameter, it would engage with the epicycloid generated by it in the other gear to transmit a constant velocity ratio. But a pin without

* See § 192.

sensible diameter will not serve as a wheel-tooth, and a proper diameter must be assumed, and a new curve laid off to engage with it in the other gear. In Fig. 203, AB is the epicycloid generated by a point in the circumference of the other pitch circle. CD is the new curve drawn tangent to a series of positions of the pin as shown. The pin will engage with this curve,



FIG. 203.

CD , and transmit the constant velocity ratio as required. In Fig. 202, let it be supposed that when the three circles rotate constantly tangent to each other at the pitch point bc , a pencil is fastened at the point M in the circumference of the describing circle. If this pencil be supposed to mark simultaneously upon the planes of b , c , and that of the paper, it will describe upon b an epicycloid, on c a hypocycloid, and on the plane of the paper an arc of the describing circle. Since M is always the point of contact of the cycloidal curves (because it generates them simultaneously), therefore, in cycloidal gear-teeth, *the locus or path of the point of contact is an arc of the describing circle*. The ends of this path in any given case are located by the points at which the addendum circles cut the describing circles.

In the cases already considered, where an epicycloid in one wheel engages with a hypocycloid in the other, the contact of the teeth with each other is all on one side of the line of centers. Thus, in Fig. 202, if the motion be reversed, the curves will be in contact until M returns to bc along the arc $MD-bc$; but after M passes bc contact will cease. If c were the driving-wheel, the point of contact would approach the line of centers; if b were the driving-wheel the point of contact would recede from the line of centers. Experience shows that the latter gives smoother running because of better conditions as regards friction between the tooth surfaces. It would be desirable, therefore, that the wheel with the epicycloidal curves should always be the driver. But it

should be possible to use either wheel as driver to meet the varying conditions in practice.

Another reason why contact should not be all on one side of the line of centers may be explained as follows.

188. Definitions: Pitch-arc, Arc of Action, Line of Pressure.

—The angle through which a gear-wheel turns while one of its teeth is in contact with the corresponding tooth in the other gear is called *the angle of action*. It is found by drawing radial lines from the center of the pitch circle to the two ends of the path of action. The arc of the pitch circle corresponding to the angle of action is called *the arc of action*.

The arc of action must be greater than the "pitch arc" (the arc of the pitch circle that includes one tooth and one space), or else contact will cease between one pair of teeth before it begins between the next pair. Constraint would therefore not be complete, and irregular velocity ratio with noisy action would result.

In Fig. 204, let AB and CD be the pitch circles of a pair of gears and E the describing circle. Let an arc of action be laid off on each of the circles from P , as Pa , Pc , and Pe . Through e , about the center O , draw an addendum circle; *i.e.*, the circle which limits the points of the teeth. Since the circle E is the path of the point of contact, and since the addendum circle limits the points of the teeth, their intersection, e , is the point at which contact ceases, rotation being as indicated by the arrow. If the pitch arc just equals the assumed arc of action, contact will be just beginning at P when it ceases at e ; but if the pitch arc be greater than the arc of action, contact will not begin at P till after it has ceased at e , and there will be an interval when AB will not drive CD . The greater the arc of action the greater the distance of e from P on the circumference of the describing circle. The direction of pressure between the teeth is always a normal to the tooth surface, and this always passes through

the pitch point; therefore the greater the arc of action—*i.e.*, the greater the distance of e from P —the greater the obliquity of the line of pressure. The pressure may be resolved into two components, one at right angles to the line of centers and the other parallel to it. The first is resisted by the teeth of the follower-wheel, and therefore produces pressure with resulting friction. Hence it follows that the greater the arc of action the greater will be the average obliquity of the line of pressure, and therefore the greater the component of the pressure that produces

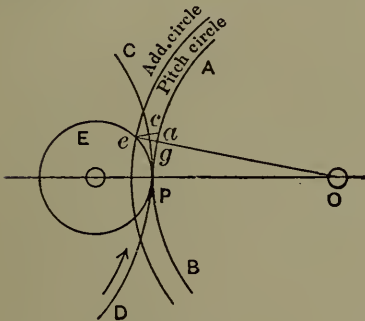

FIG. 204.

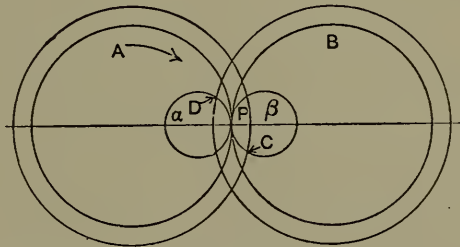

FIG. 205.

wasteful friction. If it can be arranged so that the arc of action shall be partly on each side of the line of centers, the arc of action may be made greater than the pitch arc (usually equal to about $1\frac{1}{2}$ times the pitch arc); then the obliquity of the pressure-line may be kept within reasonable limits, contact between the teeth will be insured in all positions, and either wheel may be the driver. This is accomplished by using two describing circles as in Fig. 205. Suppose the four circles A , B , α , and β to roll constantly tangent at P . α will describe an epicycloid on the plane of B , and a hypocycloid on the plane of A . These curves will engage with each other to drive correctly. β will describe an epicycloid on A , and a hypocycloid on B . These curves will engage, also, to drive correctly. If the epicycloid and hypocycloid in each gear be drawn through the same point on the pitch circle, a double curve tooth outline will be located, and one curve will

engage on one side of the line of centers and the other on the other side. If A drives as indicated by the arrow, contact will begin at D , and the point of contact will follow an arc of α to P , and then an arc of β to C .

189. Involute Tooth Outlines.—If a string is wound around a cylinder and a pencil-point attached to its end, this point will trace an involute on a plane normal to the axis of the cylinder as the string is unwound from the cylinder. Or, if the point be constrained to follow a tangent to the cylinder, and the string be unwound by rotating the cylinder about its axis, the point will trace an involute on a plane that rotates with the cylinder.

Illustration.—Let α , Fig. 206, be a circular piece of wood free to rotate about C ; β is a circular piece of cardboard made fast to α ; AB is a straight-edge held on the circumference of α , having a pencil-point at B . As B moves along the straight-edge to A , α and β rotate about C , and B traces an involute DB upon β , the relative motion of the tracing point and β being just the same as if the string had been simply unwound from α fixed. If the tracing point is caused to return along the straight-edge it will trace the involute BD in a reverse direction.

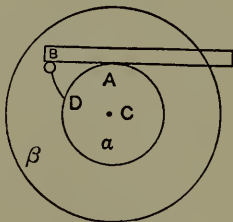

FIG. 206.

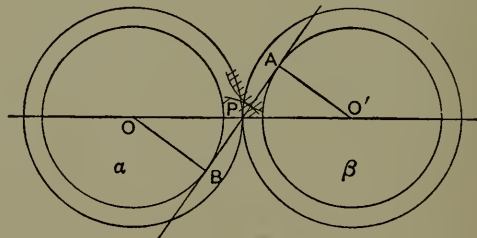

FIG. 207.

The centro of the tracing point is always the point of tangency of the string with the cylinder; therefore the string, or straight-edge, in Fig. 208, is always at right angles to the direction of motion of the tracing point, and hence is always a normal to the involute curve. Let α and β , Fig. 207, be two base cylinders; let AB be a cord wound upon α and β and passing through

the centro P , which corresponds to the required velocity ratio. Let α and β be supposed to rotate so that the cord is wound from β upon α . Then any point in the cord will move from A toward B , and, if it be a tracing-point, will trace an involute of α on the plane of α (extended beyond the base cylinder), and will also trace an involute of β upon the plane of β . These two involutes will serve for tooth profiles for the transmission of the required constant velocity ratio, because AB is the constant normal to both curves at their point of contact, and it passes through P , the centro corresponding to the required velocity ratio. Hence the necessary condition is fulfilled. The pitch circles will have OP and $O'P$ as their respective radii.

Since a point in the line AB describes the two involute curves simultaneously, the point of contact of the curves is always in the line AB . And hence AB is the path of the point of contact. In any given case the two ends of the path lie at the intersections of the addendum circles with AB . The *angle of action* and the *arc of action* are found by drawing radial lines from the center of the pitch circle to the ends of the path of contact.

One of the advantages of involute curves for tooth profiles is that a change in distance between centers of the gears does not interfere with the transmission of a constant velocity ratio. This may be proved as follows: In Fig. 207, from similar triangles $\frac{OB}{O'A} = \frac{OP}{O'P}$; that is, the ratio of the radii of the base circles (*i.e.*, sections of the base cylinders) is equal to the ratio of the radii of the pitch circles. This ratio equals the inverse ratio of angular velocities of the gears. Suppose now that O and O' be moved nearer together; the pitch circles will be smaller, but the ratio of their radii must be equal to the unchanged ratio of the radii of the base circles, and therefore the velocity ratio remains unchanged. Also the involute curves, since they are generated from the same base cylinders, will be the same as before, and

therefore, with the same tooth outlines, the same constant velocity ratio will be transmitted as before.

190. Racks.—A rack is a wheel whose pitch radius is infinite; its pitch circle, therefore, becomes a straight line, and is tangent to the pitch circle of the wheel, or pinion,* with which the rack engages. The line of centers is a normal to the pitch line of the rack, through the center of the pitch circle of the pinion. The pitch of the rack is determined by laying off the circular pitch of the engaging wheel on the pitch line of the rack. The curves of the cycloidal rack-teeth, like those of wheels of finite radius, may be generated by a point in the circumference of a circle which rolls on the pitch circle. Since, however, the pitch circle is now a straight line, the tooth curves will be cycloids, both for flanks and faces. In Fig. 208, AB is the pitch circle of the pinion and CD is the pitch line of the rack; a and b are describing circles. Suppose, as before, that all move without slipping and are constantly tangent at P . A point in the circumference of a will then

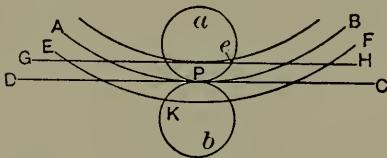

FIG. 208.

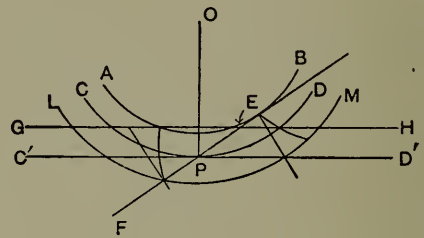

FIG. 209.

describe simultaneously a cycloid on CD , and a hypocycloid within AB . These will be correct tooth outlines. Also, a point in the circumference of b will describe a cycloid on CD and an epicycloid on AB . These will be correct tooth outlines. To find the path of the point of contact, draw the addendum circle EF of the pinion, and the addendum line GH of the rack. When the pinion turns clockwise and drives the rack, contact will begin

* Pinion is a word to denote a gear having a low number of teeth, or the smaller one of a pair of engaging gears.

at e and follow arcs of the describing circles through P to K . It is obvious that a rack cannot be used where rotation is continuous in one direction, but only where motion is reversed.

Involute curves may also be used for the outlines of rack teeth. Let CD and $C'D'$, Fig. 209, be the pitch lines. When it is required to generate involute curves for tooth outlines, for a pair of gears of finite radius, a line is drawn through the pitch point at a given angle to the line of centers (usually 75°); this line is the path of the point which generates two involutes simultaneously, and therefore the path of the point of contact between the tooth curves. It is also the common tangent to the two base circles, which may now be drawn and used for the describing of the involutes. To apply this to the case of a rack and pinion, draw EF , Fig. 209, making the desired angle with the line of centers, OP . The base circles must be drawn tangent to this line; AB will therefore be the base circle for the pinion. But the base circle in the rack has an infinite radius, and a circle of infinite radius drawn tangent to EF would be a straight line coincident with EF . Therefore EF is the base line of the rack. But an involute to a base circle of infinite radius is a straight line normal to the circumference—in this case a straight line perpendicular to EF . Therefore the tooth profiles of a rack in the involute system will always be straight lines perpendicular to the path of the describing point, and passing through the pitch points. If, in Fig. 209, the pinion move clockwise and drive the rack, the contact will begin at E , the intersection of the addendum line of the rack GH , and the path of the point of contact EF , and will follow the line EF through P to the point where EF cuts the addendum circle LM of the pinion.

191. Annular Gears.—Both centers of a pair of gears may be on the same side of the pitch point. This arrangement corresponds to what is known as an annular gear and pinion. Thus,

in Fig. 210, AB and CD are the pitch circles, and their centers are both above the pitch point P . Teeth may be constructed to transmit rotation between AB and CD . AB will be an ordinary

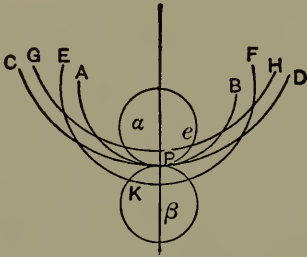

FIG. 210.

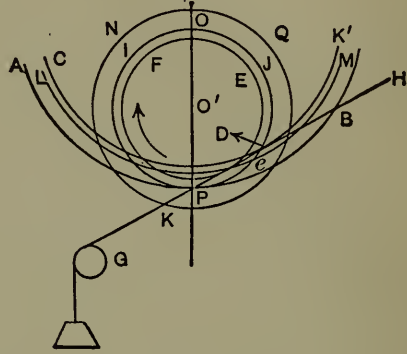

FIG. 211.

spur pinion, but it is obvious that CD becomes a ring of metal with teeth on the inside, *i.e.*, it is an annular gear. In this case α and β may be describing circles for cycloidal teeth, and a point in the circumference of α will describe hypocycloids simultaneously on the planes of AB and CD ; and a point in the circumference of β will describe epicycloids simultaneously on the planes of AB and CD . These will engage to transmit a constant velocity ratio. Obviously the space inside of an annular gear corresponds to a spur-gear of the same pitch and pitch diameter, with tooth curves drawn with the same describing circle. Let EF and GH , Fig. 212, be the addendum circles. If the pinion move clockwise driving the annular gear, the path of the point of contact will be from e along the circumference of α to P , and from P along the circumference of β to K .

The construction of involute teeth for an annular gear and pinion involves exactly the same principles as in the case of a pair of spur-gears. The only difference of detail is that the describing point is in the tangent to the base circles *produced* instead of being between the points of tangency. Let O and O' ,

Fig. 211, be the centers, and AB and IJ the pitch circles of an annular gear and pinion. Through P , the point of tangency of the pitch circles, draw the path of the point of contact at the given angle with the line of centers. With O and O' as centers draw tangent circles to this line. These will be the involute base circles. Let the tangent be replaced by a cord, made fast, say, at K' , winding on the circumference of the base circle CK' , to D , and then around the base circle FE in the direction of the arrow, and passing over the pulley G , which holds it in line with PB . If rotation be supposed to occur with the two pitch circles always tangent at P without slipping, any point in the cord beyond P toward G will describe an involute on the plane IJ , and another on the plane of AB . These will be the correct involute tooth profiles required. Draw NQ and LM , the addendum circles. Then if the pinion move clockwise, driving the annular gear, the point of contact starts from e and moves along the line GH through P to K .

When a pair of spur-gears mesh with each other, the direction of rotation is reversed. But an annular gear and pinion meshing together rotate in the same direction.

192. Interchangeable Sets of Gears.—In practice it is desirable to have “interchangeable sets” of gears; *i.e.*, sets in which any gear will “mesh” correctly with any other, from the smallest pinion to the rack, and in which, except for limiting conditions of size, any spur-gear will mesh with any annular gear. Interchangeable sets may be made in either the cycloidal or involute system. A necessary condition in any set is that the *pitch shall be constant*, because the thickness of tooth on the pitch line must always equal the width of the space (less backlash). If this condition is unfulfilled they cannot engage, whatever the form of the tooth outlines.

The second condition for an interchangeable set in the cycloidal system is that *the size of the describing circle shall be*

constant. If the diameter of the describing circle equal the radius of the smallest pinion's pitch circle, the flanks of this pinion's teeth will be radial lines, and the tooth will therefore be thinner at the base than at the pitch line. As the gears increase in size with this constant size of describing circle, the teeth grow thicker at the base; hence the weakest teeth are those of the smallest pinion.

It is found unadvisable to make a pinion with less than twelve teeth. If the radius of a fifteen-tooth pinion be selected for the diameter of the describing circle, the flanks which bound a space in a twelve-tooth pinion will be very nearly parallel, and may therefore be cut with a milling-cutter. This would not be possible if the describing circle were made larger, causing the space to become wider at the bottom than at the pitch circle. Therefore the maximum describing circle for milled gears is one whose diameter equals the pitch radius of a fifteen-tooth pinion and it is the one usually selected. Each change in the number of teeth with constant pitch causes a change in the size of the pitch circle. Hence the form of the tooth outline, generated by a describing circle of constant diameter, also changes. For any pitch, therefore, a separate cutter would be required corresponding to every number of teeth, to insure absolute accuracy. Practically, however, this is not necessary. The change in the form of tooth outline is much greater in a small gear, for any increase in the number of teeth, than in a large one. It is found that twenty-four cutters will cut all possible gears of the same pitch with sufficient practical accuracy. The range of these cutters is indicated in the following table, taken from Brown and Sharpe's "Treatise on Gearing."

These same principles of interchangeable sets of gears with cycloidal tooth outlines apply not only to small milled gears as above, but also to large cast gears with tooled or untooled tooth surfaces.

TABLE XXVI.

Cutter A cuts 12 teeth	Cutter M cuts 27 to 29 teeth
" B " 13 "	" N " 30 " 33 "
" C " 14 "	" O " 34 " 37 "
" D " 15 "	" P " 38 " 42 "
" E " 16 "	" Q " 43 " 49 "
" F " 17 "	" R " 50 " 59 "
" G " 18 "	" S " 60 " 74 "
" H " 19 "	" T " 75 " 99 "
" I " 20 "	" U " 100 " 149 "
" J " 21 to 22 teeth	" V " 150 " 249 "
" K " 23 " 24 "	" W " 250 " rack
" L " 24 " 26 "	" X " rack

193. Interchangeable Involute Gears.—In the involute system the second condition of interchangeability is that the *angle between the common tangent to the base circles and the line of centers shall be constant*. This may be shown as follows: Draw the line of centers, AB , Fig. 212. Through P , the assumed pitch point, draw CD , and let it be the constant common tangent to all base

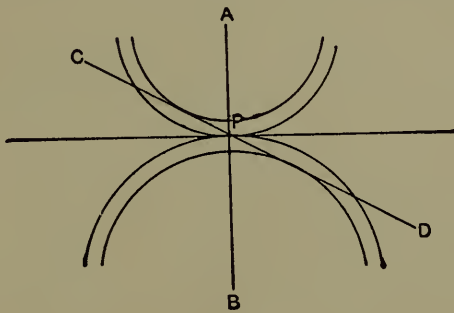

FIG. 212.

circles from which involute tooth curves are to be drawn. Draw any pair of pitch circles tangent at P , with their centers in the line AB . About these centers draw circles tangent to CD ; these are base circles, and CD may represent a cord that winds from one upon the other. A point in this cord will generate simultaneously involutes that will engage for the transmission of a constant velocity ratio. But this is true of *any* pair of circles that have their centers in AB , and are tangent to CD . Therefore,

if the pitch is constant, any pair of gears that have the base circles tangent to the line *CD* will mesh together properly. As in the cycloidal gears, the involute tooth curves vary with a variation in the number of teeth, and, for absolute theoretical accuracy, there would be required for each pitch as many cutters as there are gears with different numbers of teeth. The variation is least at the pitch line, and increases with the distance from it. The involute teeth are usually used for the finer pitches and the cycloidal teeth for the coarser pitches; and since the amount that the tooth surface extends beyond the pitch line increases with the pitch, it follows that the variation in form of tooth curves is greater in the coarse pitch cycloidal gears than in the fine pitch involute gears. For this reason, with involute gears, it is only necessary to use *eight* cutters for each pitch. The range is shown in the following table, which is also taken from Brown and Sharpe's "Treatise on Gearing":

TABLE XXVII.

No.	1	will cut wheels from	135	teeth to racks
"	2	"	"	"
"	3	"	"	"
"	4	"	"	"
"	5	"	"	"
"	6	"	"	"
"	7	"	"	"
"	8	"	"	"

55	"	"	134 inclusive
35	"	"	54 "
26	"	"	34 "
21	"	"	25 "
17	"	"	20 "
14	"	"	16 "
12	"	"	13 "

194. Laying Out Gear-teeth. — *Exact and Approximate Methods.*—There is ordinarily no reason why an exact method for laying out cycloidal or involute curves for tooth outlines should not be used, either for large gears or gear patterns, or in making drawings. It is required to lay out a cycloidal gear. The pitch, and diameters of pitch circle and describing circle are given.

Draw the pitch circle on the drawing-paper, using a fine line. On a flat piece of tracing-cloth or thin, transparent celluloid draw a circle the size of the generating circle. Use a fine, clear line.

Place it over the drawn pitch circle so that it is tangent to the latter at P as shown in Fig. 213. AB is an arc of the pitch circle.

Insert a needle point at P , and using it as a pivot swing the tracing-cloth in the direction of the arrow a very short distance, so that the generating circle cuts the pitch circle at a new point Q , as shown exaggeratedly in Fig. 214. Q should be taken very close

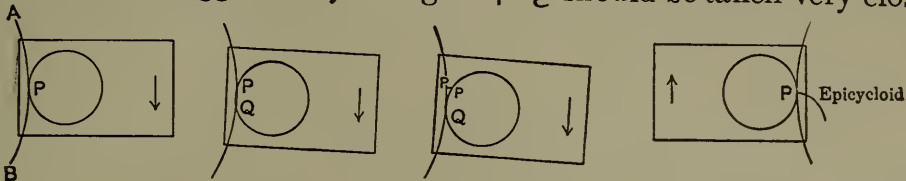

FIG. 213.

FIG. 214.

FIG. 215.

FIG. 216.

to P . Insert a needle point at Q , remove the one at P , and swing the cloth, about Q as a pivot, in the direction of the arrow until the two circles are tangent at Q . (See Fig. 215.) The point P of the tracing-cloth now lies off the pitch circle a short distance. With a needle point prick its present position through to the drawing-paper. Now with Q as a pivot rotate the tracing-cloth until the two circles intersect at a point R slightly beyond Q . Insert needle at R and remove the one at Q . Swing tracing-cloth about R until R becomes the point of tangency of the two circles and then prick the *new* position of P through to the drawing-paper. Taking points very near together and repeating the operation gives a close approximation to true rolling of the generating circle on the pitch circle and therefore the path of the point P as marked on the drawing-paper by pricked points is an epicycloid and may be used for the face of the tooth.

Next place the tracing-cloth on the inside of the pitch circle, as shown in Fig. 216, with the generating circle tangent to the pitch circle at the original point P . Using the method just described to prevent slipping, roll the generating circle, in the direction of the arrow, on the pitch circle and the path traced by P as marked by pricked points on the drawing-paper will be a hypocycloid for the flank of the tooth.

The compound curve aPb , Fig. 217, has now been traced, which forms the basis of the completed tooth outline.

AB is an arc of the pitch circle whose center is at O . With O as center, swing in the addendum circle CD and the full depth circle EF , according to the proportions given in § 195. With a radius equal to $\frac{1}{4}$ of the circular pitch draw the fillet cd tangent to EF and aPb . The completed tooth profile is the curve $cdPe$.

Cut a wooden template to fit the tooth curve, and make it fast to a wooden arm free to rotate about O , making the edge of the template coincide with $cdPe$. It may now be swung successively to the other pitch points, and the tooth outline may be drawn by the template edge. This gives one side of all of the teeth. The arm may now be turned over and the other sides of the teeth may be drawn similarly.

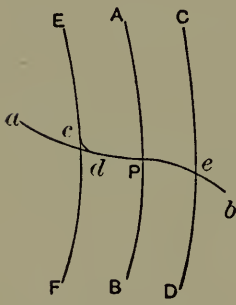

FIG. 217.

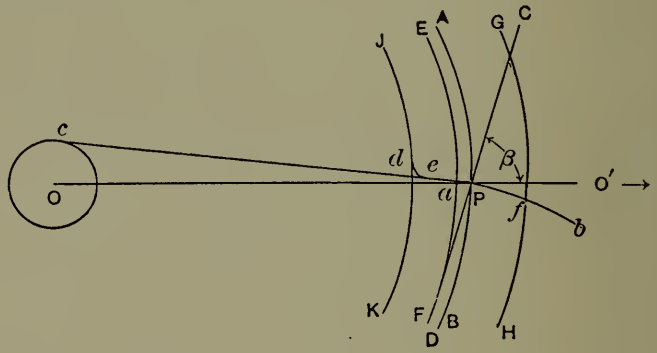

FIG. 218.

It is required to lay out exact involute teeth. The pitch, pitch-circle diameter, and angle of the common tangent are given.—Draw the pitch circle AB , Fig. 218, and the line of centers OO' . Through the pitch point P draw CD , the common tangent to the base circles, making the angle β with the line of centers. Draw the base circle EF about O tangent to CD .

On a piece of flat tracing-cloth draw a fine, clear, straight line and lay the tracing-cloth over the drawing so that this line coincides with CD . Take a needle point and insert it at the point

of tangency Q . With another needle, mark the point P on the tracing-cloth. Now, employing a pair of needle points to prevent slipping, roll the traced line on the base circle EF , pricking the path, aPb , of the point P of the tracing-cloth through to the drawing-paper. This path is the involute of the base circle and is the basis of the involute tooth outline. To complete the latter proceed as follows: Draw the addendum circle GH and the full-depth circle JK . In general JK will lie inside of the base circle EF and it will be necessary to extend the tooth outline inward beyond a . About O swing a circle whose diameter equals one half the circular pitch and draw ac tangent to it. With a radius equal to $\frac{1}{4}$ of the circular pitch swing in the fillet de tangent to JK and ac . $deaPj$ is the completed outline. If the gear has 20 teeth or less ac should be made a radial line. If EF lies inside of JK we draw the fillet tangent to JK and aP .*

195. Gear Proportions.—The following formulas and table are given to assist in the practical proportioning of gears:

Let D =pitch diameter;

D_1 =outside diameter;

D_2 =diameter of a circle through the bottom of spaces;

P =circular pitch =space on the pitch circle occupied by a tooth and a space;

p =diametral pitch =number of teeth per inch of pitch-circle diameter;

N =number of teeth;

t =thickness of tooth on pitch line;

a =addendum;

* Approximate tooth outlines may be drawn by the use of instruments, such as the Willis odontograph, which locates the centers of approximate circular arcs; the templet odontograph, invented by Prof. S. W. Robinson; or by some geometrical or tabular method for the location of the centers of approximate circular arcs. For descriptions, see "Elements of Mechanism," Willis; "Kinematics," McCord; "Teeth of Gears," George B. Grant; "Treatise on Gearing," published by Brown and Sharpe.

c = clearance;

d = working depth of spaces;

d_1 = full depth of spaces.

Then

$$D_1 = \frac{N+2}{p}; \quad D_2 = D - 2(a+c);$$

$$N = \frac{D\pi}{P}; \quad P = \frac{D\pi}{N}; \quad D = \frac{PN}{\pi}; \quad N = Dp;$$

$$p = \frac{N}{D}; \quad D = \frac{N}{p}; \quad Pp = \pi;$$

$$p = \frac{\pi}{P}; \quad P = \frac{\pi}{p}; \quad t = \frac{P}{2} = \frac{\pi}{2p}, \text{ no backlash};$$

$$c = \frac{t}{10} = \frac{P}{20} = \frac{\pi}{p20}; \quad d = 2a; \quad d_1 = 2a + c; \quad a = \frac{1}{p} \text{ inches.}$$

The following dimensions are given as a guide; they may be varied as conditions of design require: Width of face = about $3P$; thickness of rim = $1.25t$; thickness of arms = $1.25t$, no taper. The rim may be reinforced by a rib, as shown in Fig. 219. Diameter of hub = $2 \times$ diameter of shaft. Length of hub = width of face + $\frac{1}{2}$ " ; width of arm at junction with hub = $\frac{1}{6}$ circumference of the hub for six arms. Make arms taper about $\frac{1}{4}$ " per foot on each side.

TABLE XXVIII.

Diametral Pitch. p	Circular Pitch. P	Thickness of Tooth on the Pitch Line. t	Diametral Pitch. p	Circular Pitch. P	Thickness of Tooth on the Pitch Line. t
$\frac{1}{2}$	6.283	3.141	$3\frac{1}{2}$.897	.449
$\frac{3}{4}$	4.189	2.094	4	.785	.393
1	3.141	1.571	5	.628	.314
$1\frac{1}{4}$	2.513	1.256	6	.523	.262
$1\frac{1}{2}$	2.094	1.047	7	.449	.224
$1\frac{3}{4}$	1.795	.897	8	.393	.196
2	1.571	.785	9	.349	.174
$2\frac{1}{4}$	1.396	.698	10	.314	.157
$2\frac{1}{2}$	1.256	.628	12	.262	.131
$2\frac{3}{4}$	1.142	.571	14	.224	.112
3	1.047	.523			

196. Strength of Gear-teeth.—The maximum work transmitted by a shaft per unit time may usually be accurately estimated; and, if the rate of rotation is known, the torsional moment may be found. Let O , Fig. 220, represent the axis of a shaft perpendicular to the paper. Let A = maximum work to be transmitted per minute; let N = revolutions per minute; let Fr = torsional moment. Then F is the force factor of the work transmitted, and $2\pi rN$ is the space factor of the work transmitted. Hence

$$2F\pi rN = A, \quad \text{and} \quad Fr = \text{torsional moment} = \frac{A}{2\pi N}.$$

If the work is to be transmitted to another shaft by means of a spur-gear whose radius is r_1 , then for equilibrium $F_1 r_1 = Fr$, and $F_1 = \frac{Fr}{r_1}$. F_1 is the force at the pitch surface of the gear whose radius is r_1 , *i.e.*, it is the force to be sustained by the gear-teeth. Hence, in general, *the force sustained by the teeth of a gear equals the torsional moment divided by the pitch radius of the gear.*

When the maximum force to be sustained is known the teeth may be given proper proportions. The dimensions upon which the tooth depends for strength are: Thickness of tooth = t , width of face of gear = b , and depth of space between teeth = l . These all become known when the pitch is known, because t is fixed for any pitch, and l and b have values dictated by good practice. The value of b may be varied through quite a range to meet the requirements of any special case.

In the design the tooth will be treated as a cantilever with a load applied at its end. It is assumed that one tooth sustains the entire load; *i.e.*, that there is contact only between one pair of teeth. This would be nearly true for gears with low numbers of teeth; but in high-numbered gears the force would be distributed over several pairs, and hence they would have an excess of strength. It is also assumed that the load is uniformly distributed across the face of the tooth. This is a safe assumption if the width of

face, b , does not exceed three times the circular pitch, *i.e.*, $3P$, and if the gears are well aligned and rigidly supported. All teeth of the same pitch have not the same form, as was explained in the discussion of interchangeable gears, and therefore they vary in strength. The fewer teeth the thinner they will be at their base and consequently the weaker they will be when acting as cantilevers.

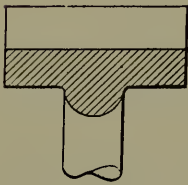

FIG. 219.

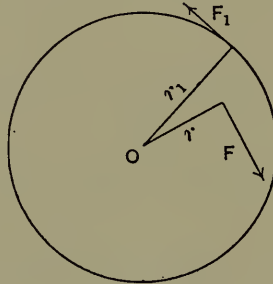

FIG. 220.

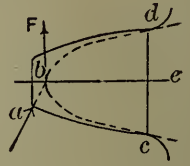

FIG. 221.

Mr. Wilfred Lewis* has drawn a number of figures on a large scale to represent very accurately the teeth cut by complete sets of cutters of the 15° involute, the 20° involute, and the cycloidal systems. In the latter he used a rolling circle having a diameter equal to the radius of the 12-tooth pinion. The proportions of the teeth used in his investigation are slightly different from those given above which correspond to the Brown and Sharpe system, but no serious errors will result from applying the formulas derived by him. His reasoning was as follows (see Fig. 221):

The greatest stress in the tooth occurs when the load is applied at the end of the tooth as indicated by the arrow at a , its direction of action being normal to the profile at a . The component of this force, which is effective to produce rotation of the gear, equals F and is called the working force.

This load is applied at b and induces a transverse stress in the tooth. To determine where the tooth is weakest advantage is taken of the fact that any parabola in the axis be and tangent to

* Proc. Phila. Eng. Club, 1893, and Amer. Mach., May 4 and June 22, 1893.

bF incloses a beam of uniform strength. Of all the parabolas that may thus be drawn one only will be tangent to the tooth form (as shown by the dotted line in the figure) and the weakest section of the tooth will be that through the points of tangency c and d . Having determined the weakest section in each case, Mr. Lewis developed the following general formulæ from the data so obtained:

For 15° involute and the cycloidal system, using a rolling circle whose diameter equals the radius of the 12-tooth pinion,

$$F = jPb \left(0.124 - \frac{0.684}{N} \right).$$

For the 20° involute system

$$F = jPb \left(0.154 - \frac{0.912}{N} \right).*$$

F = working force in pounds;

j = safe allowable unit stress in pounds per square inch;

P = circular pitch in inches;

b = width of face of gear in inches;

N = number of teeth in the gear.

Experimental data fixing the value of j for different materials and velocities is lacking. The following table is recommended by Mr. Lewis:

TABLE XXIX.

Velocity of pitch line in feet per minute ..	100 or less	200	300	600	900	1200	1800	2400
j for cast iron.	8000	6000	4800	4000	3000	2400	2000	1700
j for steel.	20000	15000	12000	10000	7500	6000	5000	4300

* For the cycloidal system, using a rolling circle whose diameter equals the radius of the 15-tooth pinion,

$$F = jPb \left(0.106 - \frac{0.678}{N} \right).$$

(Trans. A. S. M. E., Vol. 18, p. 776.)

In these formulæ, for a given gear the whole right side of the equation becomes known and the allowable value of F is readily determined. It is more difficult to apply the formulæ where the force to be transmitted is given. In such a case the value of P is determined by trial.

197. Problem.—Design a pair of 15° involute gears to transmit 6 H.P. The distance between centers is 10 inches and the velocity ratio of the shafts is to be $\frac{2}{3}$. The pinion shaft makes 150 revolutions per minute.

The distance between centers being 10 inches and the velocity ratio $\frac{2}{3}$, the radii will be to each other as 3:2 and their sum = 10 inches, hence the radius of the pinion will be 4 inches, while that of the gear will be 6 inches. If both gears are of the same material the teeth of the smaller will be the weaker. Computations will therefore be made for the pinion because the gear will be stronger and, consequently, safe. The pitch diameter of the pinion = 8 inches, its velocity = $150 \times \pi \times \frac{8}{12} = 314.2$ feet per minute.

$$6 \text{ H.P.} = 6 \times 33,000 = 198,000 \text{ ft.-lbs. per minute;}$$

$$F = \frac{198000}{314.2} = 632 \text{ lbs.}$$

Assuming cast-iron gears at 314.2 feet per minute, f may be taken = 4800 lbs. The maximum value of $b = 3P$, but for first trial let $b = 1$ inch. For the 15° involute system, then,

$$632 = 4800 \times P \times 1 \left(0.124 - \frac{0.684}{N} \right).$$

But
$$N = \frac{D}{P} = \frac{25.13}{P}.$$

Substituting this, transposing, and clearing of fractions,

$$P^2 - 4.56P + 4.84 = 0,$$

from which $P - 2.28 = \pm 0.6$.

Choosing the smaller value,

$$P = 1.68 \text{ inches.}$$

A pitch of 1.68 inches with a width of face of 1 inch is bad proportion.

For our second trial let $b = 2$ inches,

$$632 = 4800 \times 2 \times P \left(0.124 - \frac{0.684P}{25.13} \right).$$

Solving this gives

$$P = 0.62 \text{ inch.}$$

This corresponds practically to a diametral pitch of 5, giving $5 \times 8 = 40$ teeth for the pinion. The engaging gear will have $5 \times 12 = 60$ teeth.

When the solution of the quadratic equation leads to an imaginary quantity it will be necessary to increase b . If the greatest allowable value of b still leaves the imaginary, then the value f must be increased either by using a stronger material or by cutting down the factor of safety.

Another way of solving the problem would have been to assume b in terms of P , thus $b = KP$ (K being less than 3), thus giving

$$F = fKP^2 \left(0.124 - \frac{0.684P}{D} \right).$$

In this substitute trial values for P until one is found which satisfies the equation.

198. Non-circular Wheels.—Only circular centrodes or pitch curves correspond to a constant velocity ratio; and by making the pitch curves of proper form, almost any variation in the velocity

ratio may be produced. Thus a gear whose pitch curve is an ellipse, rotating about one of its foci, may engage with another elliptical gear, and if the driver has a constant angular velocity the follower will have a continually varying angular velocity. If the follower is rigidly attached to the crank of a slider-crank chain, the slider will have a quick return motion. This is sometimes used for shapers and slotting-machines. When more than one fluctuation of velocity per revolution is required, it may be obtained by means of "lobed gears"; *i.e.*, gears in which the curvature of the pitch curve is several times reversed. If a describing circle be rolled on these non-circular pitch curves, the tooth outlines will vary in different parts; hence in order to cut such gears, many cutters would be required for each gear. Practically this would be too expensive; and when such gears are used the pattern is accurately made, and the cast gears are used without "tooling" the tooth surfaces.

199. Bevel-gears.—All transverse sections of spur-gears are the same, and their axes intersect at infinity. Spur-gears serve to transmit motion between parallel shafts. It is necessary also to transmit motion between shafts whose axes intersect. In this case the pitch cylinders become pitch cones; the teeth are formed

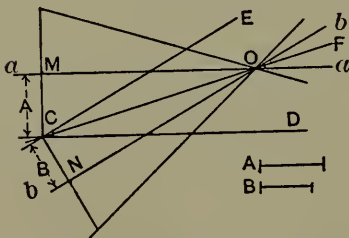

FIG. 222.

upon these conical surfaces, the resulting gears being called bevel-gears. To illustrate, let a and b , Fig. 222, be the axes between which the motion is to be transmitted with a given velocity ratio. This ratio is equal to the ratio of the length of the line A to that of B .

Draw a line CD parallel to a , at a distance from it equal to the length of the line A . Also draw the line CE parallel to b , at a distance from it equal to the length of the line B . Join the point of intersection of these lines to the point O , the intersection of the given axes. This locates the line OF , which

is the line of contact of two pitch cones which will roll together to transmit the required velocity ratio. For $\frac{MC}{NC} = \frac{A}{B}$, and if it be supposed that there are frusta of cones so thin that they may be considered cylinders, their radii being equal to MC and NC , it follows that they would roll together, if slipping be prevented, to transmit the required velocity ratio. But all pairs of radii of these pitch cones have the same ratio, $= \frac{MC}{NC}$, and therefore any pair of frusta of the pitch cones may be used to roll together for the transmission of the required velocity ratio. To insure this result, slipping must be prevented, and hence teeth are formed upon the selected frusta of the pitch cones. The theoretical determination of these may be explained as follows:

200. 1st. Cycloidal Teeth.—If a cone, A (Fig. 223), be rolled upon another cone, B , their apexes coinciding, an element bc of the cone A will generate a conical surface, and a spherical sec-

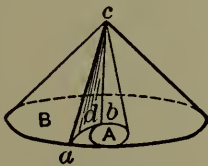

FIG. 223.

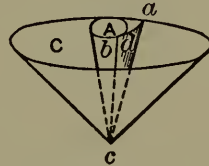

FIG. 224.

tion of this surface, adb , is called a spherical epicycloid. Also if a cone, A (Fig. 224), roll on the inside of another cone, C , their apexes coinciding, an element bc of A will generate a conical surface, a spherical section of which, bda , is called a spherical hypocycloid. If now the three cones, B , C , and A , with apexes coinciding, roll together, always tangent to each other on one line, as the cylinders were in the case of spur-gears, there will be two conical surfaces generated by an element of A : one upon the cone B and another upon the cone C . These may be used for tooth surfaces to transmit the required constant velocity

ratio. Because, since the line of contact of the cones is the axo* of the relative motion of the cones, it follows that a plane normal to the motion of the describing element of the generating cone at any time will pass through this axo. And also, since the describing element is always the line of contact between the generated tooth surfaces, the normal plane to the line of contact of the tooth surfaces always passes through the axo, and the condition of rotation with a constant velocity ratio is fulfilled.

201. 2d. Involute Teeth.—If two pitch cones are in contact along an element, a plane may be passed through this element making an angle (say 75°) with the plane of the axes of the cones. Tangent to this plane there may be two cones whose axes coincide with the axes of the pitch cones. If a plane is supposed to wind off from one base cone upon the other, the line of tangency of the plane with one cone will leave the cone and advance in the plane toward the other cone, and will generate simultaneously upon the pitch cones' conical surfaces, and spherical sections of these surfaces will be spherical involutes. These surfaces may be used for tooth surfaces, and will transmit the required constant velocity ratio, because the tangent plane is the constant normal to the tooth surfaces at their line of contact, and this plane passes through the axo of the pitch cones.

202. Determination of Bevel-gear Teeth.—To determine the tooth surfaces with perfect accuracy, it would be necessary to draw the required curves on a spherical surface, and then to join all points of these curves to the point of intersection of the axes of the pitch cones. Practically this would be impossible, and an approximate method is used.

If the frusta of pitch cones be given, *B* and *C*, Fig. 225, then points in the base circles of the cones, as *L*, *M*, and *K*, will move always in the surface of a sphere whose projection is the circle

* An axo is an instantaneous axis, of which a centro is a projection.

LAKM. Properly, the tooth curves should be laid out on the surface of this sphere and joined to the center of the sphere to generate the tooth surfaces. Draw cones *LGM* and *MHK* tangent to the sphere on circles represented in projection by lines *LM* and *MK*. They are called the "back cones." If now tooth curves are drawn on these cones, with the base circle of the cones as pitch circles, they will approximate the tooth curves that should be drawn on the spherical surface. But a cone may be cut along one of its elements and rolled out, or developed, upon a plane. Let *MDH* be a part of the cone *MHK*, developed, and let *MNG* be a part of the cone *MGL*, developed.

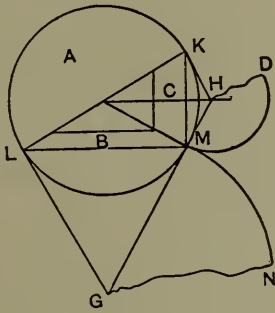

FIG. 225.



FIG. 226.

The circular arcs *MD* and *MN* may be used just as pitch circles are in the case of spur-gears, and the teeth may be laid out in exactly the same way, the curves being either cycloidal or involute, as required. Then the developed cones may be wrapped back and the curves drawn may serve as directrices for the tooth surfaces, all of whose elements converge to the center of the sphere of motion.

203. Cutting Bevel-gear Teeth.—The teeth of spur-gears may be cut by means of milling-cutters, because all transverse sections are alike, but with bevel-gears the conditions are different. The tooth surfaces are conical surfaces, and therefore the curvature varies constantly from one end of the tooth to the other. Also the

thickness of the tooth and the width of space vary constantly from one end to the other. But the curvature and thickness of a milling-cutter cannot vary, and therefore a milling-cutter cannot cut an accurate bevel-gear. Small bevel-gears are, however, cut with milling-cutters with sufficient accuracy for practical purposes. The cutter is made as thick as the narrowest part of the space between the teeth, and its curvature is made that of the middle of the tooth. Two cuts are made for each space. Let Fig. 226 represent a section of the cutter. For the first cut it is set relatively to the gear blank, so that the pitch point a of the cutter travels toward the apex of the pitch cone, and for the second cut so that the pitch point b travels toward the apex of the pitch cone. This method gives an approximation to the required form. Gears cut in this manner usually need to be filed slightly before they work satisfactorily. Bevel-gears with absolutely correct tooth surfaces may be made by planing. Suppose a planer in which the tool point travels always in some line through the apex of the pitch cone. Then suppose that as it is slowly fed down the tooth surface, it is guided along the required tooth curve by means of a templet. From what has preceded it will be clear that the tooth so formed will be correct. Planers embodying these principles have been designed and constructed by Mr. Corliss of Providence, and Mr. Gleason of Rochester, with the most satisfactory results.

204. Design of Bevel-gears.—Given energy to be transmitted, rate of rotation of one shaft, velocity ratio, and angle between axes; to design a pair of bevel-gears. Locate the intersection of axes, O , Fig. 227. Draw the axes OA and OB , making the required angle with each other. Locate OC , the line of tangency of the pitch cones, by the method given on p. 290. Any pair of frusta of the pitch cones may be selected upon which to form the teeth. Special conditions of the problem usually dictate this selection approximately. Suppose that the inner limit of the

teeth may be conveniently at D . Then make DP , the width of face, $=DO \div 2$. Or, if P is located by some limiting condition, lay off $PD = PO \div 3$. In either case the limits of the teeth are defined tentatively. Now from the energy and the number of revolutions of one shaft (either shaft may be used) the moment of torsion may be found. The mean force at the pitch surface $=$ this torsional moment \div the mean radius of the gear; *i.e.*, the radius of the point M , Fig. 227, midway between P and D . The pitch corresponding to this force may be found.

In order to compute it consider the teeth of the pinion (*i.e.*, the smaller gear), as they will be the weaker. Having found the force, F , which is to be transmitted we determine the pitch required to carry F by a spur-gear, whose pitch radius $=MN$ and whose width of face, b , equals PD . (The radius MN is used to govern the shape of the tooth and not MR , because the teeth are laid off on the developed back cones and not on the pitch circles, as has been explained. The circle whose radius is MN is sometimes called the *formative* circle in order to distinguish it from the pitch circle.)

The pitch of such a spur-gear would be the mean pitch of the bevel-gears. But the pitch of bevel-gears is measured at the large end, and diametral pitch varies inversely as the distance from O . In this case the distances of M and P from O are to each other as 5 is to 6. Hence the value of diametral pitch found $\times \frac{5}{6} =$ the diametral pitch of the bevel-gear. If this value does not correspond with any of the usual values of diametral pitch, the next smaller value may be used. This would result in a slightly increased factor of safety. If the diametral pitch thus found, multiplied by the diameter $2PQ$, does not give an integer for the number of teeth, the point P may be moved outward along the line OC , until the number of teeth becomes an integer. This also would result in slight increase of the factor of safety. The point P is thus finally located, the corrected width of face $=PO \div 3$,

and the pitch is known. The drawing of the gears may be completed as follows: Draw AB perpendicular to PO . With A and B as centers, draw the arcs PE and PF . Use these as pitch arcs, and draw the outlines of two or three teeth upon them, with

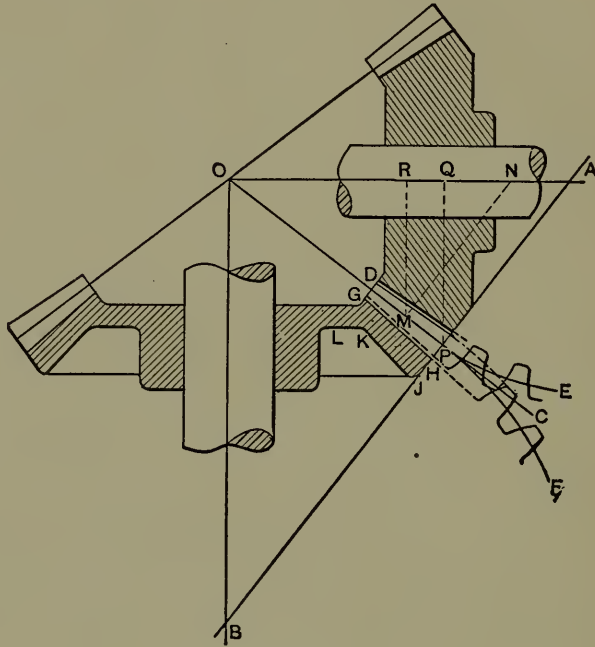

FIG. 227.

cycloidal or involute curves as required. These will serve to show the form of tooth outlines. From P each way along the line AB lay off the addendum and the clearance. From the four points thus located draw lines toward O terminating in the line DG . The tops of teeth and the bottoms of spaces are thus defined. Lay off upon AB below the bottoms of the spaces a space HJ about equal to $\frac{5}{4}$ the thickness of the tooth on the pitch circle. This gives a ring of metal to support the teeth. From J draw JK toward O . The web L should have about the same thickness as the ring has at K . Join this web to a properly proportioned hub as shown. The plan and elevation of each gear may now be drawn by the ordinary methods of projection. Use large fillets.

205. Skew Bevel-gears.—Spur-gears serve to communicate motion between parallel axes, and bevel-gears between axes that intersect. But it is sometimes necessary to communicate motion between axes that are neither parallel nor intersecting. If the parallel axes are turned out of parallelism, or if intersecting axes are moved into different planes, so that they no longer intersect, the pitch surfaces become hyperbolic paraboloids in contact with each other along a straight line, which is the generatrix of the pitch surfaces. These hyperbolic paraboloids rolled upon each other, circumferential slipping being prevented, will transmit motion with a constant velocity ratio. There is, however, necessarily a slipping of the elements of the surfaces upon each other parallel to themselves. Teeth may be formed on these pitch surfaces, and they may be used for the transmission of motion between shafts that are not parallel nor in the same plane. Such gears are called “Skew Bevel-gears.” The difficulties of construction and the additional friction due to slipping along the elements make them undesirable in practice, and there is seldom a place where they cannot be replaced by some other form of connection.

A very complete discussion of the subject of Skew Bevel-gears may be found in Professor McCord’s “Kinematics.”

206 Spiral Gearing.—If line contact is not essential there is much wider range of choice of gears to connect shafts which are neither parallel nor intersecting. *A* and *B*, Fig. 228, are axes of rotation in different planes, both planes being parallel to the paper. Let *EF* and *GH* be cylinders on these axes, tangent to each other at the point *S*. Any line may now be drawn through *S* either between *A* and *B* or coinciding with either of them. This line, say *DS*, may be taken as the common tangent to helical or screw lines drawn on the cylinders *EF* and *GH*, or helical surfaces may be formed on both cylinders, *DS* being

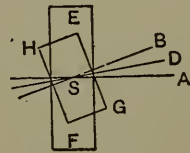

FIG. 228.

their common tangent at S . *Spiral gears* are thus produced. Each one is a portion of a many-threaded screw. The contact in these gears is point contact; in practice the point of contact becomes a very limited area.*

207. Worm-gearing.—When the angle between the shafts is made equal to 90° , and one gear has only one, two, three, or four threads, it becomes a special case of spiral gearing known as *Worm-gearing*. In this special case the gear with a few threads is called the *worm*, while the other gear, which is still a many-threaded screw, is called the *worm-wheel*. If a section of a worm and worm-wheel be made on a plane passing through the axis of the worm, and normal to the axis of the worm-wheel, the form of the teeth will be the same as that of a rack and pinion; in fact the worm, if moved parallel to its axis, would transmit rotary motion to the worm-wheel. From the consideration of racks and pinions it follows that if the involute system is used, the sides of the worm-teeth will be straight lines. This simplifies the cutting of the worm, because a tool may be used capable of being sharpened without special methods. If the worm-wheel were only a thin plate the teeth would be formed like those of a spur-gear of the same pitch and diameter. But since the worm-wheel must have greater thickness, and since all other sections parallel to that through the axis of the worm, as CD and AB , Fig. 229, show a different form and location of tooth, it is necessary to make the teeth of the worm-wheel different from those of a spur-gear, if there is to be contact between the worm and worm-wheel anywhere except in the plane EF , Fig. 229. This would seem to involve great difficulty, but it is accomplished in practice as follows: A duplicate of the worm is made of tool steel, and “flutes” are cut in it parallel to the axis, thus making it into a cutter,

* See further “Worm and Spiral Gearing,” by F. A. Halsey. Van Nostrand Science Series.

which is tempered. It is then mounted in a frame in the same relation to the worm-wheel that the worm is to have when they are finished and in position for working. The distance between centers, however, is somewhat greater, and is capable of being gradually reduced. Both are then rotated with the required velocity ratio by means of gearing properly arranged, and the cutter or "hob" is fed against the worm-wheel till the distance between centers becomes the required value. The teeth of the

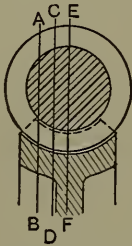

FIG. 229

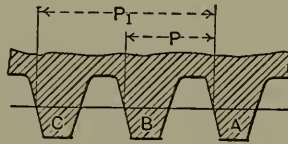

FIG. 230.

worm-wheel are "roughed out" before they are "hobbed." By the above method the worm is made to cut its own worm-wheel.*

Fig. 230 represents the half section of a worm. If it is a single worm the thread *A*, in going once around, comes to *B*; twice around to *C*, and so on. If it is a double worm the thread *A*, in going once around, comes to *C*, while there is an intermediate thread, *B*. It follows that if the single worm turns through one revolution it will push *one* tooth of the worm-wheel with which it engages past the line of centers; while the double worm will push *two* teeth of the worm-wheel past the line of centers. The single worm, therefore, must make as many revolutions as there are teeth in the worm-wheel, in order to cause one revolution of the worm-wheel; while for the same result the double worm only needs to make half as many revolutions

* This subject is fully treated in Unwin's "Elements of Machine Design," and in Brown and Sharpe's "Treatise on Gearing."

The ratio of the angular velocity of a single worm to that of the worm-wheel with which it engages is $=\frac{n}{1}$, in which n equals the number of teeth in the worm-wheel. For the double worm this ratio is $\frac{n}{2}$.

Worm-gearing is particularly well adapted for use where it is necessary to get a high velocity ratio in limited space.

The pitch of a worm is measured parallel to the axis of rotation. The pitch of a single worm is P , Fig. 230. It is equal to the circular pitch of the worm-wheel. The pitch of a double worm is $P_1 = 2P = 2 \times$ circular pitch of the worm-wheel.

208. Design of Worm-gears.—All spiral gears are forms of screw transmission and the formulæ for efficiency, etc., developed under c , p. 133, in the chapter on Screws, apply to them directly.

Three points are to be carefully considered in the design of worms and wheels:

1. *Speed of rubbing.* This is the velocity in feet per minute of a point on the pitch line of the worm. The best efficiencies are obtained when this is about 200 feet per minute. When it exceeds 300 feet there is increasing danger of cutting, and the pressure on the teeth must be correspondingly reduced. At high speeds (say 1000 feet) only very light pressure can be sustained without abrasion.

2. *Pressure on teeth.* This depends on the speed and on the angle of helix.

3. *Angle of helix.* From the formula for screw efficiency we have seen that this should be made as great as convenient provided it does not exceed 45° . Practical conditions make it impossible to use the highest values, but 20° gives very excellent results. It should never be less than 15° for fair efficiency.

Oil-bath lubrication should be used wherever possible; failing this, a heavy mixture of graphite and oil has been found satis-

factory. The following table based on Professor Stribeck's experiments* applies to a 20° angle of helix and oil-bath lubrication, using a hardened-steel worm and phosphor-bronze wheel.

TABLE XXX.

Rubbing velocity in feet per minute.....	200	300	400	500	600
Allowable pressure for maximum efficiency in pounds.....	3500	2700	1850	1250	1000

This may be taken as a guide. When the angle is greater than 20° the values of the pressure may be slightly increased. When the angle is less than 20° they should be rapidly diminished; thus for 10° use only one half the value given.

209. Problem.—Two shafts about 10 inches apart and at a right angle with one another are to have a velocity ratio of 20 to 1. The worm-shaft makes 300 revolutions per minute.

Since the velocity ratio is 20 to 1, the wheel will have to have 20, 40, or 60 teeth, depending upon whether the worm is single-, double-, or triple-threaded.

If the shafts are 10 inches apart the greatest allowable pitch radius of the wheel will not be far from 8 inches; 50 inches may be taken as a trial pitch circumference of the wheel.

With a single-thread worm this will give a circular pitch of $\frac{50}{20} = 2\frac{1}{2}$ inches. With a double thread the circular pitch would be $\frac{50}{40} = 1\frac{1}{4}$ inches.

In any case the rise of the pitch helix of the worm will be $2\frac{1}{2}$ inches for one revolution.

This value must always be such that the thread may be cut in an ordinary lathe.

* Zeitschrift d. Vereins deutscher Ingenieure.

If it is required that the helix angle, α , be 20° , then the pitch circumference of the worm must be such that

$$\text{tang. } 20^\circ = \frac{2.5}{\text{pitch circumference of worm}};$$

$$\therefore \text{pitch circumference of worm} = \frac{2.5}{0.364} = 6.87 \text{ inches.}$$

$$\text{Pitch diameter of worm} = \frac{6.87}{\pi} = 2.2 \text{ inches.}$$

$$\text{Pitch diameter of wheel} = \frac{50}{\pi} = 15.88 \text{ inches.}$$

$$\text{Actual distance between shafts} = \frac{15.88 + 2.2}{2} = 9.04 \text{ inches.}$$

The question now arises whether 2.2 inches is a great enough pitch diameter for the worm. If the thread is single the pitch = 2.5 inches and the corresponding dedendum = 0.92 inch.

Twice this dedendum = 1.84 inches, which subtracted from 2.2 inches would only leave a central solid core of 0.36 inch diameter for the worm. It is obvious without computation that this would not sustain the torsional moment. If the double thread were used the central core would have a diameter of 1.28 inches.

For each revolution of the worm the length of the path of the point of contact or the distance *rubbed* over equals the helix length on the pitch line. This is the hypotenuse of a right-angle triangle whose base = 6.87 inches and whose altitude = 2.5 inches, or 7.3 inches.

At 300 revolutions per minute the distance rubbed through in feet per minute = $300 \times \frac{7.3}{12} = 182$ feet. At 182 feet the allowable pressure, W , between the teeth may equal 3500 lbs., assuming bath lubrication, a steel worm, and a bronze wheel. This is the

pressure applied at the circumference of the worm-wheel in the direction of the axis of the worm. The total work done on the worm-wheel in foot-pounds per minute will equal W multiplied by the pitch velocity of the wheel in feet per minute.

This wheel makes $\frac{3600}{240} = 15$ revolutions per minute and its pitch circumference = $\frac{50}{12}$ feet, hence its pitch velocity = $15 \times \frac{50}{12} = 62.5$ feet per minute.

$$3500 \times 62.5 = 218,750 \text{ ft.-lbs.} = 6.63 \text{ H.P.}$$

This same amount of energy is transmitted through the worm. The twisting moment on the shaft = Fr , where r equals the pitch radius of the worm. F = energy transmitted \div the velocity of the point of application of the force.

$$F = \frac{218750}{300 \times \frac{6.87}{12}} = 1274 \text{ lbs.};$$

$$Fr = 1274 \times 1.1 = 1401 \text{ in.-lbs.}$$

To resist this there is a circular section whose strength is represented by $f_s \frac{\pi r_1^3}{2}$.

$$r_1 = \text{radius of core of worm} = 0.64 \text{ inch};$$

$$f_s = \text{unit stress in outer fiber};$$

$$\therefore f_s = \frac{Fr}{\frac{\pi r_1^3}{2}} = \frac{1401}{.412} = 3400 \text{ lbs.}$$

This is a safe value for steel. Therefore the double-threaded worm will be used and the wheel will have 40 teeth of $1\frac{1}{4}$ inches circular pitch.

For the strength of the worm-wheel teeth Professor Stribeck gives:

$$W = 350Pb \text{ for cast-iron wheels;}$$

$$W = 550Pb \text{ for bronze wheels;}$$

$$W = \text{pressure in direction of worm axis in pounds;}$$

$$P = \text{circular pitch in inches;}$$

$$b = \text{arc } EF, \text{ Fig. 231, in inches.}$$

It will be impossible to make b as great as this would call for in the problem if $W = 3500$ and $P = 1\frac{1}{4}$ inches.

Had the distance between the shafts been fixed at 10 inches the helix angle could not have been assumed but must have been calculated.

The pitch radius of worm would have been

$$10'' - \frac{15.88}{2} = 2.02''.$$

Pitch circumference = 12.69 inches.

$$\text{Tangent of helix angle} = \frac{2.5}{12.69} = 0.1955.$$

$$\therefore \alpha = 11^\circ +.$$

When the worm and worm-wheel are determined, a working drawing may be made as follows: Draw AB , Fig. 231, the axis of the worm-wheel, and locate O , the projection of the axis of the worm, and P , the pitch point. With O as a center draw the pitch, full depth, and addendum circles, G , H , and K ; also the arcs CD and EF , bounding the tops of the teeth and the bottoms of the spaces of the worm-wheel. Make the angle $\beta = 90^\circ$. Below EF lay off a proper thickness of metal to support the teeth and join this by the web LM to the hub N . The tooth outlines in the other sectional view are drawn exactly as for an involute rack and pinion. Full views might be drawn,

but they involve difficulties of construction, and do not give any additional information to the workman.

210. Compound Spur-gear Chains.—Spur-gear chains may be compound, *i.e.*, they may contain links which carry more than two elements. Thus in Fig. 234 the links *a* and *d* each carry three elements. In the latter case the teeth of *d* must be counted as two elements, because by means of them *d* is paired with both *b* and *c*. In the case of the three-link spur-gear chain the wheels *b* and *c* are meshed with each other, and a point in the pitch circle

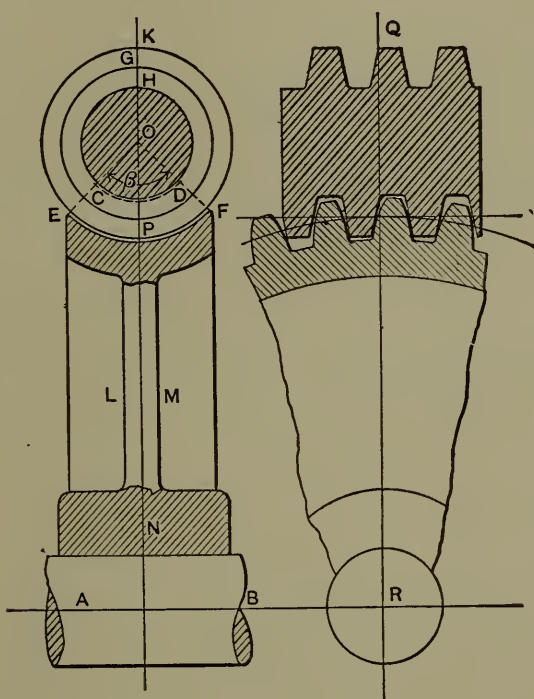

FIG. 231

of *c* moved with the same linear velocity as a point in the pitch circle of *b*, but in the opposite direction. In Fig. 232 points in all the pitch circles have the same linear velocity, since the motion is equivalent to rolling together of the pitch circles without slipping; but *c* and *b* now rotate in the same direction. Hence it is seen that the introduction of the wheel *d* has reversed the direction of rotation, without changing the velocity ratio. The

size of the wheel, d , which is called an "idler," has no effect upon the motion of c and b . It simply receives upon its pitch circle a certain linear velocity from c , and transmits it unchanged to b . Hence the insertion of any number of idlers does not affect the velocity ratio of c to b , but each added idler reverses the direction of the motion. Thus, with an odd number of idlers, c and b will rotate in the same direction; and with an even number of idlers c and b will rotate in opposite directions.

If parallel lines be drawn through the centers of rotation of a pair of gears, and if distances be laid off from the centers on these lines inversely proportional to the angular velocities of the gears, then a line joining the points so determined will cut the line of centers in a point which is the centro of the gears. In Fig. 232, since the rotation is in the same direction, the lines have to

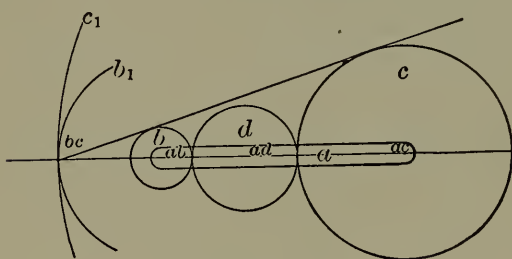

FIG. 232.

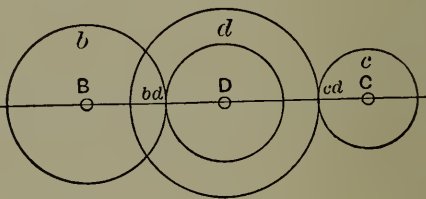

FIG. 233.

be laid off on the same side of the line of centers. The pitch radii are inversely proportional to the angular velocities of the gears, and hence it is only necessary to draw a tangent to the pitch circles of b and c , and the intersection of this line with the line of centers is the centro, bc , of c and b . The centrodes of c and b are c_1 and b_1 , circles through the point bc , about the centers of c and b . Obviously this four-link mechanism may be replaced by a three-link mechanism, in which c_1 is an annular wheel meshing with a pinion b_1 . The four link mechanism is more compact, however, and usually more convenient in practice.

The other principal form of spur-gear chain is shown in

Fig. 233. The wheel d has two sets of teeth of different pitch diameter, one pairing with c and the other with b . The point bd now has a different linear velocity from cd , greater or less in proportion to the ratio of the radii of those points. The angular velocity ratio may be obtained as follows:

$$\frac{\text{angular velocity } d}{\text{angular velocity } c} = \frac{C \dots cd}{D \dots cd}$$

also,
$$\frac{\text{angular velocity } b}{\text{angular velocity } d} = \frac{D \dots bd}{B \dots bd}$$

Multiplying,
$$\frac{\text{angular velocity } b}{\text{angular velocity } c} = \frac{C \dots cd \times D \dots bd}{D \dots cd \times B \dots bd}$$

The numerator of the last term consists of the product of the radii of the "followers," and the denominator consists of the product of the radii of the "drivers." The diameters or numbers of teeth could be substituted for the radii.

In general, the angular velocity of the first driver is to the angular velocity of the last follower as the product of the number of teeth of the followers is to the product of the number of teeth of the drivers. This applies equally well to compound spur-gear trains that have more than three axes.* Therefore, in *any* spur-gear chain the velocity ratio equals the product of the number of teeth in the followers divided by the product of the number of teeth in the drivers. The direction of rotation is reversed if the number of intermediate axes is even, and is not reversed if the number is odd. If the train includes annular gears their axes would be omitted from the number, because annular gears do not reverse the direction of rotation.

* Epicyclic trains excepted.

CHAPTER XVIII.

SPRINGS.

211. Springs Defined.—Usually machine members are required to sustain the applied forces without appreciable yielding and are designed accordingly; but certain machine members are useful because of considerable yielding. They are generally called springs.

212. Illustrations.—(a) The spring of a safety-valve on a steam-boiler holds the valve down until the steam-pressure reaches the maximum allowable value; then it yields and allows steam to escape until the pressure is reduced, when it closes the valve.

(b) The springs upon which a locomotive-engine is supported prevent the transmission of the full effect of the shocks, due to running, to the working parts of the engine, thereby reducing the resulting stresses. Car-springs in a similar manner protect passengers and freight.

(c) “Bumper” springs reduce stresses in cars and their contents due to axial shocks.

(d) The springs in certain steam-engine governors yield under the increased centrifugal force of the governor weights, due to increased rotative speeds, and allow the adjustment of the valve-gear to the changes of effort and load.

(e) Heavy reciprocating parts are often brought to rest without shock and are then helped to start on their return travel by the expanding spring.

(f) A power-hammer strikes a “cushioned blow” because of the action of a spring. This spring may be of steel, rubber, or steam.

(g) Belt connections are really yielding members and tend

to reduce shocks transmitted through them; while gears (except rawhide or "hard-fiber") yield almost imperceptibly and transmit shocks almost unchanged.

(*h*) Long bolts may become springs for the reduction of stress due to shock.

(*i*) Springs may serve for the storing of energy which is given out slowly to actuate light-running mechanisms, like clocks.

213. Cantilever Springs.—Many springs are simple cantilevers with end loads. (See Fig. 234.)

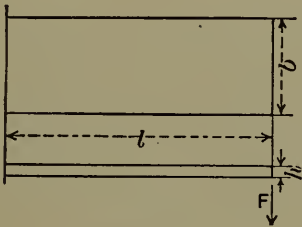

FIG. 234.

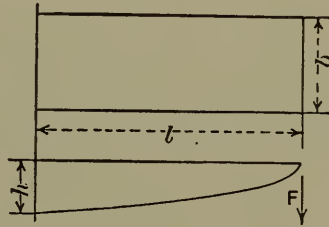

FIG. 235.

The rectangular spring of constant width b and height (or thickness) h , with a load F applied at a distance l from the support gives, from the laws of beams,

$$F = \frac{f b h^2}{6l} \quad \text{and} \quad \Delta = \frac{4Fl^3}{E b h^3}.$$

f is the unit stress in the outer fiber in pounds per square inch, all forces being expressed in pounds and all dimensions in inches; Δ is the total deflection in inches due to the application of F ; E is the modulus of elasticity of the material used.

For a flat spring of uniform breadth b , rectangular cross-section, top surface flat and lower surface a parabola in outline, such as is shown in Fig. 235,

$$F = \frac{f b h^2}{6l} \quad \text{and} \quad \Delta = \frac{6Fl^3}{E b h^3}.$$

The same equations hold approximately for the cantilever spring shown in Fig. 236. They also hold for the triangular spring of constant depth h shown in Fig. 237.

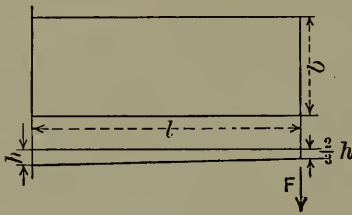

FIG. 236.

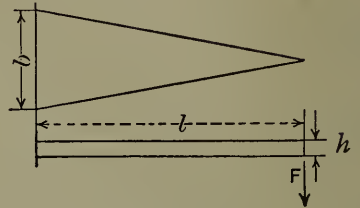

FIG. 237.

In all of these cases obviously the yielding varies inversely as h^3 , and the strength directly as h^2 ; hence, if h be increased to obtain required strength, the yielding will be decreased as the cube of h while the strength is increased only as the square of h . Much of the requisite yielding is therefore sacrificed if the strength is obtained by increasing h .

Inspection of the same equations shows that increasing the breadth b to obtain the required strength decreases the deflection in the same proportion. In springs, therefore, where yielding is to be kept large, it is better to gain requisite strength by varying b ; while in a beam h should be as large as possible because here deflection is to be reduced to the smallest value. If the spring is to be of tool steel, hardened and tempered, thin material is better suited to the operation of hardening.

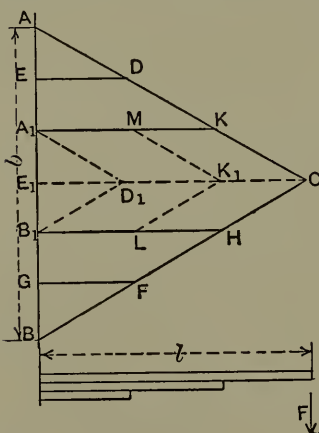

FIG. 238.

As b is increased with a constant small value of h , it may become too great for the available space. This difficulty is overcome as shown by reference to Fig. 238.

Suppose ABC is a triangular spring designed for certain con-

ditions of load and yielding. AB is an inconvenient width. Divide AB into equal parts, say six. Conceive the portion $GFHB_1$ cut off and placed in the position $B_1LK_1E_1$, and similarly conceive that $EDKA_1$ occupies the position $A_1MK_1E_1$, and the two parts are rigidly joined along the line K_1E_1 . Also conceive the portion ADE moved to $A_1D_1E_1$, and BFG moved to $B_1D_1E_1$, and that they are rigidly joined along the line D_1E_1 .

The amount of material is unchanged. The bending force is applied in *nearly* the same way to the portions whose position is changed. The *leaf spring* is therefore practically equivalent to the triangular spring from which it is made.

214. Springs for Axial Loads.—Many springs are subjected to axial loads; they are usually helical in form as shown in Fig. 239.

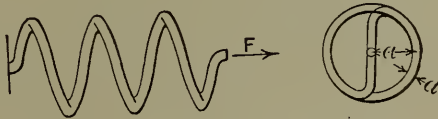

FIG. 239.

F may act to stretch or compress the spring.

Consider the cross-section of the rod to be circular.

Let F = load in pounds;

d = diameter of rod in inches;

a = mean radius of coil in inches;

N = number of coils;

l = developed length of spring in inches = $2\pi aN$;

f_s = allowable unit shearing stress in outer fiber in pounds per square inch;

E_s = modulus of shearing elasticity = $\frac{2}{3}E$;

Δ = extension or compression in inches.

Then the following equations may be developed:

$$d = \sqrt[3]{\frac{16Fa}{f_s\pi}}, \quad \Delta = \frac{32Fa^2l}{\pi d^4 E_s}, \quad \text{and} \quad N = \frac{\Delta d^4 E_s}{64Fa^3}.$$

In a helical spring for an axial load using a rectangular cross-section of wire the axial height of wire = h and radial breadth = b , the equations become

$$F = \frac{f_s}{3a} \frac{b^2 h^2}{\sqrt{b^2 + h^2}}, \quad \Delta = 3 \frac{F a^2 l}{E_s} \cdot \frac{b^2 + h^2}{b^2 h^2}, \quad \text{and} \quad N = \frac{\Delta E_s}{6\pi F a^3} \cdot \frac{b^2 h^2}{b^2 + h^2}.$$

It will take one and a half times as much material to make a spring of this type as it would to make a round-wire helical spring of equal strength.

215. Springs for Torsional Movements.—Many springs come

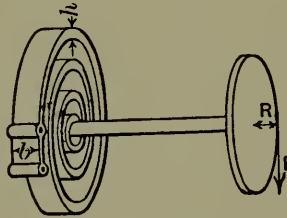

FIG. 240.

under class (i) as mentioned above. The general case is shown in Fig. 240. The spring is a spiral of flat wire with an axial height b and radial depth h .

F = turning force in pounds;

R = lever-arm in inches;

f = unit stress in outer fiber, pounds per square inch;

l = developed length of spring;

ϑ = angular deflection;

Δ = distance in inches moved through by the point of application of F .

$$\text{Then} \quad F = \frac{f b h^2}{6R} \quad \text{and} \quad \Delta = R \vartheta = \frac{12 F l R^2}{E b h^3}.$$

For further information the reader is referred to Reuleaux's "Constructor" and Trans. A. S. M. E., Vols. V and XVI.

CHAPTER XIX.

MACHINE SUPPORTS.

216. General Laws for Machine Supports.—The single-box pillar support is best and simplest for machines whose size and form admit of its use. When a support is a single continuous member, its design should be governed by the following principles:

I. The amount of material in the cross-section is determined by the intensity of the load. If vibrations are also to be sustained, the amount of material must be increased for this purpose.

II. The vertical center line of the support should coincide with the vertical line through the center of gravity of the part supported.

III. The vertical outlines of the support should taper slightly and uniformly on all sides. If they were parallel they would appear nearer together at the bottom.

IV. The external dimensions of the support must be such that the machine has the appearance of being in stable equilibrium. The outline of all heavy members of the machine supported must be either carried without break to the foundation, or if they overhang, must be joined to the support by means of parabolic outlines, or by the straight lines of the brace form.

217. Illustration.—In Fig. 241 the first three principles may be fulfilled, but there is an appearance of instability. It is because the outline of the “housing” overhangs. It should be carried to the foundation without break in the continuity of the metal, as in Fig. 242.

218. **Divided Supports.**—When the support is divided up into several parts, modification of these principles becomes necessary, as the divisions require separate treatment. This question may

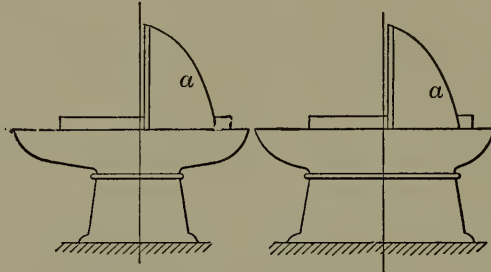

FIG. 241.

FIG. 242.

be illustrated by lathe supports. In Fig. 243 are shown three forms of support for a lathe, seen from the end. For stability the base needs to be broader than the bed. In *A* the width of base necessary is determined and the outlines are straight lines. The unnecessary material is cut away on the inside, leaving legs which are compression members of correct form. The cross-brace is left to check any tendency to buckle. For convenience to the workmen it is desirable to narrow this support somewhat

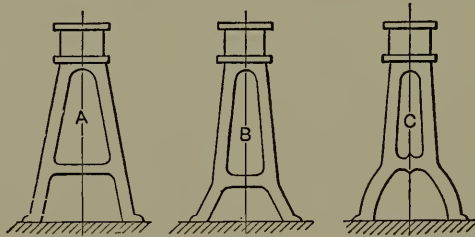

FIG 243.

without narrowing the base. The cross-brace converts the single compression member into two compression members. It is allowable to give these different angles with the vertical. This is done in *B* and the straight lines are blended into each other by a curve. *C* shows a common incorrect form of lathe support, the compression members from the cross-brace downward being curved. There is no reason for this curved form. It is less capable of

bearing its compressive load than if it were straight, and is no more stable than the form *B*, the width of base being the same.

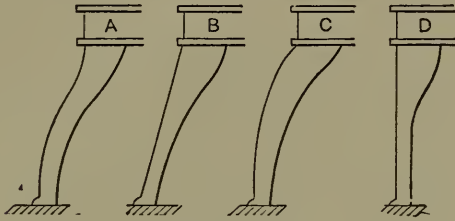

FIG. 244.

Consider the lathe supports from the front. Four forms are shown in Fig. 244. If there were any force tending to move the bed of the lathe endwise the forms *B* and *C* would be allowable. But there is no force of this kind, and the correct form is the one shown in *D*. Carrying the foot out as in *A*, *B*, and *C* increases the distance between supports (the bed being a beam with end supports and the load between); this increases the deflection and the fiber stress due to the load. This increase in stress is probably not of any serious importance, but the principle should be regarded or the appearance of the machine will not be right. If the supports were joined by a cross-member,

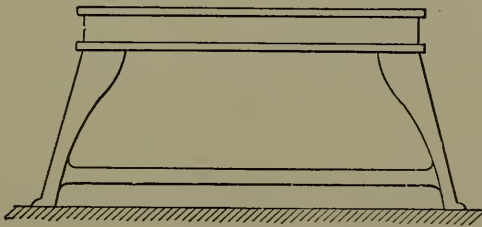

FIG. 245.

as in Fig. 245, they would be virtually converted into a single support, and should then taper from all sides.

219. Three-point Support.—If a machine be supported on a single-box pillar, change in the form of the foundation cannot induce stress in the machine frame tending to change its form. If, however, the machine is supported on four or more legs the

foundation might sink away from one or more of them and leave a part unsupported. This might cause torsional or flexure stress in some part of the machine, which might change its form and interfere with the accuracy of its action.

But if the *machine is supported on three points* this cannot occur, because if the foundation should sink under any one of the supports the support would follow and the machine would still rest on three points. When it is possible, therefore, a machine which cannot be carried on a single pillar should be supported on three points. Many machines are too large for three-point support, and the resource is to make the bed, or part supported, of box section and so rigid that even if some of the legs should be left without foundation the part supported would still maintain its form. More supports are often used than are necessary. Thus, if a lathe has two pairs of legs like those shown in *B*, Fig. 243, and these are bolted firmly to the bed, there will be four points of support. But if, as suggested by Professor Sweet, one of these pairs be connected to the bed by a pin so that the support and the bed are free to move relatively to each other about the pin, as in Fig. 246, then this is equivalent to a single support, and the bed will have three points of support, and will maintain its form independently of any change in the foundation. This is of special importance when the machines are to be placed upon yielding floors.

220. Reducing Number of Supports.—Fig. 247 shows another



FIG. 246.

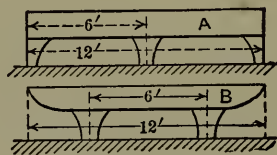

FIG. 247.

case in which the number of supports may be reduced without sacrifice. In *A* three pairs of legs are used. There are therefore

six points of support. In *B* two pairs of legs are used and one may be connected by a pin, and there will be but three points of support. The chance of the bed being strained from changing foundation has been reduced from 6 in *A* to 0 in *B*. The total length of bed is 12 feet, and the unsupported length is 6 feet in both cases.

221. **Further Correct Methods.**—Figs. 248 and 249 show correct methods of support for small lathes and planers, due to

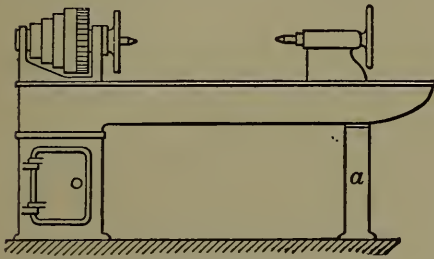

FIG. 248.

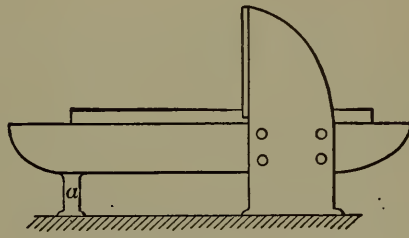

FIG. 249.

Professor Sweet. In Fig. 248 the lathe “head-stock” has its outlines carried to the foundation by the box pillar; *a* represents a pair of legs connected to the bed by a pin connection, and instead of being placed at the end of the bed it is moved in somewhat, the end of the bed being carried down to the support by a parabolic outline. The unsupported length of bed is thereby decreased, the stress on the bed is less, and the bed will maintain its form regardless of any yielding of the floor or foundation. In Fig. 249 the housings, instead of resting on the bed as is usual in small planers, are carried to the foundation, forming two of the supports; the other is at *a* and has a pin connection with the bed, which being thus supported on three points cannot be twisted or flexed by a yielding foundation.

CHAPTER XX.

MACHINE FRAMES.

222. **Open-side Frame.**—Fig. 250 shows an open-side frame, such as is used for punching and shearing machines. During the action of the punch or shear a force is applied to the frame tending to separate the jaws. This force may be represented in magnitude, direction, and line of action by P . It is required to find the resulting stresses in the three sections AB , CD , and EF . Consider AB . Let the portion above this section be taken as a free body. The force P , Fig. 251, and the opposing resistances to

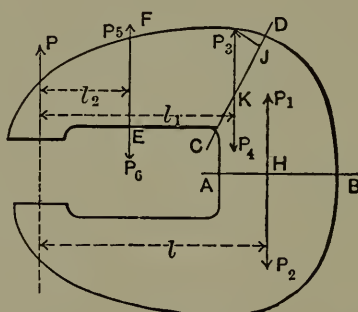

FIG. 250.

deformation of the material at the section AB , are in equilibrium. Let H be the projection of the gravity axis of the section AB , perpendicular to the paper. Two equal and opposite forces, P_1 and P_2 , may be applied at H without disturbing the equilibrium. Let P_1 and P_2 be each equal to P , and let their line of action be parallel to that of P . The free body is now subjected to the action of an external couple, Pl , and an external force, P_1 . The

couple produces flexure about H , and the force P_1 produces tensile stress in the section AB . The flexure results in a tensile stress varying from a maximum value in the outer fiber at A to zero at H , and a compressive stress varying from a maximum in the outer fiber at B to zero at H . This may be shown graphically at JK . The ordinates of the line LM represent the varying stress due to flexure; while ordinates between LM and NO represent the uniform tensile stress. This latter diminishes the compressive stress at B , and increases the tensile stress at A . The tensile stress per square inch at A therefore equals $f+f_1$; where f equals the unit fiber stress due to flexure at A , and f_1

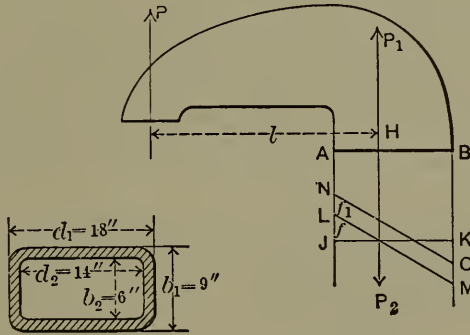

FIG. 252.

FIG. 251.

equals the unit tensile stress due to P_1 . Now $f = \frac{Plc}{I}$, and $f_1 = \frac{P}{A}$; in which c = the distance from the gravity axis to the outer fiber = AH , and I = the moment of inertia of the section about H , and A = area of the cross-section AB .

223. Problem.—Let it be required to design the frame of a machine to punch $\frac{3}{4}$ -inch holes in $\frac{1}{2}$ -inch steel plates, 18 inches from the edge. The surface resisting the shearing action of the punch = $\pi \times \frac{3}{4}'' \times \frac{1}{2}'' = 1.18$ square inch. The ultimate shearing strength of the material is say 50,000 lbs. per square inch. The total force P , which must be resisted by the punch frame = $50,000 \times 1.18 = 59,000$ lbs.

The material and form for the frame must first be selected. The form is such that forged material is excluded, and difficulties of casting and high cost exclude steel casting. The material, therefore, must be cast iron. Often the same pattern is used both for the frame of a punch and shear. In the latter case, when the shear blade begins and ends its cut, the force is not applied in the middle plane of the frame, but considerably to one side, and a torsional stress results in the frame. Combined torsion and flexure are best resisted by members of box form. The frame will therefore be made of cast iron and of box section. The dimension AB may be assumed so that its proportion to the "reach" of the punch appears right; the width and thickness of the cross-section may also be assumed. From these data the maximum stress in the outer fiber may be determined. If this is a safe value for the material used the design will be right.

Let the assumed dimensions be as shown in Fig. 252. Then

$$A = b_1d_1 - b_2d_2 = 78 \text{ square inches.}$$

$$I = \frac{b_1d_1^3 - b_2d_2^3}{12} \\ = 3002 \text{ bi-quadratic inches.}$$

$c = d_1 \div 2 = 9''$; $l =$ the reach of the punch $+ c = 27''$; $P = 59,000$ lbs., as determined above. Then

$$f_1 = \frac{P}{A} = \frac{59000}{78} = 756,$$

$$f = \frac{Plc}{I} = \frac{59000 \times 27 \times 9}{3002} = 4776,$$

$$f_1 + f = 5532 = \text{maximum stress in the section.}$$

The average strength of cast iron such as is used for machinery castings, is about 20,000 lbs. per square inch. The factor of safety in the case assumed equals $20,000 \div 5532 = 3.65$. This is too small. There are two reasons why a large factor of safety

should be used in this design: I. When the punch goes through the plate the yielding is sudden and a severe stress results. This stress has to be sustained by the frame, which for other reasons is made of unresilient material. II. Since the frame is of cast iron, there will necessarily be shrinkage stresses which the frame must sustain in addition to the stress due to external forces. These shrinkage stresses cannot be calculated and therefore can only be provided against by a large factor of safety.

Cast iron is strong to resist compression and weak to resist tension, and the maximum fiber stress is tension on the inner side. The metal can therefore be more satisfactorily distributed than in the assumed section, by being thickened where it sustains tension, as at *A*, Fig. 253. If, however, there is a very thick body of metal at *a*, sponginess and excessive shrinkage would result. The form *B* would be better, the metal being arranged for proper cooling and for the resisting of flexure stress.

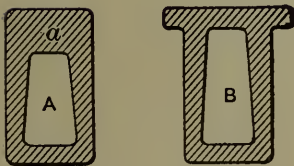

FIG. 253.

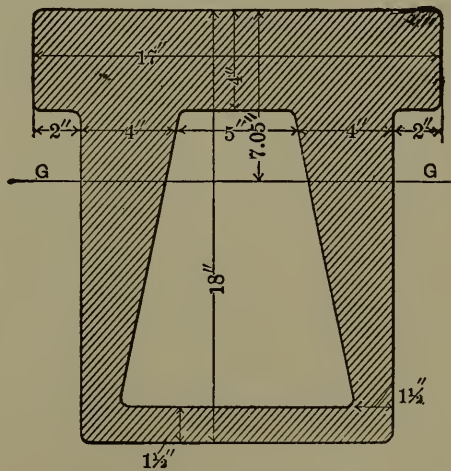

FIG. 254.

Dimensions may be assigned to a section like *B* and the cross-section may be checked for strength as before. See Fig. 254. *GG*, a line through the center of gravity of the section, is found to be at a distance of 7.05 inches from the tension side.* The

* A simple and satisfactory method for obtaining a close approximation to

required values are as follows: $c = 7.05$ inches; $l =$ reach of punch $+ c = 18 + 7.05 = 25.05$ inches; $A = 156.25$ square inches; $I = 5032.5$ bi-quadratic inches; $P = 59,000$ lbs.

Then
$$f_1 = \frac{P}{A} = \frac{59000}{156.25} = 377.6 \text{ lbs.};$$

$$f = \frac{Plc}{I} = \frac{59000 \times 25.05 \times 7.05}{5032.5} = 2070.4 \text{ lbs.}$$

$f_1 + f = 2448$ lbs. = maximum fiber stress in the section. The factor of safety $= 20,000 \div 2448 = 8.17$.* This section, therefore, fulfills the requirement for strength, and the material is well arranged for cooling with little shrinkage, and without spongy spots. The gravity axis may be located, and the value of I determined by graphic methods. See Hoskins's "Graphic Statics." †

Let the section CD , Fig. 250, be considered. Fig. 255 shows the part at the left of CD free. K is the projection of the gravity axis of the section. As before, put in two opposite forces, P_3 and P_4 , equal to each other and to P , and having their common line of action parallel to that of P , at a distance l_1 from it. P and P_4 now form a couple, whose moment $= Pl_1$, tending to produce flexure about K . P_3 must be resolved into two components, one P_3J , at right angles to the section considered, tending to produce tensile stress; and the other JK , parallel to the section, tending to produce shearing stress. The greatest unit tensile

the true gravity axis of irregular figures is as follows: On a piece of thin but uniform cardboard lay out the figure to scale. Cut it out carefully with a sharp knife. Balance the figure exactly, by trial, on a knife-edge. The line of contact with the knife-edge is the gravity axis. Its position may be marked and its location measured to scale.

* This discussion neglects the action of gravity which would exert a counterbalancing moment, reducing the maximum tensile fiber stress below the value found. This makes the actual factor of safety greater than the apparent factor of safety.

† The student will be familiar with analytical methods for their determination from his study of the "Mechanics of Materials."

stress in this section will equal the sum of that due to flexure and that due to tension

$$= f + f_1 = \frac{Pl_1c}{I} + \frac{P_3J}{A}.$$

The greatest unit shear $= f_s = \frac{JK}{A}.$

In the section *FE*, Fig. 250, which is parallel to the line of action of *P*, equal and opposite forces, each = *P*, may be introduced, as *P*₅ and *P*₆. *P* and *P*₆ will then form a couple with an

FIG. 255.

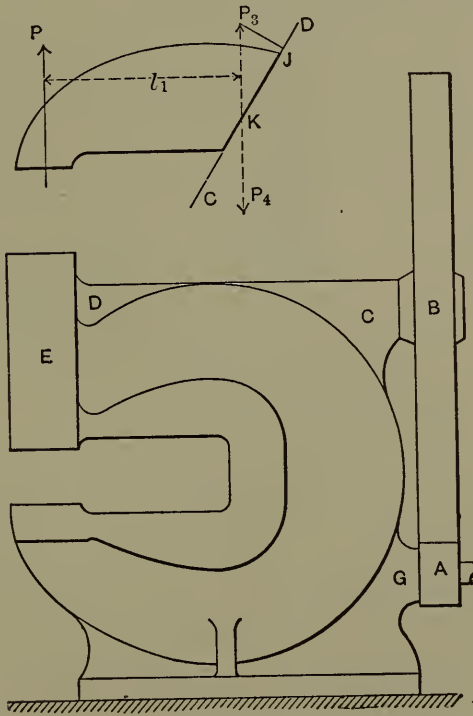

FIG. 256.

arm *l*₂, and *P*₅ will be wholly applied to produce shearing stress. The maximum unit tensile stress in this section will be that due to flexure, $f = Pl_2c \div I$, and the maximum unit shear will be $f_s = P \div A$. Any section may be thus checked.

The dimensions of several sections being found, the outline curve bounding them should be drawn carefully, to give good appearance. The necessary modifications of the frame to provide for support, and for the constraint of the actuating mechanism, may be worked out as in Fig. 256. *A* is the pinion on the pulley shaft from which the power is received; *B* is the gear on the main shaft; *C*, *D*, and *G* are parts of the frame added to supply bearings for the shafts; *E* furnishes the guiding surfaces for the punch "slide." The method of supporting the frame is shown, the support being cut under at *F* for convenience to the workman. The parts *C*, *D*, *E*, and *G* can only be located after the mechanism train has been designed.

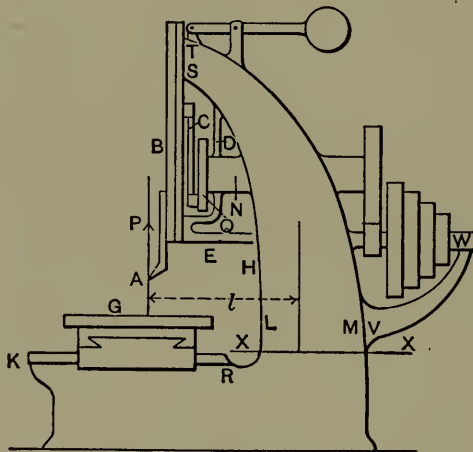

FIG. 257.

224. Slotting-machine Frame.—See Fig. 257. It is specified that the slotter shall cut at a certain distance from the edge of any piece, and the dimension *AH* is thus determined. The table *G* must be held at a convenient height above the floor, and *RK* must provide for the required range of "feed." *K* is cut under for convenience of the workman, and carried to the floor line as shown. It is required to "slot" a piece of given vertical dimension, and the distance from the surface of the table to *E* is thus determined. Let the dimension *LM* be assumed so that

it shall be in proper proportion to the necessary length and height of the machine. The curves LS and MT may be drawn for bounding lines of a box frame to support the mechanism. M should be carried to the floor line as shown, and *not cut under*. None of the part DNE , nor that which serves to support the cone and gears on the other side of the frame, should be made flush with the surface $LSTM$, because nothing should interfere with the continuity of the curves LS and TM . *The supporting frame of a machine should be clearly outlined, and other parts should appear as attachments.* The member VW should be designed so that its inner outline is nearly parallel to the outline of the cone pulley, and should be joined to the main frame by a curve. The outer outline should be such that the width of the member increases slightly from W to V , and should also be joined to the main frame by a curved outline. In any cross-section of the frame, as XX , the amount of metal and its arrangement may be controlled by the core. It is dictated by the maximum force, P , which the tool can be required to sustain. The tool is carried by the slider of a slider-crank chain. Its velocity varies, therefore, from a maximum near mid-stroke, to zero at the upper and lower ends of its stroke. The belt which actuates the mechanism runs on one side of the steps of the cone pulley, at a constant velocity. Suppose that the tool is set (accidentally) so that it strikes the table just before the slider has reached the lower end of its stroke. The resistance, R , offered by the tool to being stopped, multiplied by its (very small) velocity, equals the difference of belt tension multiplied by the belt velocity (friction and inertia neglected).^{*} R , therefore, would vary inversely as the slider velocity, and hence may be very great. Its maximum value is indeterminate. A "breaking piece" may be put in between the tool and the crank. Then when R reaches a certain value, the breaking piece fails.

* See Chapter V.

The stress in the stress-members of the machine is thereby limited to a certain definite value. From this value the frame may be designed. Let P = upward force against the tool when the breaking piece fails.* Let l = the horizontal distance from the line of action P to the gravity axis of the section XX . Then the section XX sustains flexure stress caused by the moment Pl , and tensile stress equal to P . The maximum unit stress in the section

$$= f + f_1 = \frac{Plc}{I} + \frac{P}{A}.$$

A section may be assumed and checked for safety, as for the punching-machine in § 223.

225. Stresses in the Frame of a Side-crank Steam-engine.— Fig. 258 is a sketch in plan of a side-crank engine of the “girder

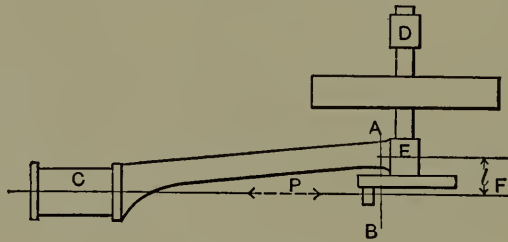

FIG. 258.

bed” type. The supports are under the cylinder C , the main bearing E , and the out-board bearing D . A force P is applied in the center line of the cylinder, and acts alternately toward the right and toward the left. In the first case it tends to separate the cylinder and main shaft; and in the second case it tends to bring them nearer together. The frame resists these tendencies with resulting internal stresses.

Let the stresses in the section AB be considered. The end of the frame is shown enlarged in Fig. 259. If the pressure from the piston is toward the right, the stresses in AB will be: I. Flexure

* P is limited to the friction due to screwing up the four bolts which hold the tool.

due to the moment Pl , resulting in tensile stress below the gravity axis, N , with a maximum value at b , and a compressive stress above N with a maximum value at a . II. A direct tensile stress, $=P$, distributed over the entire section, resulting in a unit stress $= P \div A = f_1$ lbs. per square inch. This is shown graphically at n , Fig. 259. a_1b_1 is a datum line whose length equals ab . Tensions are laid off toward the right and compressions toward the left.

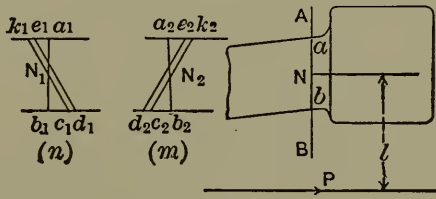

FIG. 259.

The stress due to flexure varies directly as the distance from the neutral axis N_1 , being zero at N_1 . If, therefore, b_1c_1 represents the tensile stress in the outer fiber, then c_1k_1 drawn through N_1 will be the locus of the ends of horizontal lines, drawn through all points of a_1b_1 , representing the intensity of stress in all parts of the section, due to flexure. If c_1d_1 represent the unit stress due to direct tension, then, since this is the same in all parts of the section, it will be represented by the horizontal distance between the parallel lines c_1k_1 and d_1e_1 . This uniform tension increases the tension b_1c_1 due to flexure, causing it to become b_1d_1 ; and reduces the compression k_1a_1 , causing it to become e_1a_1 . The maximum stress in the section is therefore tensile stress in the lower outer fiber, and is equal to b_1d_1 .

When the force P is reversed, acting toward the left, the stresses in the section are as shown at m , Fig. 259: compression due to flexure in the lower outer fiber equal to c_2b_2 ; tension due to flexure in the upper outer fiber equal to a_2k_2 ; and uniform compression over the entire surface equal to d_2c_2 . This latter increases the compression in the lower outer fiber from b_2c_2 to b_2d_2 , and decreases the tension in the upper outer fiber from a_2k_2

to a_2e_2 . The maximum stress in the section is therefore compression in the lower outer fiber equal to b_2d_2 . The maximum stress, therefore, is always in the side of the frame next to the connecting-rod.

If the gravity axis of the cross-section be moved toward the connecting-rod, the stress in the upper outer fiber will be increased, and that in the lower outer fiber will be proportionately decreased. The gravity axis may be moved toward the connecting-rod by increasing the amount of material in the lower part of the cross-section and decreasing it in the upper part.

The stress in any other section nearer the cylinder will be due to the same force, P , as before; but the moment tending to produce flexure will be less, because the lever arm of the moment is less and the force constant.

226. Heavy-duty Engine Frame.—Suppose the engine frame to be of the type which is continuous with the supporting part as shown in Fig. 260. Let Fig. 261 be a cross-section, say at AB . O is the center of the cylinder. The force P is applied at this

FIG. 260.

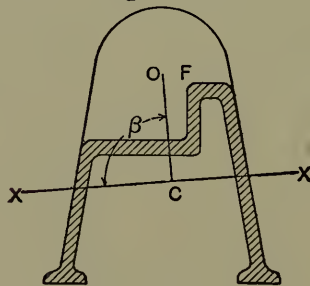
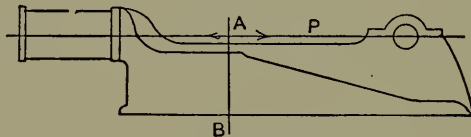

FIG. 261.

point perpendicular to the paper. C is the center of gravity of the section (the intersection of two gravity axes perpendicular to each other, found graphically). Join C and O , and through

C draw XX perpendicular to CO . Then XX is the gravity axis about which flexure will occur.* The dangerous stress will be at F , and the value of c will be the perpendicular distance from F to XX . The moment of inertia of the cross-section about XX may be found, $=I$; l , the lever-arm of P , $=OC$. The stress at F , $f+f_1$ must be of safe value.

$$f = \frac{Plc}{I}, \quad \text{in known terms.}$$

$$f_1 = \frac{P}{\text{area of section}}, \quad \text{in known terms.}$$

227. Closed Frames.—Fig. 262 shows a closed frame. The members G and H are bolted rigidly to a cylinder C at the top, and to a bedplate, DD , at the bottom. A force P may act in the center line, either to separate D and C , or to bring them nearer together. The problem is to design G , H , and D for strength. If the three members were “pin connected” (see Fig. 263), the reactions of C upon A and B at the pins would act in the lines EF and GH . Then if P acts to bring D and C nearer together, compression results in A , the line of action being EF ; compression results in B , the line of action being GH . These compressions being in equilibrium with the force P , their magnitude may be found by the triangle of forces. From these values A and B may be designed, C is equivalent to a beam whose length is l , supported at both

* This is not strictly true. If OC is a diameter of the “ellipse of inertia,” flexure will occur about its conjugate diameter. If the section of the engine frame is symmetrical with respect to a vertical axis, OC is vertical, and its conjugate diameter XX is horizontal. Flexure would occur about XX , and the angle between OC and XX would equal 90° . As the section departs from symmetry about a vertical, XX , at right angles to OC , departs from OC 's conjugate, and hence does not represent the axis about which flexure occurs. In sections like Fig. 259, the error from making $\beta=90^\circ$ is unimportant. When the departure from symmetry is very great, however, OC 's conjugate should be located and used as the axis about which flexure occurs. For method of drawing “ellipse of inertia” see Hoskins's “Graphic Statics.”

ends, sustaining a transverse load P , and tension equal to the horizontal component of the compression in A or B . The data for its design would therefore be available. Reversing the direction of P reverses the stresses; the compression in A and B becomes tension; the flexure moment tends to bend C convex downward instead of upward, and the tension in C becomes compression.

But when the members are bolted rigidly together, as in

FIG. 262.

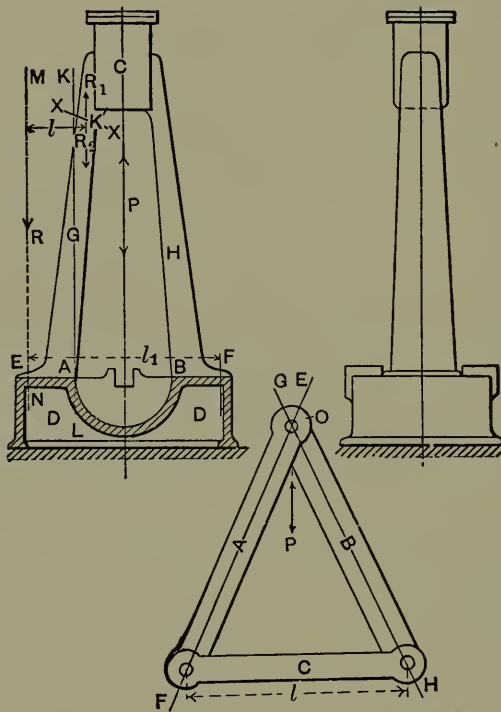

FIG. 263.

Fig. 262, the lines of the reactions are indeterminate. Assumptions must therefore be made. Suppose that G is attached to D by bolts at E and A . Suppose the bolts to have worked slightly loose, and that P tends to bring C and D nearer together. There would be a tendency, if the frame yields at all, to relieve pressure at E and to concentrate it at A . The line of the reaction would pass through A and might be assumed to be perpendicular to

the surface AE . Suppose that P is reversed and that the bolts at A are loosened, while those at E are tight. The line of the reaction would pass through E , and might be assumed to be perpendicular to EA . MN is therefore the assumed line of the reaction, and the intensity $R = P \div 2$. In any section of G , as XX , let K' be the projection of the gravity axis. Introduce at K' two equal and opposite forces equal to R and with their lines of action parallel to that of R . Then in the section there is flexure stress due to the flexure moment Rl , and tensile stress due to the component of R_2 perpendicular to the section, $=R_3$. Then the maximum stress in the section $=f + f_1$.

$$f = \frac{R_3}{A}; \quad f_1 = \frac{Rlc}{I}.$$

A section may be assumed, and A , I , and c become known; the maximum stress also becomes known, and may be compared with the ultimate strength of the material used.

Obviously this resulting maximum stress is greater when the line of the reaction is MN than when it is KL . Also it is greater when MN is perpendicular to EA than if it were inclined more toward the center line of the frame. The assumptions therefore give safety. If the force P could only act downward, as in a steam hammer, KL would be used as the line of the reaction.

The part D in the bolted frame is not equivalent to a beam with end supports and a central load like C , Fig. 263, but more nearly a beam built in at the ends with central load, and it may be so considered, letting the length of the beam equal the horizontal distance from E to F , $=l_1$. Then the stress in the mid-section will be due to the flexure moment $\frac{Pl_1}{8}$, and the maximum stress $=f = \frac{Pl_1c}{8I}$. The values c and I may be found for an assumed section, and f becomes known.

228. Steam-hammer Frames.—Steam-hammers are made both with “open-side ” and “closed ” frames. They may therefore be designed by methods already given, if the maximum force applied is known. The problem is, therefore, to find the value of this maximum force.

There are two types of steam-hammers:

Type 1. Single-acting. A heavy hammer-head attached to a steam-piston is raised to a certain height by steam admitted under the piston. The steam is then exhausted and the hammer-head with attached parts falls by gravity to its original position. The energy of the blow = Wl , where W is the falling weight and l is the height of fall.

Type 2. Double-acting. A lighter hammer-head is lifted by steam acting under its attached piston, and during its fall steam is admitted above the piston to help gravity to force it downward. The energy of the blow = Wl (as before) plus the energy received from the expansion of the steam; or, if the steam acts throughout the entire stroke, the energy of blow = $Wl + pAl$, where p is the mean pressure per square inch and A is the area of the upper side of the piston.

229. Stresses in Single-acting Frames.—In type 1, when the action is as described, a force acts downward upon the frame during the lifting of the hammer. The intensity of this force = pA = the mean pressure of steam admitted multiplied by area of piston, and the line of action is the axis of the piston-rod. During the fall of the hammer the cylinder and frame act simply as a guide, and no force is applied to the frame except such as may result from frictional resistance. The hammer strikes an anvil which is not attached to the frame, but rests upon a separate foundation.

But a greater force than pA may be applied to the frame. In order that a cushioned blow may be struck, the design is such that steam may be introduced under the piston at any time during its downward movement, and this steam is compressed by the

advancing piston. A part of the energy of the falling hammer is used for this compression. The pressure in the cylinder resulting from this compression is communicated to the lower cylinder-head and through it to the frame. Under certain conditions steam might be admitted at such a point of the stroke that *all* of the energy of the falling hammer might be used in compressing the steam to the end of the stroke. The hammer would then just reach the anvil, but would not strike a blow.

Fig. 264, *a* shows by diagram a hammer of type 1. Steam is admitted, the piston is raised, the exhaust-valve is opened, and

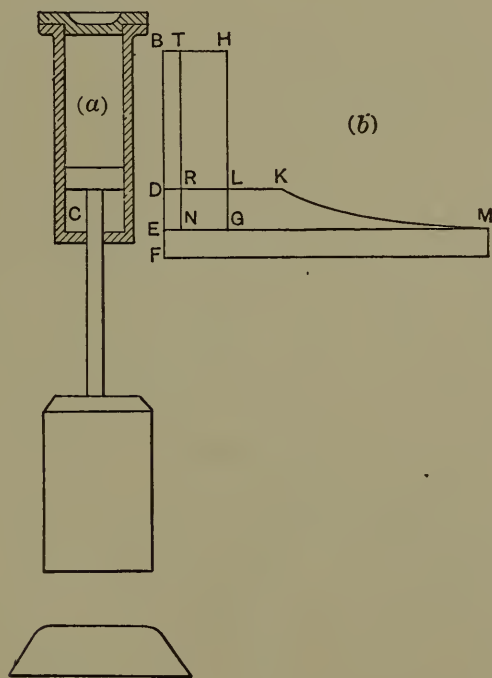

FIG. 264.

the piston falls. But at some point in the stroke steam is again admitted, filling the cylinder, and the valve is closed. Compression occurs and absorbs all or part of the energy Wl . In the latter case the hammer will strike the anvil a blow whose energy is equal to Wl minus the work of compressing the steam in *C*.

The compression is shown upon a pressure-volume diagram, Fig. 264, *b*. Progress along the vertical axis from *B* toward *E* corresponds to the downward movement of the hammer. Vertical ordinates therefore represent space, *S*, moved through by the hammer; or, since $SA = \text{volume displaced by the piston}$, the vertical ordinates may also represent volumes. *EF* represents the volume V_2 of the clearance space, or $\frac{V_2}{A}$, the piston movement which corresponds to the clearance. Horizontal ordinates measured from *BF* represent absolute pressures per square inch. Let p_1 represent the absolute boiler pressure represented by *DK*. *TN* is the line of atmospheric pressure. During the lifting of the hammer the upper surface of the piston is exposed to atmospheric pressure and the lower surface is exposed to pressure just sufficient to raise the hammer, $= \frac{W}{A}$. The work of lifting is represented by the area *NTHG*. This work equals the energy, *Wl*, which the hammer must give out in some way before reaching the anvil again. When the piston has fallen to some point, as *D*, steam may be let in below it at boiler pressure, *DK*. The advancing piston will compress this steam, and *KM* will be the compression curve.* The work of compression is represented by the area *RKMN*. If the compression is to absorb all the energy *Wl*, the area which represents the work of compression must equal the area which represents *Wl*. Hence area *NTHG* must equal *RKMN*; or, since the area *RLGN* is common to both, the area *RTHL* must equal the area *LKMG*. The point at which compression must begin in order to cause this equality may be found by trial. The greatest unit pressure reached by compression is represented by *EM*. The greatest pressure, p_2 , upon the lower-cylinder-head is represented by *NM*, since atmospheric pressure

* Assuming $pV = \text{constant}$.

acts on the outside. The corresponding total force communicated to the frame $= p_2 A = P$.*

If compression had begun earlier the energy would have been absorbed before the hammer reached the anvil, the piston would have stopped short of the end of the stroke, the compression curve would have been incomplete, and the greatest pressure would have been less than EM : Obviously if compression had begun later the greatest pressure would have been less than EM . Therefore the force P , $= p_2 A$, with the cylinder's axis for its line of action, is the greatest force that can be applied to the frame in the regular working of the hammer.

A greater force might be accidentally applied. For, suppose that water is introduced into the cylinder in such quantity that the piston reaches it before the hammer reaches the anvil, then all the energy will be given out to overcome the resistance of the water. The resulting force is indeterminate, because the space through which the resistance acts is unknown. This force may be very great. The force applied to the frame may be limited by the use of a "breaking-piece." Thus the studs which hold on the lower cylinder-head may be drilled † so that they will break under a force KP , in which K is a factor of safety and P is the force found above. Then the breaking-piece will be safe under the maximum working force, but will yield when an accidental force equals KP , thus limiting its value. The frame may be designed for a maximum force KP .

230. Problem, Type 1.— Let W , weight of hammer and attached parts. = 2000 lbs.; l , maximum length of stroke, = 24 inches; A , effective area of piston, = 50 square inches; clearance = 15 per cent; boiler pressure = 85 lbs. by gauge. Steam is admitted to lift the hammer, pressure being controlled by throttling.

* In which A is the effective area of the piston, *i.e.*, area of the piston less area of the rod.

† See page 130.

The pressure per square inch that will just lift the hammer = $2000 \text{ lbs.} \div 50 \text{ square inches} = 40 \text{ lbs.}$ In Fig. 264, NG represents 40 lbs., and NT represents the volume displaced by the piston during a complete stroke. Hence $NTHG$ represents the work of lifting the hammer, or the energy that must be absorbed just as the hammer reaches the anvil. Trial shows that to accomplish this, compression must begin at just about 6 inches from the end of the stroke. The maximum resulting pressure, represented by NM , equals 258 lbs. per square inch. The total pressure acting downward on the frame = $p_2A = 258 \times 50 = 12,900 \text{ lbs.} = P$. If the factor of safety, K , is 5, the strength of the breaking-piece = $KP = 5 \times 12,900 = 64,500 \text{ lbs.}$ This is the maximum force, and hence may be used as a basis of the frame design.

231. Stresses in Double-acting Frames.—In type 2 the maximum working force may be found by a similar method. In Fig. 265, NG represents the pressure per square inch of piston necessary to raise the hammer. The area $NTHG$ represents the energy stored in the hammer by lifting. The area $HSJL$ represents the work done by steam at boiler pressure acting on the upper piston face while the piston descends to D . At this point steam is exhausted above the piston and let in below it, and compression takes place during the remainder of the stroke. To absorb all the energy of the hammer by compression, the areas $NTSJLG$ and $RKMN$ must be equal. The area $NRLG$ is common to both; hence the area $LKMG$ must equal the area $RTSJ$. The point at which compression must begin in order to cause this equality may be found by trial.

232. Problem, Type 2.—Let W , weight of hammer and attached parts, = 600 lbs.; l , maximum length of stroke, = 24 inches; A , effective area of piston (both faces), = 50 square inches; clearance = 15 per cent; boiler pressure = 85 lbs. by gauge. The construction in Fig. 265 shows that compression, beginning at $9\frac{1}{4}$ inches before the end of the piston's stroke, absorbs all

the energy of the hammer, and gives 325 lbs. as a maximum pressure per square inch. Then the maximum working force $= 325 \times 50 = 16,250$. If $K = 5$, the strength of the breaking-piece $= 16,250 \times 5 = 81,250$ lbs.

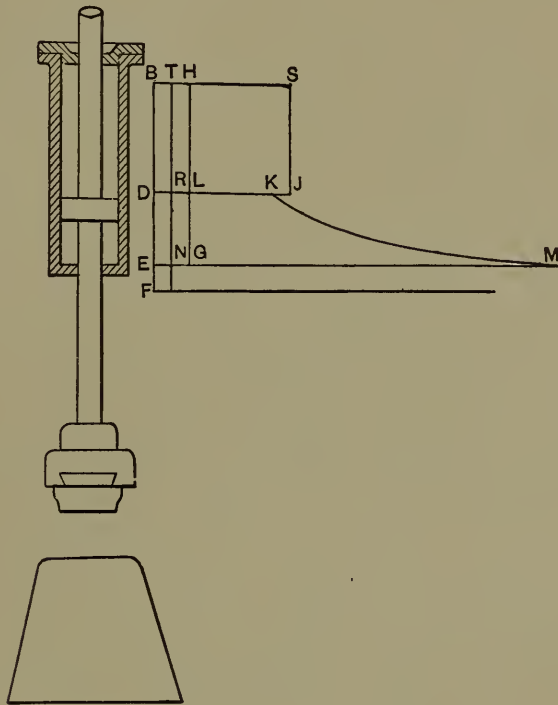

FIG. 265.

233. Other Stresses in Hammer Frames.—An accidental force acting upward may be applied to the hammer frame. The boiler pressure is necessarily greater than that which is necessary to lift the hammer.* Thus in § 230 a pressure of 40 lbs. per square inch is sufficient to lift the hammer, but the boiler pressure is 85 lbs. per square inch. If the throttle-valve were opened wide and held open during the movement of the hammer upward, the energy stored in the hammer when it reaches its upper position would equal the product of boiler pressure, piston area, and length of stroke, $= 85 \times 50 \times 24 = 106,000$ in.-lbs. The energy necessary

* So that it may be possible to work the hammer when the steam-pressure is lower in the boiler.

to just lift the hammer is $40 \times 50 \times 24 = 48,000$ in.-lbs. The difference between these two amounts of energy, $= 58,000$ in.-lbs., will exist as kinetic energy of the moving hammer; and it must be absorbed before the hammer can be brought to rest in its upper position. The force which would result from stopping the hammer would be dependent upon the space through which the motion of the hammer is resisted. Springs are often provided to resist the motion of the hammer when near its upper position. These springs increase the space factor of the energy to be given out and thereby reduce the resulting force. An automatic device for closing the throttle-valve before the end of the stroke and introducing steam for compression above the piston may be used. The steam is then a fluid spring.

234. Design of Crane Frames.—A crane frame is to be designed from the following specifications:—Maximum load, 5 tons $= 10,000$ lbs.; radius = maximum distance from the line of lifting to the axis of the mast, $= 18$ feet; height of mast $= 20$ feet; radial travel of hook in its highest position $= 5$ feet; axis of jib to be 15 feet above floor line. Fig. 266 shows the crane indicated by the center lines of its members.

The external forces acting on the crane may be considered first. A load of 10,000 lbs. acts downward in the line ab . This is held in equilibrium by three reactions: one acting horizontally toward the left through the upper support, *i.e.*, along the line bc ; another acting horizontally toward the right through the lower support, *i.e.*, in the line ad ; a third acting vertically upward at the lower support, *i.e.*, in the line cd . The crane is a “four-force piece.” One force, AB , is completely known, the other three are known only in line of action. Produce ab and bc to their intersection at M . The line of action of the resultant of ab and bc must pass through M . The resultant of cd and da must be equal and opposite to the resultant of ab and bc , and must have the same line of action. But the line of action of the resultant of cd and

da must pass through N . Hence MN is the common line of action of the resultants of ab and bc and of cd and da . Draw the vertical line AB * representing 10,000 lbs. upon some assumed scale; from B draw BC parallel to bc , and from A draw AC parallel to MN . The intersection of these two lines locates C and determines the magnitude of BC . Now AC is the resultant of AB and BC , and CA , equal and opposite, is the resultant of CD

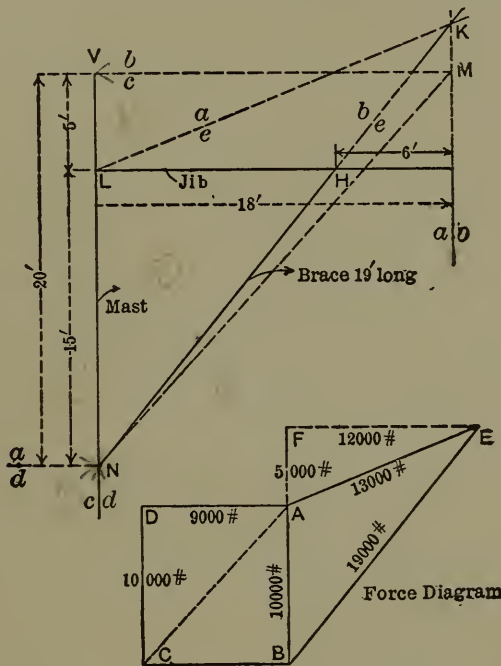

FIG. 266.

and DA . Therefore CA has but to be resolved into vertical and horizontal components to determine the magnitudes of CD and DA . The force polygon is therefore a rectangle and $CD = AB$, and $BC = DA$.

From the forces AD and CD acting at N , the supporting journal and bearing at the base of the crane may be designed; and from the force BC , acting at V , the upper journal and bearing may be designed.

235. **Jib.**—The forces acting on the jib are, first, AB acting vertically downward at its end; second, an upward reaction

* See Force Diagram, Fig. 266.

from the brace at H , whose line of action coincides with the axis of the brace; * third, a downward reaction at L where the jib joins the mast, whose line of action must coincide with the line of action of the resultant of AB and the brace reaction. LK is therefore this line of action.

FIG. 267.

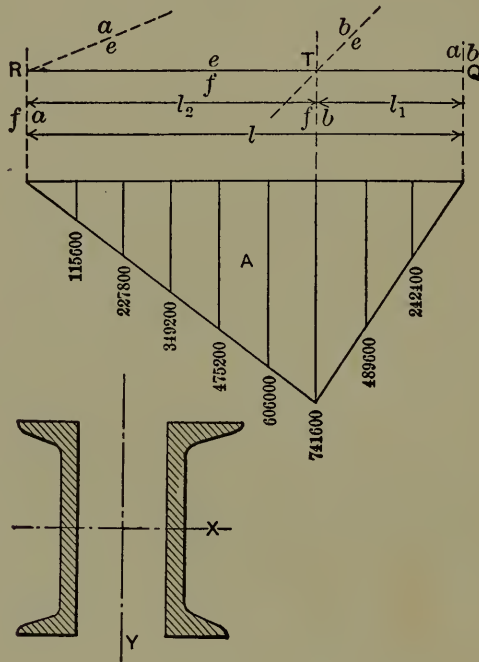

FIG. 268.

In the force diagram draw BE parallel to the center line of the brace, and draw EA parallel to LK . Then BE will represent the brace reaction, and EA will represent the reaction at L in the line ae . Let RQ , Fig. 267, represent the jib isolated. ae , be , and ab are the lines of action of the three forces acting upon it. The vertical components of these forces are in equilibrium, and tend to produce flexure in the jib. The horizontal components are in equilibrium and tend to produce tension in the jib. The vertical

* Considering the joint between the brace and jib equivalent to a pin connection.

force acting at R is FA ,* = 5000 lbs., the vertical force acting at T is FB , = 15,000 lbs., and the vertical force acting at Q is AB , = 10,000 lbs.

Flexure is also produced in the jib by its own weight acting as a uniformly distributed load.

In order to design the jib, standard rolled forms may be selected which will afford convenient support for the sheave carriage. Two channels located as shown in Fig. 268 will serve for this crane. For trial 12-inch heavy channels are chosen. From Carnegie's Hand-book, the moment of inertia for each channel about an axis perpendicular to the web at the center = $I = 248$; $c = 6$ inches; the weight, w , of two channels per inch of length = $8\frac{1}{3}$ lbs.

The total weight of the two channels = $wl = 8\frac{1}{3} \times 18 \times 12 = 1800$ lbs. The vertical reaction, P_1 , at R , Fig. 267, due to this weight is $P_1 = \left(\frac{wl_2^2}{2} - \frac{wl_1^2}{2} \right) \div l_2$, from the equation of moments, due to the weight of jib about the point T . Introducing numerical values, $P_1 = 450$ lbs. The total reaction at R is therefore $5000 - 450 = 4550$ lbs. A diagram of moments of flexure may now be drawn under the jib, Fig. 267. Considering the portion TQ , the moment at $T = Pl_1 + \frac{wl_1^2}{2} = 741,600$ in.-lbs. Divide TQ into three equal parts. At the division nearest T the moment = $Pl_3 + \frac{wl_3^2}{2}$; in which l_3 = the distance from Q to the section considered. The moment at the other two points may be found by similar method.

The moment at any point at the left of $T = 4550 \times l_4 + \frac{wl_4^2}{2}$; in which l_4 is the distance from R to the section considered. From the values thus found the diagram of flexure moments may be

* See force diagram, Fig. 266.

drawn. The maximum value is at T , where $M = 741,600$ in.-lbs. The resulting fiber stress $= f = \frac{Mc}{I} = \frac{741600 \times 6}{248 \times 2} = 8971$ lbs. The horizontal component acting at R is equal to FE (see force diagram, Fig. 266) $= 12,000$ lbs. An equal and opposite horizontal force must act at T . Between T and Q there is no tensile stress due to the forces AB , BE , and AE .

FIG. 269.

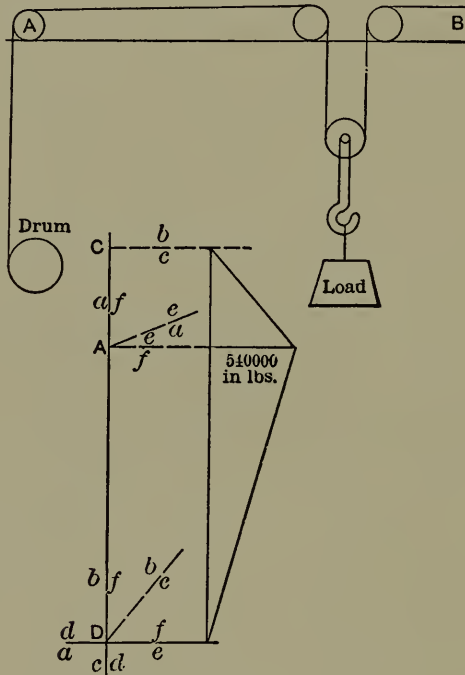

FIG. 270.

Another force which modifies this result needs to be considered. Let AB , Fig. 269, be the upper surface of the jib. The load is supported as shown. The chain which is fastened at B passes over the right-hand carriage sheave, down and under the hook sheave, up and over the left-hand carriage sheave, horizontally to the sheave at A , and thence to the winding drum. If a load of $10,000$ lbs. is supported by the hook there will be, neglecting friction, a tension of 5000 lbs. throughout the entire length of the

chain from B to the winding drum. There is therefore a force of 5000 lbs. tending to bring A and B nearer together, and hence to produce compression in the jib.* The resultant tension between R and T is $12,000 - 5000 = 7000$ lbs., while between T and Q there is a compression of 5000 lbs. The cross-sectional area of the two channels selected = 30 square inches. Hence the unit tensile stress = $f_1 = 7000 \div 30 = 233$ lbs. The maximum unit tensile stress in the jib = $f + f_1 = 8971 + 233 = 9204$ lbs. per square inch.

If the channels are of steel, their unit tensile strength will probably equal 60,000 lbs. per square inch. The factor of safety = $60,000 \div 9204 = 6.5$. In a crane a load may drop through a certain space by reason of the slipping of a link that has been caught up, or the failure of the support under the load while the chain is slack. When this occurs a blow is sustained by the stress members of the crane. The energy of this blow equals the load multiplied by the height of fall. But the stress members of the crane are long, and the yielding is large. Hence the space through which the blow is resisted is large and the resulting force is less than with small yielding. In other words, the stress members act as a spring, reducing the force due to shock. Hence, in a crane of this type, the ductile and resilient material is liable to modified shock, and a factor of safety = 6.5 is large enough.

The jib might also be checked for shear, but in general it will be found to have large excess of strength.

236. Mast.—Fig. 270 shows the mast by its center line with the lines of action of the forces acting upon it. It is equivalent to a beam supported at C and D with a load at A . The moment of flexure at A equals the force acting in the line bc † multiplied by the distance CA in inches, = $9000 \text{ lbs.} \times 60 \text{ inches} = 540,000$

* There is also flexure due to this force multiplied by the distance from the centre line of the horizontal chain to the gravity axis of the jib. This is small and may be neglected.

† The force BC in Fig. 266.

in.-lbs. = M . The flexure moment is a maximum at this point, and decreases uniformly toward both ends. The moment diagram is therefore as shown. The maximum fiber stress due to this flexure moment = $f = Mc \div I$. Selecting two light 12-inch channels, $I = 176$; $c = 6$ inches; $f = \frac{540000 \times 6}{2 \times 176} = 9200$ lbs.

The tension in the mast equals the vertical component of the force acting in the line ae ,* = 5000 lbs. (Actually reduced to 4550 by the effect of the weight of the jib.) The compression in the mast due to the tension in the chain = 5000 lbs. between A and the point of support of the winding drum B . The tension and compression therefore neutralize each other, except below B , where the flexure moment is small. Hence the maximum unit stress in the mast is 9200 lbs. The factor of safety = $60000 \div 9200 = 6.5$, which is safe as before. This also may be checked for shear.

237. Brace.—The compression stress in the brace is 19,000 lbs.,† and the length, 19 feet, is such that it needs to be treated as a “long column.” Because of the yielding of joints and of the other stress members, the brace is intermediate between a member with “hinged ends” and “flat ends”; therefore for safety it should be considered as hinged. In the treatment of long columns, the “straight-line formula” will be used.‡ This formula is of the form

$$\frac{P}{A} = p = B - C \frac{l}{r}$$

P is the total force that will cause incipient buckling, and hence the force that will destroy the column; A is the cross-sectional area of the column; p is the unit stress that will cause buckling;

* The force AE in Fig. 256.

† See force diagram, Fig. 266.

‡ For discussion of long-column formulæ see “Theory and Practice of Modern Framed Structures,” by Johnson, Bryan, and Turneaure, page 143. Published by John Wiley & Sons.

B and C are constants derived from experiments on long columns (the values of B and C vary with the method of attachment of the ends of the column, and with the material of the column); l is the length of the column in inches; and r is the radius of gyration of the cross-section, $=\sqrt{I \div A}$, I being the moment of inertia of the cross-section referred to the axis about which buckling takes place.

Values of B and C are as follows:

$$\text{For wrought iron, hinged ends, } \frac{P}{A} = 42000 - 157 \frac{l}{r}.$$

$$\text{“ “ “ flat “ } \frac{P}{A} = 42000 - 128 \frac{l}{r}.$$

$$\text{“ mild steel, hinged “ } \frac{P}{A} = 52500 - 220 \frac{l}{r}.$$

$$\text{“ “ “ flat “ } \frac{P}{A} = 52500 - 179 \frac{l}{r}.$$

The brace will be of mild steel channels, and the ends will be considered as hinged. The formula to be used is therefore

$$\frac{P}{A} = 52500 - 220 \frac{l}{r},$$

from which

$$P = \left(52500 - 220 \frac{l}{r} \right) A.$$

Channel bars may be selected and values of r and A become known from tables. For trial 5-inch light channels are chosen. Carnegie's tables give for 2 channels, $r = 3.8$ inches, and $A = 3.9$ square inches. Introducing these values in the above equation, with $l = 19' \times 12 = 228''$, gives $P = 153,270$ lbs. Since the maximum compression force sustained by the brace = 19,000 lbs.,

the factor of safety = $153,270 \div 19000 = 8+$. This is a larger value than those for the jib and mast, but it is probably inadvisable to use smaller channels because of convenience in making the connection with the jib and mast.

But the brace must be made safe against side buckling. The two channels may be considered as acting as a single member if they are braced laterally. The lateral bracing will be determined later. In Fig. 271 the moment of inertia about the axis X for

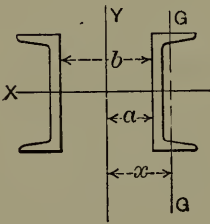

FIG. 271.

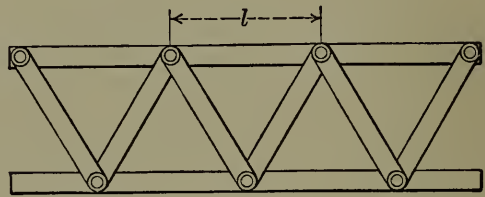

FIG. 272

each channel = 7 (from table.) If the moment of inertia of each about the axis Y be made = 7, the radius of gyration will be the same about both axes, the values in the above equation will be the same, and there will be the same safety against side buckling as against buckling in the plane through the axis of the mast. Therefore it is only necessary to make the distance, a , of each channel from the axis of Y such that $I_Y = 7$. The moment of inertia of one channel about its own gravity axis $GG = 0.466$. Its moment of inertia about $Y = 7 = I_G + Ax^2$. Solving, $x^2 = (I_Y - I_G) \div A$, whence

$$x^2 = \frac{7 - 0.466}{1.95} = 3.35,$$

$$x = 1.828.$$

Hence the distance apart of the gravity axes = $1.828 \times 2 = 3.65$. But the gravity axis is 0.44 inch from the face of the web, *i.e.*, $x - a = 0.44$. Therefore the distance, b , between the channels = $3.65 - 0.88 = 2.77$ inches. Convenience in construction would

undoubtedly dictate a greater distance, and hence greater safety against side buckling.

The position of these two channels relative to each other must be insured by some such means as diagonal bracing. See Fig. 272. The distance, l , must be such that the channels shall not buckle separately under half the total load. Solving the long-column formula gives

$$l = \left(52500 - \frac{P}{A} \right) \frac{r}{220},$$

in which P is the load sustained by each channel ($= 19000 \div 2 = 9500$ lbs.) multiplied by the factor of safety, say 6. The radius of gyration, r , is about a gravity axis parallel to the web, $= \sqrt{I \div A} = \sqrt{0.466 \div 1.95} = 0.488$.

$$l = \left(52500 - \frac{9500 \times 6}{1.95} \right) \frac{0.488}{220} = 51.8.$$

The value of l , therefore, must not be greater than 51.8 inches but it may be less if convenience, or the use of standard braces requires.

238. Crane Frame with Tension Rods.—The brace in the crane just considered may be replaced by tension rods, as shown in Fig. 273. This allows the load to be moved radially throughout the entire length of the jib. The force polygon, Fig. 274, shows tension equal to 37,000 lbs. in the tension rods, and compression in the jib = 35,800 lbs. If the tension rods are made of mild steel with an ultimate tensile strength of 60,000 lbs., and a factor of safety = 6, the cross-sectional area must equal $37,000 \times 6 \div 60,000 = 3.7$ square inches. If two rods are used the minimum diameter of each = 1.535; say, $1\frac{9}{16}$ inches.

The mast is a flexure member 20 feet long supported at the ends, and sustaining a transverse force of 35,800 lbs. at a distance of 5 feet from the upper end. The upper end reaction is there-

Compression in jib due to chain tension = 10,000 lbs.;

Compression in jib due to load = 35,800 lbs.;

Combined compression due to both = 10,000 \times 35,800 = 45,800 lbs.

Unit compression = combined compression \div area of the two channels = $\frac{45800}{30} = 1526$ lbs.

Maximum fiber stress due to combined flexure and compression = 7120 + 1526 = 8647 lbs. The factor of safety = $\frac{60000}{8646} = 6.96$. If a smaller factor of safety were desired, smaller channels could be used. The jib may be checked for shear.

The load might be moved nearly up to the mast, hence the joint at *F* must be designed for a total shear of 10,000 lbs. The pin and bearing at *G*, as well as the supporting framework for the bearing must be capable of sustaining a lateral force = *BC* = 8950 lbs. in any direction. The pivot and step at *H* must be capable of sustaining the lateral force *AD* = 8950 lbs., as well as a vertical downward thrust of 10,000 lbs. + the weight of the crane.

239. Pillar-crane Frame.—Fig. 275 shows an outline of the frame of a pillar crane. *HN* represents the floor level; *HK* represents the pillar, which is extended for support to *L*; *KM* represents one or more tension rods; *MH* represents the brace. The load hangs from *M* in the line *ab*. The pillar is supported horizontally at *H*, and vertically and horizontally at *L*. The force polygon shows the horizontal forces at *H* and *L* = 30,000 lbs., and the vertical force at *L* = 10,000 lbs. From these the supports may be designed. These supports should provide for rotary motion of the crane about *KL*, the axis of the pillar. The brace may be treated as in the jib crane, the compressive force being 21,400 lbs. The tension rods may be designed for the force 15,800 lbs.

The forces sustained by the pillar are as follows (see Fig. 276): *FE*, the horizontal component of *AE*, = 15,000 lbs., acts

in any horizontal cross-section may be found from the diagram *EFG*. Any section of the frame or stake may therefore be checked. The stake needs to be small as possible in order that small boiler shells and large flues may be riveted. In order that it may be of equal strength, with the cast iron frame, it is made of material of greater unit strength, as cast steel.

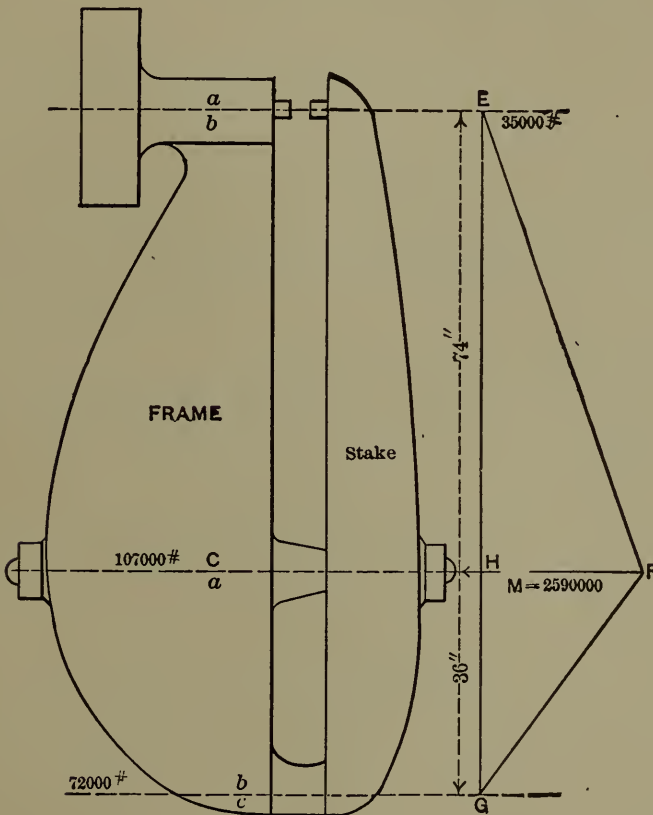

FIG. 277.

The two bolts which hold the frame and stake together sustain a force of 107,000 lbs. The force upon each therefore is 53,500 lbs. If the unit strength of the material is 50,000 lbs., and the factor of safety is 6, the area of cross-section of each bolt would be $= \frac{6 \times 53500}{50000} = 6.42$ square inches. The diameter corresponding $= 2.86$ inches. A $3\frac{1}{4}$ -inch bolt has a diameter at the

bottom of the thread = 2.88 inches, and hence $3\frac{1}{4}$ -inch bolts will serve as far as strength is concerned. But the body of the bolt is 60 inches long, and each inch of this length will yield a certain amount, and the total yielding might exceed an allowable value, even if a safe stress were not exceeded. The yielding per inch of length, or the *unit strain* = unit stress \div coefficient of elasticity, or

$$\lambda = \frac{f}{E}, \text{ but } f = \frac{P}{A} = \frac{53500}{8.3} = 6440 \text{ lbs.}$$

$$\text{and } E = 28,000,000$$

$$\therefore \lambda = \frac{6440}{28000000} = .00023 \text{ inch.}$$

Total yielding = $\lambda \times 60 = .00138$ inch.

This amount of yielding is allowable and therefore two $3\frac{1}{4}$ -inch bolts will serve.

APPENDIX.

THE following method of determining the position of the slider-crank chain corresponding to the maximum velocity of the slider is largely due to Professor L. M. Hoskins.

Refer to Fig. 278.

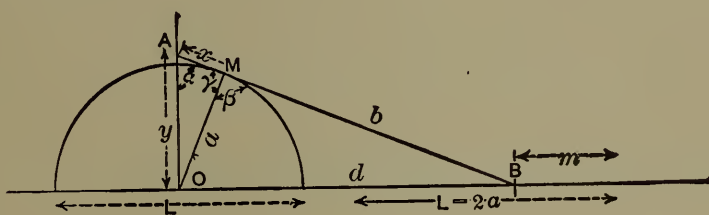

FIG. 278.

$BM = b =$ connecting-rod length, to scale.

$OM = a =$ crank length, to scale.

$OA = y$.

$AM = x$.

$OB = d$.

Angle $AOB = 90^\circ$.

“ $MAO = \alpha$.

“ $AMO = \gamma$.

“ $OMB = \beta$.

$L = 2a =$ length of stroke of slider.

From our study of the velocity diagram of the slider-crank chain (see § 22) we know that the length y will represent the

velocity of the slider on the same scale as the length a represents the velocity of the center of the crank-pin. The length y is determined by erecting at O a perpendicular to the line of action of the slider and cutting this perpendicular by the connecting-rod b , extended if necessary.

Our problem, then, is to find the position of the mechanism corresponding to the maximum value of y .

Consider the triangle whose sides are y , x , and a . Calling the angle included between x and y , α ,

$$a^2 = y^2 + x^2 - 2xy \cos \alpha; \quad \dots \dots \dots (1)$$

but $\cos \alpha = \frac{y}{x+b} \dots \dots \dots (2)$

$$\therefore a^2 = y^2 + x^2 - 2xy \frac{y}{x+b} \dots \dots \dots (3)$$

Clearing (3) of fractions and transposing,

$$\begin{aligned} 2xy^2 &= (x^2 + y^2 - a^2)(x+b), \\ 2xy^2 &= x^3 + x^2b + y^2x + y^2b - a^2x - a^2b. \quad \dots \dots (4) \end{aligned}$$

Differentiating,

$$2y^2 + 4xy \frac{dy}{dx} = 3x^2 + 2bx + y^2 + 2xy \frac{dy}{dx} + 2by \frac{dy}{dx} - a^2.$$

Transposing,

$$(4xy - 2xy - 2by) \frac{dy}{dx} = 3x^2 + 2bx + y^2 - a^2 - 2y^2. \quad \dots (5)$$

For maximum value of y , $\frac{dy}{dx} = 0$; hence we may write 0 for the left-hand term of (5).

$$0 = 3x^2 + 2bx + y^2 - a^2 - 2y^2;$$

$$\therefore y^2 = 3x^2 + 2bx - a^2. \dots \dots \dots (6)$$

Adding x^2 and subtracting a^2 from both sides of (6),

$$x^2 + y^2 - a^2 = 4x^2 + 2bx - 2a^2. \dots \dots \dots (7)$$

From (3),

$$x^2 + y^2 - a^2 = \frac{2xy^2}{x+b}.$$

Substituting this value in (7),

$$\frac{2xy^2}{x+b} = 4x^2 + 2bx - 2a^2;$$

$$\therefore 2xy^2 = (4x^2 + 2bx - 2a^2)(x+b). \dots \dots \dots (8)$$

Substituting in (8) the value of y^2 given in (6),

$$2x(3x^2 + 2bx - a^2) = (4x^2 + 2bx - 2a^2)(x+b);$$

$$\therefore 6x^3 + 4bx^2 - 2a^2x = 4x^3 + 4bx^2 + 2bx^2 + 2b^2x - 2a^2x - 2ba^2;$$

$$2x^3 - 2bx^2 - 2b^2x + 2ba^2 = 0;$$

$$x^3 - bx^2 - b^2x + ba^2 = 0. \dots \dots \dots (9)$$

Dividing (9) by a^3 and transposing,

$$\frac{a^2}{b^2} = \frac{x}{b} + \frac{x^2}{b^2} - \frac{x^3}{b^3}. \dots \dots \dots (10)$$

Equation (10) gives us the relation existing between a , b , and x for the maximum velocity of the slider.

By taking a series of values of $\frac{x}{b}$ and solving (10) for the corresponding values of $\frac{a}{b}$, Curve *A* has been constructed. Ordinates are $\frac{x}{b}$, abscissæ are $\frac{a}{b}$.

For any given problem the values of *a* and *b* are known. Solve for $\frac{a}{b}$.

From Curve *A* find the value of $\frac{x}{b}$ corresponding to this value of $\frac{a}{b}$.

From the determined value of $\frac{x}{b}$ and the known value of *b* the numerical value of *x* is found.

But equation (6) gives for the maximum value of *y* the relation

$$y^2 = 3x^2 + 2bx - a^2,$$

which we can readily solve for *y* since all of the right-hand terms are now known.

AOB being a right-angled triangle,

$$d^2 = (x + b)^2 - y^2.$$

The values of the right-hand member being known we can readily solve this for *d*.

Let *m* represent the distance moved through by the slider from the beginning of the stroke, then

$$m = b + a - d.$$

The portion of the stroke accomplished by the slider at the time of its maximum velocity expressed as a fraction of the whole stroke, $2a$,

$$= \frac{m}{2a}.$$

Curve *B* shows the relation between $\frac{a}{b}$ and $\frac{m}{2a}$. From this curve we can see at a glance for any given value of $\frac{a}{b}$ what per cent of the slider's stroke is accomplished when its position of maximum velocity is reached. Abscissæ are values of $\frac{a}{b}$; ordinates $\frac{m}{2a}$.

$\frac{y}{a}$ = ratio of the maximum velocity of the slider to the velocity of the center of the crank-pin. Curve *C* shows the relation between the values of $\frac{a}{b}$ and $\frac{y}{a}$. Abscissæ are values of $\frac{a}{b}$; ordinates $\frac{y}{a} - 1$. Add unity to the ordinates for actual values of $\frac{y}{a}$.

To find the values of β corresponding to the maximum velocity of the slider we have the three sides of the triangle *OMB*, namely, b , a , and d . Let

$$s = \frac{b + a + d}{2}.$$

Then $\cos \frac{1}{2}\beta = \frac{s(s-d)}{ba}$, from which we can readily get the value of β .

Curve *D* is plotted with values of β , in degrees, as ordinates and values of $\frac{a}{b}$ as abscissæ.

TABLE XXXI.—ASSUMED VALUES OF $\frac{x}{b}$, AND CORRESPONDING COMPUTED VALUES OF $\frac{a}{b}$, $\frac{y}{b}$, $\frac{m}{2a}$, $\frac{y}{a}$, AND β , TO PLOT CURVES A, B, C, AND D.

$\frac{x}{b}$	0.010	0.015	0.025	0.035	0.050	0.075	0.100	0.200
$\frac{a}{b}$	0.1005	0.1234	0.1600	0.1902	0.2289	0.2832	0.3302	0.4817
$\frac{y}{b}$	0.101	0.1243	0.1621	0.1936	0.2348	0.2944	0.3479	0.5367
$\frac{m}{2a}$	0.4751	0.4704	0.4622	0.4561	0.4484	0.4402	0.4320	0.4239
$\frac{y}{a}$	1.005	1.0073	1.0131	1.0179	1.0258	1.0395	1.0533	1.1139
β	89° 55'	89° 49'	89° 44'	89° 35'	89° 26'	88° 50'	88° 16'	85° 17'
$\frac{x}{b}$	0.300	0.400	0.500	0.600	0.700	0.800	0.900
$\frac{a}{b}$	0.6025	0.7043	0.7906	0.8626	0.9203	0.9633	0.9905
$\frac{y}{b}$	0.7121	0.8854	1.0607	1.2393	1.4223	1.6100	1.8025
$\frac{m}{2a}$	0.4273	0.4409	0.4597	0.4901	0.5374	0.6044	0.7221
$\frac{y}{a}$	1.1819	1.2571	1.3416	1.4367	1.5455	1.6713	1.8198
β	81° 23'	76° 41'	71° 33'	65° 19'	57° 50'	48° 21'	35° 8'

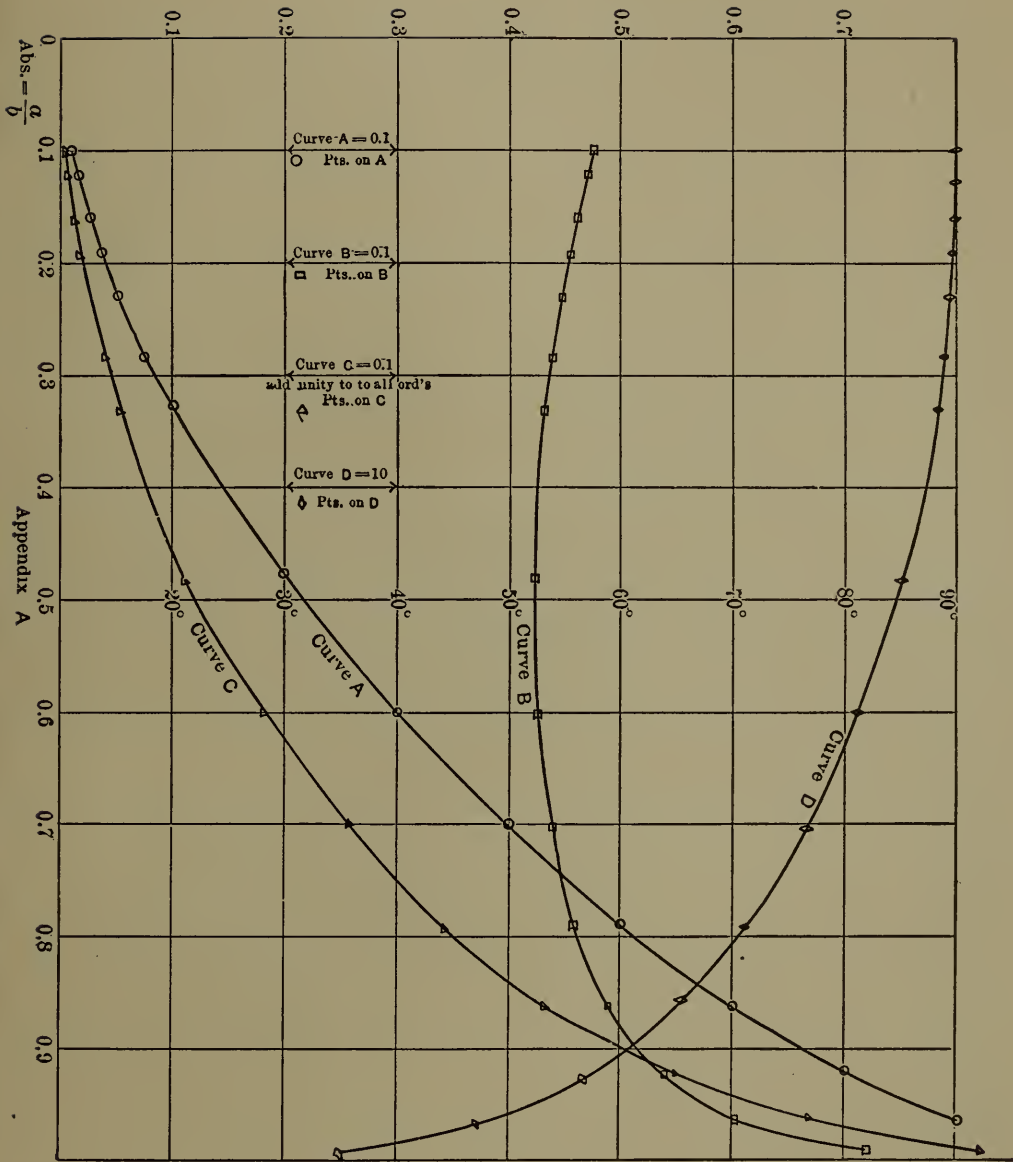

INDEX.

	PAGES
Acceleration, diagrams of.	55-63
Addendum.	263
Angle of action.	270-272, 273
Application, machinery of.	4
Arc of action.	270-272, 273
Axle design.	161-164
Axles, shafts, and spindles.	161-171
Backlash.	263
Ball-bearings, see Roller- and Ball-bearings.	
Bearing pressure, allowable for journals.	173-174
allowable for roller- and ball-bearings	206-207
allowable for sliding surfaces.	158-159
allowable for thrust-bearings.	186
Bearings.	188-192
See also Journals; Roller- and Ball-bearings.	
Belts.	218-243
cone pulley.	224-227
crowning pulleys.	224
design, theory of.	227-233
distance between shafts for.	239
driving capacity, variation of.	236-239
dynamo-belt design.	234-236
intersecting axes.	222-223
pump-belt design.	233-234
rope-drives.	239-243
shifting, principle of.	221
transmission of motion by.	218-221
twist.	221-222
weight of leather.	232
Bevel-gears.	290-297
Bolts and screws.	112-140
analysis of screw action.	115-118
calculation of bolts subject to elongation.	125-129

	PAGES
Bolts and screws, calculation of screws for transmission of power. . .	133-140
calculation of screws not stressed in screwing up. . .	118, 119
calculation of screws stressed in screwing up.	119-129
classification and definition.	112-115
design of bolts for shock.	129-132
jam-nuts.	132
U. S. standard threads.	113, 114
wrench-pull.	124
Boxes.	188-192
See also Journals.	
Box pillar, see Supports.	
Brackets.	80-81
See also Supports.	
Cams.	44-49
Cast-iron parts.	81-82
Centro.	10-12
location of.	15-16, 17, 19-22
Centrode.	12-13
Centros of three links.	16-17
Clearance.	263
Clutches.	213-217
See also Couplings.	
Connecting-rod, angularity of.	28, 29
Constrained motion.	4-8
Cotters.	147, 148
Couplings and clutches.	209-217
claw or toothed.	213-214
combination friction and claw.	217
compression.	210-211
flange.	210
flexible.	212-213
friction.	214-217
Hooke's.	212
Oldham's.	212
Sellers'.	211
sleeve or muff.	209
Weston friction.	216-217
Cranes, problems in design of.	338-350
Crank-pin, design of.	182
Cross-head pin, design of.	183
Cutting speeds.	30
Cycloidal gears.	267-270, 274, 276, 277, 291
Dynamo, belt design for.	234-236

	PAGES
Efficiency of machines.	2
Elements, pairs of motion.	13
size of.	17-18
Energy, definition of.	1
in machines.	50-66
law of conservation of.	1
sources of.	3
Feathers, see Keys.	
Fly-wheels.	244-260
construction of.	257-260
design, general method.	245
pump.	249-252
punching-machine.	245-249
steam-engine.	252
stresses in arms.	255-257
stresses in rims.	252-255
theory of.	244-245
Force, definition of.	1
Force-fits.	149-152
Frames.	77-80, 318-352
closed.	329-331
cranes.	338-350
open-side.	318-329
punching-machine.	318-324
riveting-machine.	350-352
slotting-machine.	324-326
steam-engine, center-crank.	329-331
steam-engine, side-crank.	326-329
steam-hammer.	332-338
See also Supports, and Machine parts.	
Friction, coefficient for belts.	232
coefficient for ropes.	240
clutches.	214-217
See also Journals, and Sliding surfaces.	
Gearing, see Toothed wheels or gears.	
Indicator mechanisms.	41-43
Crosby.	42-43
Tabor.	41
Thompson.	42
Involute gears.	272-274, 275, 276, 279, 292
Instantaneous center.	10-12
Instantaneous motion.	10

	PAGES
Jib-crane.	338-349
Journals.	172-197
allowable bearing pressure.	173-174
calculation of, for strength.	178
crank-pin of engine.	182
cross-head pin of engine.	183
general discussion.	172-173
heating of.	175-177
lubrication of.	192-197
main journal of engine.	179-181
materials for, and bearings.	177-178
proportions of.	177
thrust-.	184-188
Keys, classification of.	141
feathers.	145, 146
parallel.	141
round, taper.	147
saddle and flat.	145
splines.	145, 146
strength of.	145
taper.	141, 142
Woodruff.	144, 145
Lathe, bed.	80
supports.	314-317
Legs, see Supports.	
Lever-crank chain, location of centros.	17
velocity diagram.	26
Linear velocity.	22
points in different links.	26
Line-shafts.	168-171
Linkage.	14
Lubrication, of rollers and ball-bearings.	208
of rotating surfaces.	192-197
of sliding surfaces.	157-160
Machine cycle.	2
Machine frames, form dictated by stress.	77-80
See also Frames.	
Machine function defined.	2
Machine parts, forms of cast members.	81, 82
proportions of.	67-82

	PAGES
Main journal, design of.	179-181
Mechanism, definition of.	15
location of centros in compound.	19-22
Motion, chains.	14-15
constrained.	4-8
definition of.	1
free.	4
helical.	9
instantaneous.	10-13
kinds of, in machines.	8-9
plane.	8
relative.	9
spheric.	9
Pairs of elements.	13
Parallel motions, see Straight-line motions.	
Passive resistance.	5-8
Pillar crane.	349-350
Pitch arc.	270
Pitch circle.	262
Pitch, circular.	263
diametral.	263
Planing-machine, bed.	79-80, 313, 317
lubrication of.	160
table.	78-79
Prime mover.	3
Pulleys, cone.	224-227
crowning.	224
idler or guide.	223
proper size of.	239
stresses in arms.	255-257
stresses in rims.	252-255
See also Fly-wheels.	
Pump, belt design for.	233-234
fly-wheel design.	249-252
Punching-machine, fly-wheel design.	245-249
frame design.	318-324
Quick-return mechanisms.	30-38
lever-crank quick-return.	32-35
slider-crank quick-return.	30-32
Whitworth quick-return.	35-3
Rigid body.	10

	PAGES
Riveted joints.	83-111
boiler-shell problem.	105-111
construction for tightness.	101, 102
counter-sunk rivets.	101
efficiencies of various kinds of.	90-97, 99
failure of.	87, 88
general formulæ.	97, 95
kinds of.	86, 87
length of rivet.	100
margin.	98
methods of riveting.	83, 84
more than two plates.	103, 104
nickel-steel rivets.	101
perforations of plate.	84, 85
plates not in same plane.	104, 105
plates with upset edges.	102
slippage.	99
strength of materials used.	88, 99, 102
strength, proportions, and efficiency of.	90-97, 99
Riveting-machine, action of.	84
frame design.	350, 352
Roller- and ball-bearings.	198-208
allowable loading.	206-207
form of races.	201-206
lubrication and sealing.	208
rolling, sliding, and spinning.	198-205
size of.	207
Rope transmission.	239-243
Screws, see Bolts and screws.	
Screw-threads, see Bolts and screws.	
Set-screws.	113, 115, 148
Shafting, angular distortion.	167
combined thrust and torsion.	167-168
combined torsion and bending.	165-166
hollow vs. solid.	166-167
line-shafts.	168-171
simple torsion.	164-165
Shaping-machine, force problem.	52-54
Sheave-wheels, angle of groove.	242
diameter of.	240
Shrink-fits.	149-152
Skew bevel-gears.	297
Slider-crank chain, acceleration diagrams.	55-63
description of.	19

	PAGES
Slider-crank chain, force problem, shaping-machine.	52-54
force problems, steam-engine.	54-66
location of centros.	15-16
maximum velocity of slider.	353-358
tangential effort diagrams.	64-66
velocity diagram.	24-26
Sliding surfaces.	153-160
allowable bearing pressure.	158-159
form of guides.	155-157
general discussion.	153
lubrication of.	157-165
proportions dictated by wear.	154, 155
Slotted cross-head.	18-19
Slotting-machine, frame design.	324-326
Spindles, see Axles, shafts, and spindles.	
Spiral gears.	297-305
Splines, see Keys.	
Springs.	308-312
cantilever.	309-311
coil or spiral.	311-312
leaf.	310-311
Spur-gears.	261-290, 305-307
Steam-engine, boxes.	190
crank-pin.	174, 177, 182
cross-head pin.	174, 177, 183
fly-wheel design.	252
force problems.	54-66
frame, center-crank.	229-331
frame, "girder bed".	326-328
frame, "heavy duty".	328-329
main journal.	174, 177, 179-181
Steam-hammer, double-acting, frame design.	336-338
single-acting, frame design.	332-336, 337
Straight-line motions.	39-43
general method of design.	41-43
grasshopper motion.	40, 41
parallelogram.	39, 40
Watt parallel motion.	39
Stresses in machine parts, compression.	74, 75
constant.	68
flexure.	75, 76
shock.	73, 74
tension.	74
torsion.	76, 77
variable.	69-73

	PAGES
Supports.	313-317
divided.	314-315
general laws for design of.	313
reduced number of.	316-317
three-point	315-316
See also Brackets, and Frames.	
Thrust-journals.	184-188
Toothed wheels or gears.	261-307
addendum.	263
angle of action.	270-272
annular.	276
arc of action.	270, 272
backlash.	263
bevel-gears.	290-297
circular pitch.	263
clearance.	263
cycloidal teeth.	267-270, 274, 276, 277, 291
depth, total.	263
depth, working.	263
diametral pitch.	263
forms of teeth.	264-270, 272-274, 280-283
interchangeable sets.	277-280
involute teeth.	272-274, 275, 276, 279, 297
line of pressure.	270
non-circular wheels.	289-290
pinion.	274
pitch arc.	270
pitch circle.	262
proportions of.	283-284
racks.	274, 275
skew bevel-gears.	297
spiral gears.	297-305
spur-gear chains, compound.	305-307
spur-wheels.	261-290
strength of teeth.	285-289, 295, 304
theory of.	260-261
worms and wheels.	298-305
Torque diagrams.	64-66
Transmission, machinery of.	3
See also Belts, Rope, and Toothed wheels.	
Vector quantity.	23
Velocity, angular.	22

INDEX.

369

	PAGES
Velocity, linear.	22
relative.	22, 24, 26-27
Whitworth quick-return mechanism.	35-36
Work, definition of.	I
Worm-gearing.	297-305

SHORT-TITLE CATALOGUE

OF THE
PUBLICATIONS

OF
JOHN WILEY & SONS,

NEW YORK.

LONDON: CHAPMAN & HALL, LIMITED.

ARRANGED UNDER SUBJECTS.

Descriptive circulars sent on application. Books marked with an asterisk (*) are sold at *net* prices only, a double asterisk (**) books sold under the rules of the American Publishers' Association at *net* prices subject to an extra charge for postage. All books are bound in cloth unless otherwise stated.

AGRICULTURE.

Armsby's Manual of Cattle-feeding.	12mo,	\$1 75
Principles of Animal Nutrition.	8vo,	4 00
Budd and Hansen's American Horticultural Manual:		
Part I. Propagation, Culture, and Improvement.	12mo,	1 50
Part II. Systematic Pomology.	12mo,	1 50
Downing's Fruits and Fruit-trees of America	8vo,	5 00
Elliott's Engineering for Land Drainage.	12mo,	1 50
Practical Farm Drainage.	12mo,	1 00
Green's Principles of American Forestry.	12mo,	1 50
Grottenfelt's Principles of Modern Dairy Practice. (Woll.).	12mo,	2 00
Kemp's Landscape Gardening.	12mo,	2 50
Maynard's Landscape Gardening as Applied to Home Decoration.	12mo,	1 50
Sanderson's Insects Injurious to Staple Crops.	12mo,	1 50
Insects Injurious to Garden Crops. (In preparation.)		
Insects Injuring Fruits. (In preparation.)		
Stockbridge's Rocks and Soils.	8vo,	2 50
Woll's Handbook for Farmers and Dairymen.	16mo,	1 50

ARCHITECTURE.

Baldwin's Steam Heating for Buildings.	12mo,	2 50
Bashore's Sanitation of a Country House.	12mo,	1 00
Berg's Buildings and Structures of American Railroads.	4to,	5 00
Birkmire's Planning and Construction of American Theatres.	8vo,	3 00
Architectural Iron and Steel.	8vo,	3 50
Compound Riveted Girders as Applied in Buildings.	8vo,	2 00
Planning and Construction of High Office Buildings.	8vo,	3 50
Skeleton Construction in Buildings.	8vo,	3 00
Brigg's Modern American School Buildings.	8vo,	4 00
Carpenter's Heating and Ventilating of Buildings.	8vo,	4 00
Freitag's Architectural Engineering.	8vo,	3 50
Fireproofing of Steel Buildings.	8vo,	2 50
French and Ives's Stereotomy.	8vo,	2 50
Gerhard's Guide to Sanitary House-inspection.	16mo,	1 00
Theatre Fires and Panics.	12mo,	1 50
Holly's Carpenters' and Joiners' Handbook.	18mo,	75
Johnson's Statics by Algebraic and Graphic Methods.	8vo,	2 07

Kidder's Architects' and Builders' Pocket-book. Rewritten Edition.	16mo, mor.,	5 00
Merrill's Stones for Building and Decoration.	8vo,	5 00
Non-metallic Minerals: Their Occurrence and Uses.	8vo,	4 00
Monckton's Stair-building.	4to,	4 00
Patton's Practical Treatise on Foundations.	8vo,	5 00
Peabody's Naval Architecture.	8vo,	7 50
Richey's Handbook for Superintendents of Construction.	16mo, mor ,	4 00
Sabin's Industrial and Artistic Technology of Paints and Varnish.	8vo,	3 00
Siebert and Biggin's Modern Stone-cutting and Masonry.	8vo,	1 50
Snow's Principal Species of Wood.	8vo,	3 50
Sondericker's Graphic Statics with Applications to Trusses, Beams, and Arches.	8vo,	2 3
Towne's Locks and Builders' Hardware.	18mo, morocco,	3 00
Wait's Engineering and Architectural Jurisprudence.	8vo,	6 00
	Sheep,	6 50
Law of Operations Preliminary to Construction in Engineering and Architecture.	8vo,	5 00
	Sheep,	5 50
Law of Contracts.	8vo,	3 00
Wood's Rustless Coatings: Corrosion and Electrolysis of Iron and Steel.	8vo,	4 00
Woodbury's Fire Protection of Mills.	8vo,	2 50
Worcester and Atkinson's Small Hospitals, Establishment and Maintenance, Suggestions for Hospital Architecture, with Plans for a Small Hospital.	12mo,	1 25
The World's Columbian Exposition of 1893.	Large 4to,	1 00

ARMY AND NAVY.

Bernadou's Smokeless Powder, Nitro-cellulose, and the Theory of the Cellulose Molecule.	12mo,	2 50
* Bruff's Text-book Ordnance and Gunnery.	8vo,	6 00
Chase's Screw Propellers and Marine Propulsion.	8vo,	3 00
Cloke's Gunner's Examiner.	8vo,	1 50
Crag's Azimuth.	4to,	3 50
Crehore and Squier's Polarizing Photo-chronograph.	8vo,	3 00
Cronkhite's Gunnery for Non-commissioned Officers.	24mo, morocco,	2 00
* Davis's Elements of Law.	8vo,	2 50
* Treatise on the Military Law of United States.	8vo,	7 00
	Sheep,	7 50
De Brack's Cavalry Outposts Duties. (Carr.)	24mo, morocco,	2 00
Dietz's Soldier's First Aid Handbook.	16mo, morocco,	1 25
* Dredge's Modern French Artillery.	4to, half morocco,	15 00
Durand's Resistance and Propulsion of Ships.	8vo,	5 00
* Dyer's Handbook of Light Artillery.	12mo,	3 00
Eissler's Modern High Explosives.	8vo,	4 00
* Fiebeger's Text-book on Field Fortification.	Small 8vo,	2 00
Hamilton's The Gunner's Catechism.	18mo,	1 00
* Hoff's Elementary Naval Tactics.	8vo,	1 50
Ingalls's Handbook of Problems in Direct Fire.	8vo,	4 00
* Ballistic Tables.	8vo,	1 50
* Lyons's Treatise on Electromagnetic Phenomena. Vols. I. and II.	8vo, each,	6 00
* Mahan's Permanent Fortifications. (Mercur.)	8vo, half morocco,	7 50
Manual for Courts-martial.	16mo, morocco,	1 50
* Mercur's Attack of Fortified Places.	12mo,	2 00
* Elements of the Art of War.	8vo,	4 00
Metcalf's Cost of Manufactures—And the Administration of Workshops.	8vo,	5 00
* Ordnance and Gunnery. 2 vols.	12mo,	5 00
Murray's Infantry Drill Regulations.	18mo, paper,	10
Nixon's Adjutants' Manual.	24mo,	1 00
Peabody's Naval Architecture.	8vo,	7 50

* Phelps's Practical Marine Surveying.	8vo,	2 50
Powell's Army Officer's Examiner.	12mo,	4 00
Sharpe's Art of Subsisting Armies in War.	18mo, morocco,	1 50
* Walke's Lectures on Explosives.	8vo,	4 00
* Wheeler's Siege Operations and Military Mining.	8vo,	2 00
Winthrop's Abridgment of Military Law.	12mo,	2 50
Woodhull's Notes on Military Hygiene.	16mo,	1 50
Young's Simple Elements of Navigation.	16mo, morocco,	1 00
Second Edition, Enlarged and Revised.	16mo, morocco,	2 00

ASSAYING.

Fletcher's Practical Instructions in Quantitative Assaying with the Blowpipe.	12mo, morocco,	1 50
Furman's Manual of Practical Assaying.	8vo,	3 00
Lodge's Notes on Assaying and Metallurgical Laboratory Experiments.	8vo,	3 00
Miller's Manual of Assaying.	12mo,	1 00
O'Driscoli's Notes on the Treatment of Gold Ores.	8vo,	2 00
Ricketts and Miller's Notes on Assaying.	8vo,	3 00
Ulke's Modern Electrolytic Copper Refining.	8vo,	3 00
Wilson's Cyanide Processes.	12mo,	1 50
Chlorination Process.	12mo,	1 50

ASTRONOMY.

Comstock's Field Astronomy for Engineers.	8vo,	2 50
Craig's Azimuth.	4to,	3 50
Doolittle's Treatise on Practical Astronomy.	8vo,	4 00
Gore's Elements of Geodesy.	8vo,	2 50
Hayford's Text-book of Geodetic Astronomy.	8vo,	3 00
Merriman's Elements of Precise Surveying and Geodesy.	8vo,	2 50
* Michie and Harlow's Practical Astronomy.	8vo,	3 00
* White's Elements of Theoretical and Descriptive Astronomy.	12mo,	2 00

BOTANY.

Davenport's Statistical Methods, with Special Reference to Biological Variation.	16mo, morocco,	1 25
Thomé and Bennett's Structural and Physiological Botany.	16mo,	2 25
Westermaier's Compendium of General Botany. (Schneider).	8vo,	2 00

CHEMISTRY.

Adriance's Laboratory Calculations and Specific Gravity Tables.	12mo,	1 25
Allen's Tables for Iron Analysis.	8vo,	3 00
Arnold's Compendium of Chemistry. (Mandel).	Small 8vo,	3 50
Austen's Notes for Chemical Students.	12mo,	1 50
Bernadou's Smokeless Powder,—Nitro-cellulose, and Theory of the Cellulose Molecule.	12mo,	2 50
Bolton's Quantitative Analysis.	8vo,	1 50
* Browning's Introduction to the Rarer Elements.	8vo,	1 50
Brush and Penfield's Manual of Determinative Mineralogy.	8vo,	4 00
Classen's Quantitative Chemical Analysis by Electrolysis. (Boltwood).	8vo,	3 00
Cohn's Indicators and Test-papers.	12mo,	2 00
Tests and Reagents.	8vo,	3 00
Crafts's Short Course in Qualitative Chemical Analysis. (Schaeffer).	12mo,	1 50
Dolezalek's Theory of the Lead Accumulator (Storage Battery). (Von Ende).	12mo,	2 50
Drechsel's Chemical Reactions. (Merrill).	12mo,	1 25
Duhem's Thermodynamics and Chemistry. (Burgess).	8vo,	4 00
Eissler's Modern High Explosives.	8vo,	4 00
Effront's Enzymes and their Applications. (Prescott).	8vo,	3 00
Erdmann's Introduction to Chemical Preparations. (Dunlap).	12mo,	1 25

Fletcher's Practical Instructions in Quantitative Assaying with the Blowpipe.	12mo, morocco,	1 50
Fowler's Sewage Works Analyses.	12mo,	2 00
Fresenius's Manual of Qualitative Chemical Analysis. (Wells.)	8vo,	5 00
Manual of Qualitative Chemical Analysis. Part I. Descriptive. (Wells.)	8vo,	3 00
System of Instruction in Quantitative Chemical Analysis. (Cohn.)	2 vols. 8vo,	12 50
Fuertes's Water and Public Health.	12mo,	1 50
Furman's Manual of Practical Assaying.	8vo,	3 00
* Getman's Exercises in Physical Chemistry.	12mo,	2 00
Gill's Gas and Fuel Analysis for Engineers.	12mo,	1 25
Grotenfelt's Principles of Modern Dairy Practice. (Woll.)	12mo,	2 00
Hammarsten's Text-book of Physiological Chemistry. (Mandel.)	8vo,	4 00
Helm's Principles of Mathematical Chemistry. (Morgan.)	12mo,	1 50
Hering's Ready Reference Tables (Conversion Factors).	16mo morocco,	2 50
Hind's Inorganic Chemistry.	8vo,	3 00
* Laboratory Manual for Students	12mo,	1 00
Holleman's Text-book of Inorganic Chemistry. (Cooper.)	8vo,	2 50
Text-book of Organic Chemistry. (Walker and Mott.)	8vo,	2 50
* Laboratory Manual of Organic Chemistry. (Walker.)	12mo,	1 00
Hopkins's Oil-chemists' Handbook.	8vo,	3 00
Jackson's Directions for Laboratory Work in Physiological Chemistry.	8vo,	1 25
Keep's Cast Iron.	8vo,	2 50
Ladd's Manual of Quantitative Chemical Analysis.	12mo,	1 00
Landauer's Spectrum Analysis. (Tingle.)	8vo,	3 00
* Langworthy and Austen. The Occurrence of Aluminium in Vegetable Products, Animal Products, and Natural Waters.	8vo,	2 00
Lassar-Cohn's Practical Urinary Analysis. (Lorenz.)	12mo,	1 00
Application of Some General Reactions to Investigations in Organic Chemistry. (Tingle.)	12mo,	1 00
Leach's The Inspection and Analysis of Food with Special Reference to State Control.	8vo,	7 50
Löb's Electrolysis and Electrosynthesis of Organic Compounds. (Lorenz.)	12mo,	1 00
Lodge's Notes on Assaying and Metallurgical Laboratory Experiments.	8vo,	3 00
Lunge's Techno-chemical Analysis. (Cohn.)	12mo,	1 00
Mandel's Handbook for Bio-chemical Laboratory	12mo,	1 50
* Martin's Laboratory Guide to Qualitative Analysis with the Blowpipe.	12mo,	60
Mason's Water-supply. (Considered Principally from a Sanitary Standpoint.)		
3d Edition, Rewritten.	8vo,	4 00
Examination of Water. (Chemical and Bacteriological.)	12mo,	1 25
Matthew's The Textile Fibres.	8vo,	3 50
Meyer's Determination of Radicles in Carbon Compounds. (Tingle.)	12mo,	1 00
Miller's Manual of Assaying.	12mo,	1 00
Mixter's Elementary Text-book of Chemistry.	12mo,	1 50
Morgan's Outline of Theory of Solution and its Results	12mo,	1 00
Elements of Physical Chemistry.	12mo,	2 00
Morse's Calculations used in Cane-sugar Factories.	16mo, morocco,	1 50
Mulliken's General Method for the Identification of Pure Organic Compounds.		
Vol. I.	Large 8vo,	5 00
O'Brine's Laboratory Guide in Chemical Analysis.	8vo,	2 00
O'Driscoll's Notes on the Treatment of Gold Ores.	8vo,	2 00
Ostwald's Conversations on Chemistry. Part One. (Ramsey.)	12mo,	1 50
Ostwald's Conversations on Chemistry. Part Two. (Turnbull.) (In Press.)		
* Penfield's Notes on Determinative Mineralogy and Record of Mineral Tests.	8vo, paper,	50
Pictet's The Alkaloids and their Chemical Constitution. (Biddle.)	8vo,	5 00
Pinner's Introduction to Organic Chemistry. (Austen.)	12mo,	1 50
Poole's Calorific Power of Fuels.	8vo,	3 00
Prescott and Winslow's Elements of Water Bacteriology, with Special Reference to Sanitary Water Analysis.	12mo,	1 25

* Reisig's Guide to Piece-dyeing.	8vo,	25 00
Richards and Woodman's Air, Water, and Food from a Sanitary Standpoint	8vo,	2 00
Richards's Cost of Living as Modified by Sanitary Science.	12mo,	1 00
Cost of Food, a Study in Dieteries	12mo,	1 00
* Richards and Williams's The Dietary Computer.	8vo,	1 50
Ricketts and Russell's Skeleton Notes upon Inorganic Chemistry. (Part I. Non-metallic Elements.)	8vo, morocco,	75
Ricketts and Miller's Notes on Assaying.	8vo,	3 00
Rideal's Sewage and the Bacterial Purification of Sewage.	8vo,	3 50
Disinfection and the Preservation of Food.	8vo,	4 00
Rigg's Elementary Manual for the Chemical Laboratory.	8vo,	1 25
Rostoski's Serum Diagnosis. (Bolduan.)	12mo,	1 00
Ruddiman's Incompatibilities in Prescriptions.	8vo,	2 00
Sabin's Industrial and Artistic Technology of Paints and Varnish.	8vo,	3 00
Salkowski's Physiological and Pathological Chemistry. (Orndorff.)	8vo,	2 50
Schimpf's Text-book of Volumetric Analysis.	12mo,	2 50
Essentials of Volumetric Analysis.	12mo,	1 25
Spencer's Handbook for Chemists of Beet-sugar Houses.	16mo, morocco,	3 00
Handbook for Sugar Manufacturers and their Chemists.	16mo, morocco,	2 00
Stockbridge's Rocks and Soils.	8vo,	2 50
* Tillman's Elementary Lessons in Heat.	8vo,	1 50
* Descriptive General Chemistry.	8vo,	3 00
Treadwell's Qualitative Analysis. (Hall.)	8vo,	3 00
Quantitative Analysis. (Hall.)	8vo,	4 00
Turneure and Russell's Public Water-supplies.	8vo,	5 00
Van Deventer's Physical Chemistry for Beginners. (Boltwood.)	12mo,	1 50
* Walke's Lectures on Explosives.	8vo,	4 00
Washington's Manual of the Chemical Analysis of Rocks.	8vo,	2 00
Wassermann's Immune Sera: Hæmolysins, Cytotoxins, and Precipitins. (Bolduan.)	12mo,	1 00
Well's Laboratory Guide in Qualitative Chemical Analysis.	8vo,	1 50
Short Course in Inorganic Qualitative Chemical Analysis for Engineering Students.	12mo,	1 50
Text-book of Chemical Arithmetic	12mo,	1 25
Whipple's Microscopy of Drinking-water.	8vo,	3 50
Wilson's Cyanide Processes	12mo,	1 50
Chlorination Process.	12mo,	1 50
Wulling's Elementary Course in Inorganic, Pharmaceutical, and Medical Chemistry.	12mo,	2 00

CIVIL ENGINEERING.

BRIDGES AND ROOFS. HYDRAULICS. MATERIALS OF ENGINEERING. RAILWAY ENGINEERING.

Baker's Engineers' Surveying Instruments.	12mo,	3 00
Bixby's Graphical Computing Table.	Paper 19 $\frac{1}{4}$ × 24 $\frac{1}{4}$ inches.	25
** Burr's Ancient and Modern Engineering and the Isthmian Canal. (Postage, 27 cents additional.)	8vo,	3 50
Comstock's Field Astronomy for Engineers.	8vo,	2 50
Davis's Elevation and Stadia Tables.	8vo,	1 00
Elliott's Engineering for Land Drainage.	12mo,	1 50
Practical Farm Drainage.	12mo,	1 00
*Fieberger's Treatise on Civil Engineering.	8vo,	5 00
Folwell's Sewerage. (Designing and Maintenance.)	8vo,	3 00
Freitag's Architectural Engineering. 2d Edition, Rewritten	8vo,	3 50
French and Ives's Stereotomy.	8vo,	2 50
Goodhue's Municipal Improvements.	12mo,	1 75
Goodrich's Economic Disposal of Towns' Refuse.	8vo,	3 50
Gore's Elements of Geodesy.	8vo,	2 50
Hayford's Text-book of Geodetic Astronomy.	8vo,	3 00
Hering's Ready Reference Tables (Conversion Factors).	16mo, morocco,	2 50

Howe's Retaining Walls for Earth.	12mo,	1 25
Johnson's (J. B.) Theory and Practice of Surveying.	Small 8vo,	4 00
Johnson's (L. J.) Statics by Algebraic and Graphic Methods.	8vo,	2 00
Laplace's Philosophical Essay on Probabilities. (Truscott and Emory.)	12mo,	2 00
Mahan's Treatise on Civil Engineering. (1873.) (Wood.)	8vo,	5 00
* Descriptive Géométry.	8vo,	1 50
Merriman's Elements of Precise Surveying and Geodesy.	8vo,	2 50
Elements of Sanitary Engineering.	8vo,	2 00
Merriman and Brooks's Handbook for Surveyors.	16mo; morocco,	2 00
Nugent's Plane Surveying.	8vo,	3 50
Ogden's Sewer Design.	12mo,	2 00
Patton's Treatise on Civil Engineering.	8vo half leather,	7 50
Reed's Topographical Drawing and Sketching	4to,	5 00
Rideal's Sewage and the Bacterial Purification of Sewage.	8vo,	3 50
Siebert and Biggin's Modern Stone-cutting and Masonry.	8vo,	1 50
Smith's Manual of Topographical Drawing. (McMillan.)	8vo,	2 50
Sondericker's Graphic Statics, with Applications to Trusses, Beams, and Arches.	8vo,	2 00
Taylor and Thompson's Treatise on Concrete, Plain and Reinforced.	8vo,	5 00
* Trautwine's Civil Engineer's Pocket-book.	16mo, morocco,	5 00
Wait's Engineering and Architectural Jurisprudence.	8vo,	6 00
Sheep,	6 50	
Law of Operations Preliminary to Construction in Engineering and Architecture.	8vo,	5 00
Sheep,	5 50	
Law of Contracts.	8vo,	3 00
Warren's Stereotomy—Problems in Stone-cutting.	8vo,	2 50
Webb's Problems in the Use and Adjustment of Engineering Instruments.	16mo, morocco,	1 25
* Wheeler's Elementary Course of Civil Engineering.	8vo,	4 00
Wilson's Topographic Surveying.	8vo,	3 50

BRIDGES AND ROOFS.

Boller's Practical Treatise on the Construction of Iron Highway Bridges.	8vo,	2 00
* Thames River Bridge.	4to, paper,	5 00
Burr's Course on the Stresses in Bridges and Roof Trusses, Arched Ribs, and Suspension Bridges.	8vo,	3 50
Burr and Falk's Influence Lines for Bridge and Roof Computations.	8vo,	3 00
Du Bois's Mechanics of Engineering. Vol. II.	Small 4to,	10 00
Foster's Treatise on Wooden Trestle Bridges.	4to,	5 00
Fowler's Ordinary Foundations.	8vo,	3 50
Greene's Roof Trusses.	8vo,	1 25
Bridge Trusses.	8vo,	2 50
Arches in Wood, Iron, and Stone.	8vo,	2 50
Howe's Treatise on Arches.	8vo,	4 00
Design of Simple Roof-trusses in Wood and Steel.	8vo,	2 00
Johnson, Bryan, and Turneure's Theory and Practice in the Designing of Modern Framed Structures.	Small 4to,	10 00
Merriman and Jacoby's Text-book on Roofs and Bridges:		
Part I. Stresses in Simple Trusses.	8vo,	2 50
Part II. Graphic Statics.	8vo,	2 50
Part III. Bridge Design.	8vo,	2 50
Part IV. Higher Structures.	8vo,	2 50
Morison's Memphis Bridge.	4to,	10 00
Waddell's De Pontibus, a Pocket-book for Bridge Engineers.	16mo, morocco,	3 00
Specifications for Steel Bridges.	12mo,	1 25
Wood's Treatise on the Theory of the Construction of Bridges and Roofs.	8vo,	2 00
Wright's Designing of Draw-spans:		
Part I. Plate-girder Draws.	8vo,	2 50
Part II. Riveted-truss and Pin-connected Long-span Draws.	8vo,	2 50
Two parts in one volume.	8vo,	3 50

HYDRAULICS.

Bazin's Experiments upon the Contraction of the Liquid Vein Issuing from an Orifice. (Trautwine.)	8vo,	2 00
Bovey's Treatise on Hydraulics.	8vo,	5 00
Church's Mechanics of Engineering.	8vo,	6 00
Diagrams of Mean Velocity of Water in Open Channels.	paper,	1 50
Coffin's Graphical Solution of Hydraulic Problems.	16mo, morocco,	2 50
Flather's Dynamometers, and the Measurement of Power.	12mo,	3 00
Folwell's Water-supply Engineering.	8vo,	4 00
Frizell's Water-power.	8vo,	5 00
Fuertes's Water and Public Health.	12mo,	1 50
Water-filtration Works.	12mo,	2 50
Ganguillet and Kutter's General Formula for the Uniform Flow of Water in Rivers and Other Channels. (Hering and Trautwine.)	8vo,	4 00
Hazen's Filtration of Public Water-supply.	8vo,	3 00
Hazlehurst's Towers and Tanks for Water-works.	8vo,	2 50
Herschel's 115 Experiments on the Carrying Capacity of Large, Riveted, Metal Conduits.	8vo,	2 00
Mason's Water-supply. (Considered Principally from a Sanitary Standpoint.)	8vo,	4 00
Merriman's Treatise on Hydraulics.	8vo,	5 00
* Michie's Elements of Analytical Mechanics.	8vo,	4 00
Schuyler's Reservoirs for Irrigation, Water-power, and Domestic Water-supply.	Large 8vo,	5 00
** Thomas and Watt's Improvement of Rivers. (Post., 44c. additional.)	4to,	6 00
Turneure and Russell's Public Water-supplies.	8vo,	5 00
Wegmann's Design and Construction of Dams.	4to,	5 00
Water-supply of the City of New York from 1658 to 1895.	4to,	10 00
Williams and Hazen's Hydraulic Tables.	8vo,	1 50
Wilson's Irrigation Engineering.	Small 8vo,	4 00
Wolff's Windmill as a Prime Mover.	8vo,	3 00
Wood's Turbines.	8vo,	2 50
Elements of Analytical Mechanics.	8vo,	3 00

MATERIALS OF ENGINEERING.

Baker's Treatise on Masonry Construction.	8vo,	5 00
Roads and Pavements.	8vo,	5 00
Black's United States Public Works	Oblong 4to,	5 00
Bovey's Strength of Materials and Theory of Structures.	8vo,	7 50
Burr's Elasticity and Resistance of the Materials of Engineering.	8vo,	7 50
Byrne's Highway Construction.	8vo,	5 00
Inspection of the Materials and Workmanship Employed in Construction.	16mo,	3 00
Church's Mechanics of Engineering.	8vo,	6 00
Du Bois's Mechanics of Engineering. Vol. I.	Small 4to,	7 50
*Eckel's Cements, Limes, and Plasters.	8vo,	6 00
Johnson's Materials of Construction.	Large 8vo,	6 00
Fowler's Ordinary Foundations.	8vo,	3 50
Keep's Cast Iron.	8vo,	2 50
Lanza's Applied Mechanics.	8vo,	7 50
Marten's Handbook on Testing Materials. (Henning.) 2 vols.	8vo,	7 50
Merrill's Stones for Building and Decoration.	8vo,	5 00
Merriman's Mechanics of Materials.	8vo,	5 00
Strength of Materials	12mo,	1 00
Metcalf's Steel. A Manual for Steel-users.	12mo,	2 00
Patton's Practical Treatise on Foundations.	8vo,	5 00
Richardson's Modern Asphalt Pavements.	8vo,	3 00
Richey's Handbook for Superintendents of Construction.	16mo, mor.,	4 00
Rockwell's Roads and Pavements in France.	12mo,	1 25

Sabin's Industrial and Artistic Technology of Paints and Varnish.....	8vo,	3 00
Smith's Materials of Machines.....	12mo,	1 00
Snow's Principal Species of Wood.....	8vo,	3 50
Spalding's Hydraulic Cement.....	12mo,	2 00
Text-book on Roads and Pavements.....	12mo,	2 00
Taylor and Thompson's Treatise on Concrete, Plain and Reinforced.....	8vo,	5 00
Thurston's Materials of Engineering. 3 Parts.....	8vo,	8 00
Part I. Non-metallic Materials of Engineering and Metallurgy.....	8vo,	2 00
Part II. Iron and Steel.....	8vo,	3 50
Part III. A Treatise on Brasses, Bronzes, and Other Alloys and their Constituents.....	8vo,	2 50
Thurston's Text-book of the Materials of Construction.....	8vo,	5 00
Tillson's Street Pavements and Paving Materials.....	8vo,	4 00
Waddell's De Pontibus. ([^] Pocket-book for Bridge Engineers.).....	16mo, mor.,	3 00
Specifications for Steel Bridges.....	12mo,	1 25
Wood's (De V.) Treatise on the Resistance of Materials, and an Appendix on the Preservation of Timber.....	8vo,	2 00
Wood's (De V.) Elements of Analytical Mechanics.....	8vo,	3 00
Wood's (M. P.) Rustless Coatings: Corrosion and Electrolysis of Iron and Steel.....	8vo,	4 00

RAILWAY ENGINEERING.

Andrew's Handbook for Street Railway Engineers.....	3x5 inches, morocco,	1 25
Berg's Buildings and Structures of American Railroads.....	4to,	5 00
Brook's Handbook of Street Railroad Location.....	16mo, morocco,	1 50
Butt's Civil Engineer's Field-book.....	16mo, morocco,	2 50
Crandall's Transition Curve.....	16mo, morocco,	1 50
Railway and Other Earthwork Tables.....	8vo,	1 50
Dawson's "Engineering" and Electric Traction Pocket-book.....	16mo, morocco,	5 00
Dredge's History of the Pennsylvania Railroad: (1879).....	Paper,	5 00
* Drinker's Tunnelling, Explosive Compounds, and Rock Drills.....	4to, half mor.,	25 00
Fisher's Table of Cubic Yards.....	Cardboard,	25
Godwin's Railroad Engineers' Field-book and Explorers' Guide.....	16mo, mor.,	2 50
Howard's Transition Curve Field-book.....	16mo, morocco,	1 50
Hudson's Tables for Calculating the Cubic Contents of Excavations and Em- bankments.....	8vo,	1 00
Molitor and Beard's Manual for Resident Engineers.....	16mo,	1 00
Nagle's Field Manual for Railroad Engineers.....	16mo, morocco,	3 00
Philbrick's Field Manual for Engineers.....	16mo, morocco,	3 00
Searles's Field Engineering.....	16mo, morocco,	3 00
Railroad Spiral.....	16mo, morocco,	1 50
Taylor's Prismatical Formulæ and Earthwork.....	8vo,	1 50
* Trautwine's Method of Calculating the Cube Contents of Excavations and Embankments by the Aid of Diagrams.....	8vo,	2 00
The Field Practice of Laying Out Circular Curves for Railroads.....	12mo, morocco,	2 50
Cross-section Sheet.....	Paper,	25
Webb's Railroad Construction.....	16mo, morocco,	5 00
Wellington's Economic Theory of the Location of Railways.....	Small 8vo,	5 00

DRAWING.

Barr's Kinematics of Machinery.....	8vo,	2 50
* Bartlett's Mechanical Drawing.....	8vo,	3 00
* " " " " Abridged Ed.....	8vo,	1 50
Coolidge's Manual of Drawing.....	8vo, paper	1 00
Coolidge and Freeman's Elements of General Drafting for Mechanical Engi- neers.....	Oblong 4to,	2 50
Durley's Kinematics of Machines.....	8vo,	4 00
Emch's Introduction to Projective Geometry and its Applications.....	8vo.	2 50

Hill's Text-book on Shades and Shadows, and Perspective.	8vo,	2 00
Jamison's Elements of Mechanical Drawing.	8vo,	2 50
Advanced Mechanical Drawing.	8vo,	2 00
Jones's Machine Design:		
Part I. Kinematics of Machinery.	8vo,	1 50
Part II. Form, Strength, and Proportions of Parts.	8vo,	3 00
MacCord's Elements of Descriptive Geometry.	8vo,	3 00
Kinematics; or, Practical Mechanism.	8vo,	5 00
Mechanical Drawing.	4to,	4 00
Velocity Diagrams.	8vo,	1 50
* Mahan's Descriptive Geometry and Stone-cutting.	8vo,	1 50
Industrial Drawing. (Thompson.)	8vo,	3 50
Moyer's Descriptive Geometry.	8vo,	2 00
Reed's Topographical Drawing and Sketching.	4to,	5 00
Reid's Course in Mechanical Drawing.	8vo,	2 00
Text-book of Mechanical Drawing and Elementary Machine Design.	8vo,	3 00
Robinson's Principles of Mechanism.	8vo,	3 00
Schwamb and Merrill's Elements of Mechanism.	8vo,	3 00
Smith's Manual of Topographical Drawing. (McMillan.)	8vo,	2 50
Warren's Elements of Plane and Solid Free-hand Geometrical Drawing.	12mo,	1 00
Drafting Instruments and Operations.	12mo,	1 25
Manual of Elementary Projection Drawing.	12mo,	1 50
Manual of Elementary Problems in the Linear Perspective of Form and Shadow.	12mo,	1 00
Plane Problems in Elementary Geometry	12mo,	1 25
Primary Geometry.	12mo,	75
Elements of Descriptive Geometry, Shades, and Perspective.	8vo,	3 50
General Problems of Shades and Shadows.	8vo,	3 00
Elements of Machine Construction and Drawing.	8vo,	7 50
Problems, Theorems, and Examples in Descriptive Geometry.	8vo,	2 50
Weisbach's Kinematics and Power of Transmission. (Hermann and Klein)	8vo,	5 00
Whelpley's Practical Instruction in the Art of Letter Engraving.	12mo,	2 00
Wilson's (H. M.) Topographic Surveying.	8vo,	3 50
Wilson's (V. T.) Free-hand Perspective.	8vo,	2 50
Wilson's (V. T.) Free-hand Lettering.	8vo,	1 00
Woolf's Elementary Course in Descriptive Geometry.	Large 8vo,	3 00

ELECTRICITY AND PHYSICS.

Anthony and Brackett's Text-book of Physics. (Magie.)	Small 8vo,	3 00
Anthony's Lecture-notes on the Theory of Electrical Measurements.	12mo,	1 00
Benjamin's History of Electricity.	8vo,	3 00
Voltaic Cell.	8vo,	3 00
Classen's Quantitative Chemical Analysis by Electrolysis. (Boltwood.)	8vo,	3 00
Crehore and Squier's Polarizing Photo-chronograph.	8vo,	3 00
Dawson's "Engineering" and Electric Traction Pocket-book.	16mo, morocco,	5 00
Dolezalek's Theory of the Lead Accumulator (Storage Battery). (Von Ende.)	12mo,	2 50
Duhem's Thermodynamics and Chemistry. (Burgess.)	8vo,	4 00
Flather's Dynamometers, and the Measurement of Power.	12mo,	3 00
Gilbert's De Magnete. (Mottelay.)	8vo,	2 50
Hanchett's Alternating Currents Explained.	12mo,	1 00
Hering's Ready Reference Tables (Conversion Factors).	16mo, morocco,	2 50
Holman's Precision of Measurements.	8vo,	2 00
Telescopic Mirror-scale Method, Adjustments, and Tests.	Large 8vo,	75
Kinzbrunner's Testing of Continuous-Current Machines.	8vo,	2 00
Landauer's Spectrum Analysis. (Tingle.)	8vo,	3 00
Le Chatelien's High-temperature Measurements. (Boudouard—Burgess.)	12mo,	3 00
Löb's Electrolysis and Electrosynthesis of Organic Compounds. (Lorenz.)	12mo,	1 00

* Lyons's Treatise on Electromagnetic Phenomena. Vols. I. and II. 8vo, each	6 00
* Michie's Elements of Wave Motion Relating to Sound and Light. 8vo,	4 00
Niaudet's Elementary Treatise on Electric Batteries. (Fishback.) 12mo,	2 50
* Rosenberg's Electrical Engineering. (Haldane Gee—Kinzbrunner.) . . 8vo,	1 50
Ryan, Norris, and Hoxie's Electrical Machinery. Vol. I. 8vo,	2 50
Thurston's Stationary Steam-engines. 8vo,	2 50
* Tillman's Elementary Lessons in Heat. 8vo,	1 50
Tory and Pitcher's Manual of Laboratory Physics. Small 8vo,	2 00
Ulke's Modern Electrolytic Copper Refining. 8vo,	3 00

LAW.

* Davis's Elements of Law. 8vo,	2 50
* Treatise on the Military Law of United States. 8vo,	7 00
* Sheep,	7 50
Manual for Courts-martial. 16mo, morocco,	1 50
Wait's Engineering and Architectural Jurisprudence. 8vo,	6 00
Sheep,	6 50
Law of Operations Preliminary to Construction in Engineering and Archi- tecture. 8vo,	5 00
Sheep,	5 50
Law of Contracts. 8vo,	3 00
Winthrop's Abridgment of Military Law. 12mo,	2 50

MANUFACTURES.

Bernadou's Smokeless Powder—Nitro-cellulose and Theory of the Cellulose Molecule. 12mo,	2 50
Bolland's Iron Founder. 12mo,	2 50
"The Iron Founder," Supplement. 12mo,	2 50
Encyclopedia of Founding and Dictionary of Foundry Terms Used in the Practice of Moulding. 12mo,	3 00
Eissler's Modern High Explosives. 8vo,	4 00
Effront's Enzymes and their Applications. (Prescott.) 8vo,	3 00
Fitzgerald's Boston Machinist. 12mo,	1 00
Ford's Boiler Making for Boiler Makers. 18mo,	1 00
Hopkin's Oil-chemists' Handbook. 8vo,	3 00
Keep's Cast Iron. 8vo,	2 50
Leach's The Inspection and Analysis of Food with Special Reference to State Control. Large 8vo,	7 50
Matthews's The Textile Fibres. 8vo,	3 50
Metcalfe's Steel. A Manual for Steel-users. 12mo,	2 00
Metcalfe's Cost of Manufactures—And the Administration of Workshops. 8vo,	5 00
Meyer's Modern Locomotive Construction. 4to,	10 00
Morse's Calculations used in Cane-sugar Factories. 16mo, morocco,	1 50
* Reisig's Guide to Piece-dyeing. 8vo,	25 00
Sabin's Industrial and Artistic Technology of Paints and Varnish. 8vo,	3 00
Smith's Press-working of Metals. 8vo,	3 00
Spalding's Hydraulic Cement. 12mo,	2 00
Spencer's Handbook for Chemists of Beet-sugar Houses. 16mo, morocco,	3 00
Handbook for Sugar Manufacturers and their Chemists. 16mo, morocco,	2 00
Taylor and Thompson's Treatise on Concrete, Plain and Reinforced. . . . 8vo,	5 00
Thurston's Manual of Steam-boilers, their Designs, Construction and Opera- tion. 8vo,	5 00
* Walke's Lectures on Explosives. 8vo,	4 00
Ware's Manufacture of Sugar. (In press.)	
West's American Foundry Practice. 12mo,	2 50
Moulder's Text-book. 12mo,	2 50

Cromwell's Treatise on Toothed Gearing	12mo,	1 50
Treatise on Belts and Pulleys.	12mo,	1 50
Durley's Kinematics of Machines.	8vo,	4 00
Flather's Dynamometers and the Measurement of Power.	12mo,	3 00
Rope Driving.	12mo,	2 00
Gill's Gas and Fuel Analysis for Engineers.	12mo,	1 25
Hall's Car Lubrication.	12mo,	1 00
Hering's Ready Reference Tables (Conversion Factors).	16mo, morocco,	2 50
Hutton's The Gas Engine.	8vo,	5 00
Jamison's Mechanical Drawing.	8vo,	2 50
Jones's Machine Design:		
Part I. Kinematics of Machinery.	8vo,	1 50
Part II. Form, Strength, and Proportions of Parts.	8vo,	3 00
Kent's Mechanical Engineers' Pocket-book.	16mo, morocco,	5 00
Kerr's Power and Power Transmission.	8vo,	2 00
Leonard's Machine Shop, Tools, and Methods.	8vo,	4 00
*Lorenz's Modern Refrigerating Machinery. (Pope, Haven, and Dean.)	8vo,	4 00
MacCord's Kinematics; or, Practical Mechanism.	8vo,	5 00
Mechanical Drawing.	4to,	4 00
Velocity Diagrams.	8vo,	1 50
Mahan's Industrial Drawing. (Thompson.)	8vo,	3 50
Poole's Calorific Power of Fuels.	8vo,	3 00
Reid's Course in Mechanical Drawing.	8vo,	2 00
Text-book of Mechanical Drawing and Elementary Machine Design.	8vo,	3 00
Richard's Compressed Air	12mo,	1 50
Robinson's Principles of Mechanism.	8vo,	3 00
Schwamb and Merrill's Elements of Mechanism.	8vo,	3 00
Smith's Press-working of Metals.	8vo,	3 00
Thurston's Treatise on Friction and Lost Work in Machinery and Mill Work.	8vo,	3 00
Animal as a Machine and Prime Motor, and the Laws of Energetics.	12mo,	1 00
Warren's Elements of Machine Construction and Drawing.	8vo,	7 50
Weisbach's Kinematics and the Power of Transmission. (Herrmann— Klein.)	8vo,	5 00
Machinery of Transmission and Governors. (Herrmann—Klein.)	8vo,	5 00
Wolff's Windmill as a Prime Mover.	8vo,	3 00
Wood's Turbines.	8vo,	2 50

MATERIALS OF ENGINEERING.

Bovey's Strength of Materials and Theory of Structures.	8vo,	7 50
Burr's Elasticity and Resistance of the Materials of Engineering. 6th Edition. Reset.	8vo,	7 50
Church's Mechanics of Engineering.	8vo,	6 00
Johnson's Materials of Construction.	8vo,	6 00
Keep's Cast Iron.	8vo,	2 50
Lanza's Applied Mechanics.	8vo,	7 50
Martens's Handbook on Testing Materials. (Henning.)	8vo,	7 50
Merriman's Mechanics of Materials.	8vo,	5 00
Strength of Materials	12mo,	1 00
Metcalf's Steel. A manual for Steel-users.	12mo.	2 00
Sabin's Industrial and Artistic Technology of Paints and Varnish.	8vo,	3 00
Smith's Materials of Machines.	12mo,	1 00
Thurston's Materials of Engineering.	3 vols., 8vo,	8 00
Part II. Iron and Steel.	8vo,	3 50
Part III. A Treatise on Brasses, Bronzes, and Other Alloys and their Constituents.	8vo,	2 50
Text-book of the Materials of Construction.	8vo,	5 00

Wood's (De V.) Treatise on the Resistance of Materials and an Appendix on the Preservation of Timber.8vo,	2 00
Wood's (De V.) Elements of Analytical Mechanics.8vo,	3 00
Wood's (M. P.) Rustless Coatings: Corrosion and Electrolysis of Iron and Steel.8vo,	4 00

STEAM-ENGINES AND BOILERS.

Berry's Temperature-entropy Diagram.12mo,	1 25
Carnot's Reflections on the Motive Power of Heat. (Thurston.)12mo,	1 50
Dawson's "Engineering" and Electric Traction Pocket-book.16mo, mor.,	5 00
Ford's Boiler Making for Boiler Makers.18mo,	1 00
Goss's Locomotive Sparks.8vo,	2 00
Hemenway's Indicator Practice and Steam-engine Economy.12mo,	2 00
Hutton's Mechanical Engineering of Power Plants.8vo,	5 00
Heat and Heat-engines.8vo,	5 00
Kent's Steam boiler Economy.8vo,	4 00
Kneass's Practice and Theory of the Injector.8vo,	1 50
MacCord's Slide-valves.8vo,	2 00
Meyer's Modern Locomotive Construction.4to,	10 00
Peabody's Manual of the Steam-engine Indicator.12mo,	1 50
Tables of the Properties of Saturated Steam and Other Vapors.8vo,	1 00
Thermodynamics of the Steam-engine and Other Heat-engines.8vo,	5 00
Valve-gears for Steam-engines.8vo,	2 50
Peabody and Miller's Steam-boilers.8vo,	4 00
Pray's Twenty Years with the Indicator.	Large 8vo,	2 50
Pupin's Thermodynamics of Reversible Cycles in Gases and Saturated Vapors. (Osterberg.)12mo,	1 25
Reagan's Locomotives: Simple Compound, and Electric.12mo,	2 50
Rontgen's Principles of Thermodynamics. (Du Bois.)8vo,	5 00
Sinclair's Locomotive Engine Running and Management.12mo,	2 00
Smart's Handbook of Engineering Laboratory Practice.12mo,	2 50
Snow's Steam-boiler Practice.8vo,	3 00
Spangler's Valve-gears.8vo,	2 50
Notes on Thermodynamics.12mo,	1 00
Spangler, Greene, and Marshall's Elements of Steam-engineering8vo,	3 00
Thurston's Handy Tables.8vo,	1 50
Manual of the Steam-engine.	2 vols., 8vo,	10 00
Part I. History, Structure, and Theory.8vo,	6 00
Part II. Design, Construction, and Operation.8vo,	6 00
Handbook of Engine and Boiler Trials, and the Use of the Indicator and the Prony Brake.8vo,	5 00
Stationary Steam-engines.8vo,	2 50
Steam-boiler Explosions in Theory and in Practice12mo,	1 50
Manual of Steam-boilers, their Designs, Construction, and Operation.8vo,	5 00
Weisbach's Heat, Steam, and Steam-engines. (Du Bois.)8vo,	5 00
Whitham's Steam-engine Design.8vo,	5 00
Wilson's Treatise on Steam-boilers. (Flather.)16mo,	2 50
Wood's Thermodynamics, Heat Motors, and Refrigerating Machines.8vo,	4 00

MECHANICS AND MACHINERY.

Barr's Kinematics of Machinery.8vo,	2 50
Bovey's Strength of Materials and Theory of Structures8vo,	7 50
Chase's The Art of Pattern-making.12mo,	2 50
Church's Mechanics of Engineering.8vo,	6 00

Church's Notes and Examples in Mechanics.	8vo,	2 00
Compton's First Lessons in Metal-working.	12mo,	1 50
Compton and De Groodt's The Speed Lathe	12mo,	1 50
Cromwell's Treatise on Toothed Gearing	12mo,	1 50
Treatise on Belts and Pulleys.	12mo,	1 50
Dana's Text-book of Elementary Mechanics for Colleges and Schools.	12mo,	1 50
Dingey's Machinery Pattern Making	12mo,	2 00
Dredge's Record of the Transportation Exhibits Building of the World's Columbian Exposition of 1893.	4to half morocco,	5 00
Du Bois's Elementary Principles of Mechanics:		
Vol. I. Kinematics.	8vo,	3 50
Vol. II. Statics.	8vo,	4 00
Vol. III. Kinetics.	8vo,	3 50
Mechanics of Engineering. Vol. I.	Small 4to,	7 50
Vol. II.	Small 4to,	10 00
Durley's Kinematics of Machines.	8vo,	4 00
Fitzgerald's Boston Machinist.	16mo,	1 00
Flather's Dynamometers, and the Measurement of Power.	12mo,	3 00
Rope Driving.	12mo,	2 00
Goss's Locomotive Sparks.	8vo,	2 00
Hall's Car Lubrication.	12mo,	1 00
Holly's Art of Saw Filing.	18mo,	75
James's Kinematics of a Point and the Rational Mechanics of a Particle. Sm. 8vo.		2 00
* Johnson's (W. W.) Theoretical Mechanics.	12mo,	3 00
Johnson's (L. J.) Statics by Graphic and Algebraic Methods.	8vo,	2 00
Jones's Machine Design:		
Part I. Kinematics of Machinery.	8vo,	1 50
Part II. Form, Strength, and Proportions of Parts.	8vo,	3 00
Kerr's Power and Power Transmission.	8vo,	2 00
Lanza's Applied Mechanics.	8vo,	7 50
Leonard's Machine Shop, Tools, and Methods.	8vo,	4 00
* Lorenz's Modern Refrigerating Machinery. (Pope, Haven, and Dean.)	8vo,	4 00
MacCord's Kinematics; or, Practical Mechanism.	8vo,	5 00
Velocity Diagrams.	8vo,	1 50
Maurer's Technical Mechanics.	8vo,	4 00
Merriman's Mechanics of Materials.	8vo,	5 00
* Elements of Mechanics.	12mo,	1 00
* Michie's Elements of Analytical Mechanics.	8vo,	4 00
Reagan's Locomotives: Simple, Compound, and Electric.	12mo,	2 50
Reid's Course in Mechanical Drawing.	8vo,	2 00
Text-book of Mechanical Drawing and Elementary Machine Design.	8vo,	3 00
Richards's Compressed Air.	12mo,	1 50
Robinson's Principles of Mechanism.	8vo,	3 00
Ryan, Norris, and Hoxie's Electrical Machinery. Vol. I.	8vo,	2 50
Schwamb and Merrill's Elements of Mechanism.	8vo,	3 00
Sinclair's Locomotive-engine Running and Management.	12mo,	2 00
Smith's (O.) Press-working of Metals	8vo,	3 00
Smith's (A. W.) Materials of Machines.	12mo,	1 00
Spangler, Greene, and Marshall's Elements of Steam-engineering.	8vo,	3 00
Thurston's Treatise on Friction and Lost Work in Machinery and Mill Work.	8vo,	3 00
Animal as a Machine and Prime Motor, and the Laws of Energetics.	12mo,	1 00
Warren's Elements of Machine Construction and Drawing.	8vo,	7 50
Weisbach's Kinematics and Power of Transmission. (Herrmann—Klein.)	8vo,	5 00
Machinery of Transmission and Governors. (Herrmann—Klein.)	8vo,	5 00
Wood's Elements of Analytical Mechanics.	8vo,	3 00
Principles of Elementary Mechanics.	12mo,	1 25
Turbines.	8vo,	2 50
The World's Columbian Exposition of 1893	4to,	1 00

METALLURGY.

Egleston's Metallurgy of Silver, Gold, and Mercury:	
Vol. I. Silver.	8vo, 7 50
Vol. II. Gold and Mercury.	8vo, 7 50
** Iles's Lead-smelting. (Postage 9 cents additional).	12mo, 2 50
Keep's Cast Iron.	8vo, 2 50
Kunhardt's Practice of Ore Dressing in Europe.	8vo, 1 50
Le Chatelier's High-temperature Measurements. (Boudouard—Burgess.)	12mo, 3 00
Metcalf's Steel. A Manual for Steel-users	12mo, 2 00
Smith's Materials of Machines.	12mo, 1 00
Thurston's Materials of Engineering. In Three Parts.	8vo, 8 00
Part II. Iron and Steel.	8vo, 3 50
Part III. A Treatise on Brasses, Bronzes, and Other Alloys and their Constituents.	8vo, 2 50
Ulke's Modern Electrolytic Copper Refining.	8vo, 3 00

MINERALOGY.

Barringer's Description of Minerals of Commercial Value. Oblong, morocco.	2 50
Boyd's Resources of Southwest Virginia.	8vo, 3 00
Map of Southwest Virginia.	Pocket-book form, 2 00
Brush's Manual of Determinative Mineralogy. (Penfield.)	8vo, 4 00
Chester's Catalogue of Minerals.	8vo, paper, 1 00
Cloth,	1 25
Dictionary of the Names of Minerals.	8vo, 3 50
Dana's System of Mineralogy.	Large 8vo, half leather, 12 50
First Appendix to Dana's New "System of Mineralogy."	Large 8vo, 1 00
Text-book of Mineralogy.	8vo, 4 00
Minerals and How to Study Them	12mo, 1 50
Catalogue of American Localities of Minerals.	Large 8vo, 1 00
Manual of Mineralogy and Petrography.	12mo, 2 00
Douglas's Untechnical Addresses on Technical Subjects.	12mo, 1 00
Eakle's Mineral Tables.	8vo, 1 25
Egleston's Catalogue of Minerals and Synonyms.	8vo, 2 50
Hussak's The Determination of Rock-forming Minerals. (Smith.) Small 8vo.	2 00
Merrill's Non-metallic Minerals: Their Occurrence and Uses.	8vo, 4 00
* Penfield's Notes on Determinative Mineralogy and Record of Mineral Tests. 8vo paper,	0 50
Rosenbusch's Microscopical Physiography of the Rock-making Minerals. (Iddings.)	8vo, 5 00
* Tillman's Text-book of Important Minerals and Rocks.	8vo, 2 00
Williams's Manual of Lithology.	8vo, 3 00

MINING.

Beard's Ventilation of Mines.	12mo, 2 50
Boyd's Resources of Southwest Virginia.	8vo, 3 00
Map of Southwest Virginia.	Pocket book form, 2 00
Douglas's Untechnical Addresses on Technical Subjects	12mo, 1 00
* Drinker's Tunneling, Explosive Compounds, and Rock Drills. .4to, hf. mor.	25 00
Eissler's Modern High Explosives.	8vo, 4 00
Fowler's Sewage Works Analyses.	12mo, 2 00
Goodyear's Coal-mines of the Western Coast of the United States.	12mo, 2 50
Ihlseng's Manual of Mining.	8vo, 5 00
** Iles's Lead-smelting. (Postage 9c. additional).	12mo, 2 50
Kunhardt's Practice of Ore Dressing in Europe.	8vo, 1 50
O'Driscoll's Notes on the Treatment of Gold Ores.	8vo, 2 00
* Walke's Lectures on Explosives.	8vo, 4 00
Wilson's Cyanide Processes.	12mo, 1 50
Chlorination Process.	12mo, 1 50

Wilson's Hydraulic and Placer Mining.	12mo,	2 00
Treatise on Practical and Theoretical Mine Ventilation.	12mo,	1 25

SANITARY SCIENCE.

Bashore's Sanitation of a Country House.	12mo,	1 00
Folwell's Sewerage. (Designing, Construction, and Maintenance.)	8vo,	3 00
Water-supply Engineering.	8vo,	4 00
Fuertes's Water and Public Health.	12mo,	1 50
Water-filtration Works.	12mo,	2 50
Gerhard's Guide to Sanitary House-inspection	16mo,	1 00
Goodrich's Economic Disposal of Town's Refuse.	Demy 8vo,	3 50
Hazen's Filtration of Public Water-supplies.	8vo,	3 00
Leach's The Inspection and Analysis of Food with Special Reference to State Control.	8vo,	7 50
Mason's Water-supply. (Considered principally from a Sanitary Standpoint)	8vo,	4 00
Examination of Water. (Chemical and Bacteriological.)	12mo,	1 25
Merriman's Elements of Sanitary Engineering.	8vo,	2 00
Ogden's Sewer Design.	12mo,	2 00
Prescott and Winslow's Elements of Water Bacteriology, with Special Reference to Sanitary Water Analysis.	12mo,	1 25
* Price's Handbook on Sanitation.	12mo,	1 50
Richards's Cost of Food. A Study in Dietaries.	12mo,	1 00
Cost of Living as Modified by Sanitary Science.	12mo,	1 00
Richards and Woodman's Air, Water, and Food from a Sanitary Standpoint.	8vo,	2 00
* Richards and Williams's The Dietary Computer.	8vo,	1 50
Rideal's Sewage and Bacterial Purification of Sewage.	8vo,	3 50
Turneure and Russell's Public Water-supplies.	8vo,	5 00
Von Behring's Suppression of Tuberculosis. (Bolduan.)	12mo,	1 00
Whipple's Microscopy of Drinking-water.	8vo,	3 50
Woodhull's Notes on Military Hygiene.	16mo,	1 50

MISCELLANEOUS.

De Fursac's Manual of Psychiatry. (Rosanoff and Collins.)	Large 12mo,	2 50
Emmons's Geological Guide-book of the Rocky Mountain Excursion of the International Congress of Geologists.	Large 8vo,	1 50
Ferrel's Popular Treatise on the Winds.	8vo,	4 00
Haines's American Railway Management.	12mo,	2 50
Mott's Composition, Digestibility, and Nutritive Value of Food. Mounted chart,		1 25
Fallacy of the Present Theory of Sound.	16mo,	1 00
Ricketts's History of Rensselaer Polytechnic Institute, 1824-1894.	Small 8vo,	3 00
Rostoski's Serum Diagnosis. (Bolduan.)	12mo,	1 00
Rotherham's Emphasized New Testament.	Large 8vo,	2 00
Steel's Treatise on the Diseases of the Dog.	8vo,	3 50
Totten's Important Question in Metrology.	8vo,	2 50
The World's Columbian Exposition of 1893	4to,	1 00
Von Behring's Suppression of Tuberculosis. (Bolduan.)	12mo,	1 00
Winslow's Elements of Applied Microscopy.	12mo,	1 50
Worcester and Atkinson. Small Hospitals, Establishment and Maintenance; Suggestions for Hospital Architecture: Plans for Small Hospital.	12mo,	1 25

HEBREW AND CHALDEE TEXT-BOOKS.

Green's Elementary Hebrew Grammar.	12mo,	1 25
Hebrew Chrestomathy.	8vo,	2 00
Gesenius's Hebrew and Chaldee Lexicon to the Old Testament Scriptures. (Tregelles.)	Small 4to, half morocco,	5 00
Letteris's Hebrew Bible.	8vo,	2 25

NOV 2 1005

LIBRARY OF CONGRESS



0 021 225 278 5